



## Kia Niro II (type: SG2)

01/'22-



- ✓ HYBRID
- ✓ PLUG-IN HYBRID

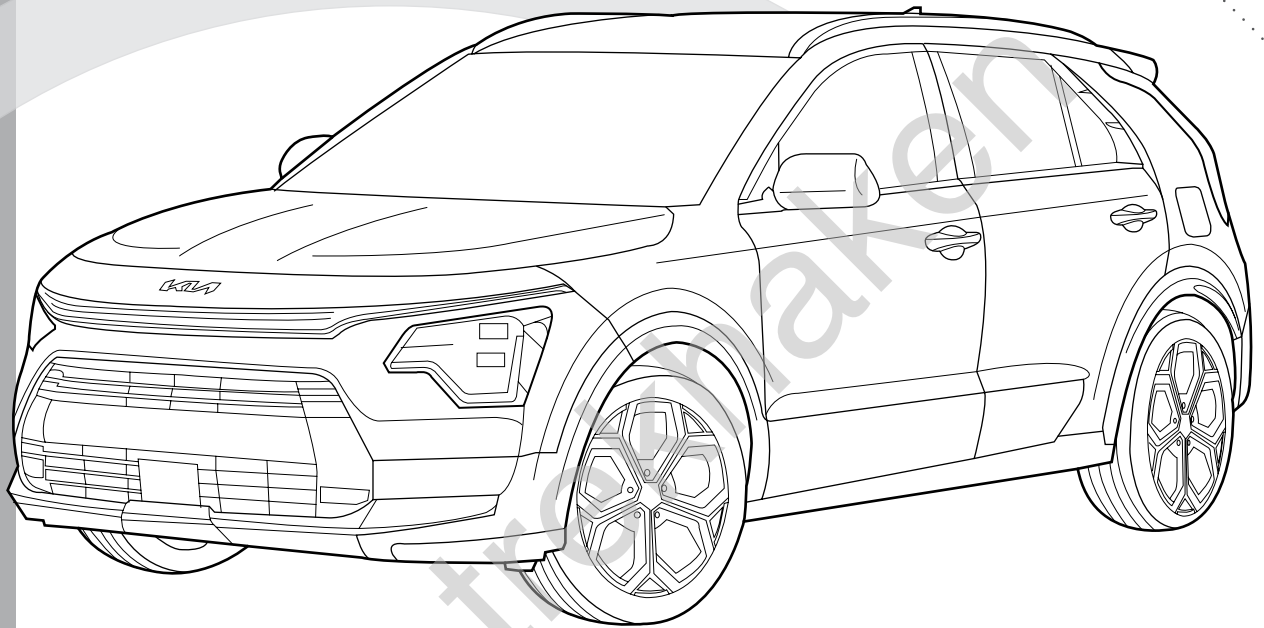

## Kia Niro II EV (type: SG2)

05/'22-

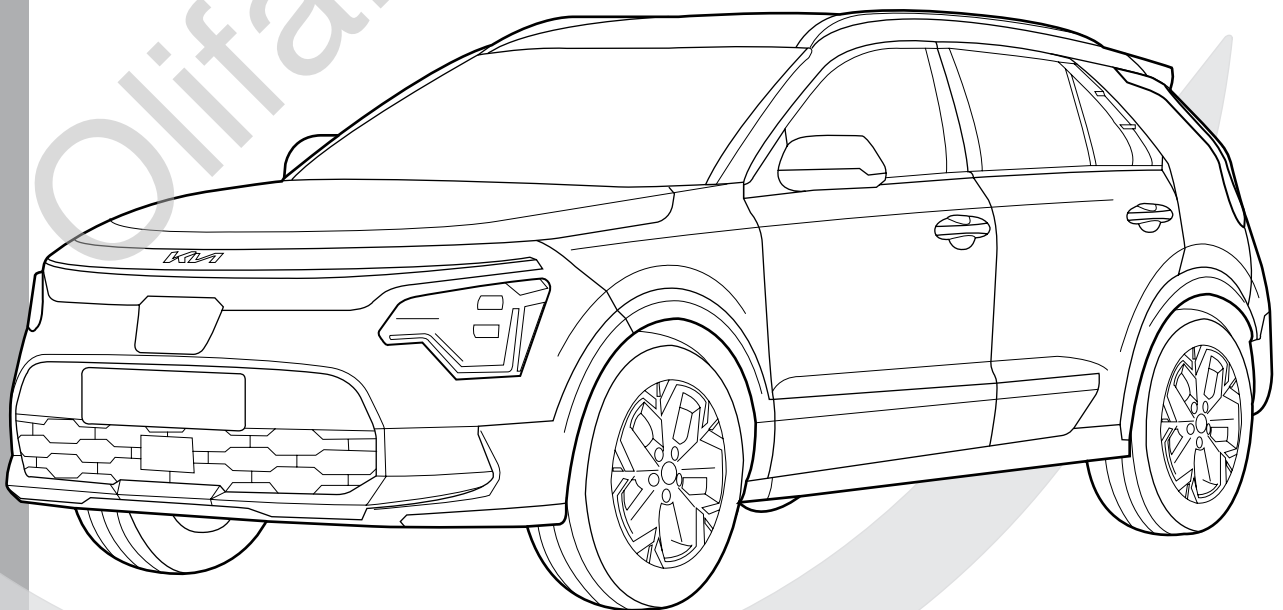

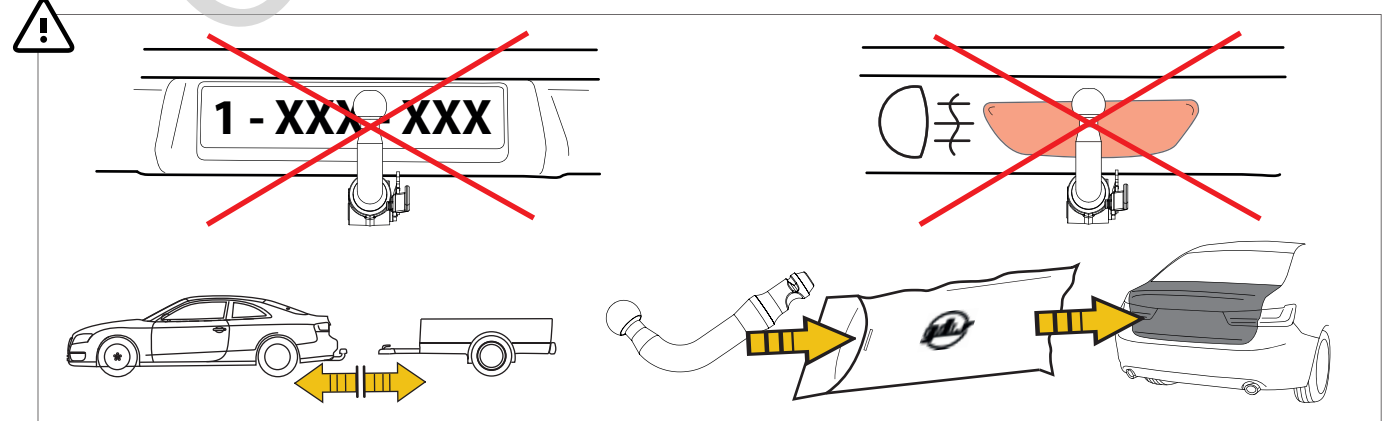
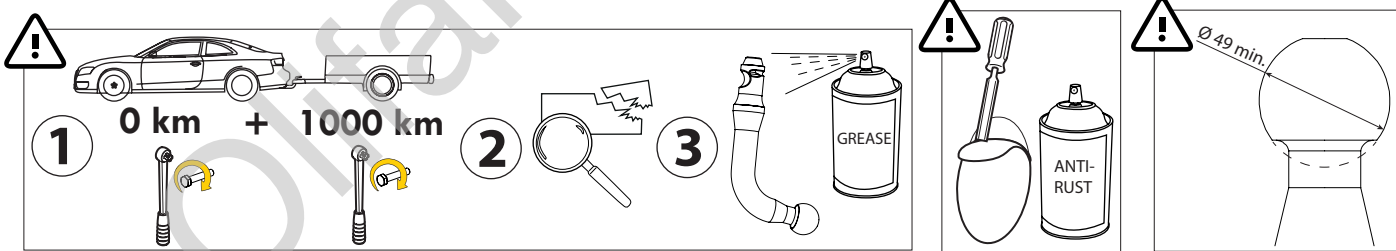
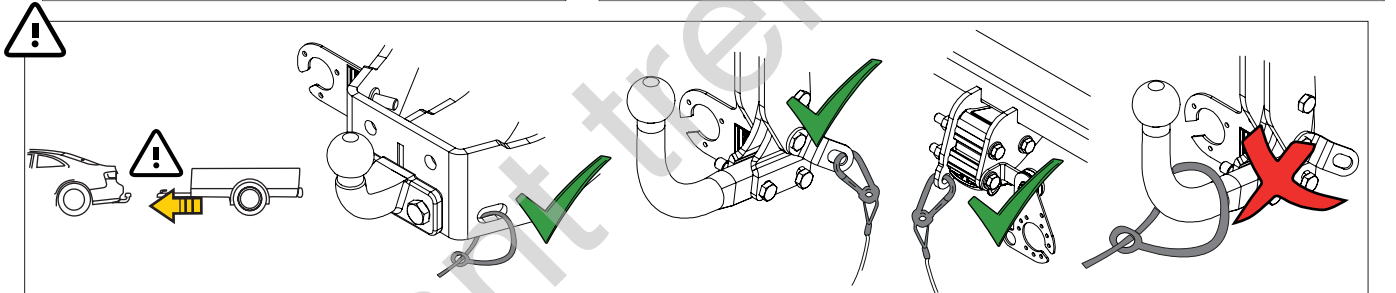
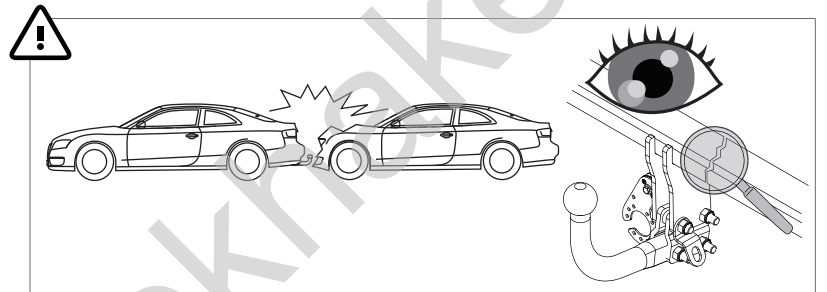
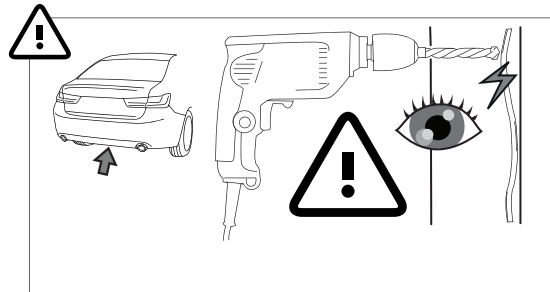
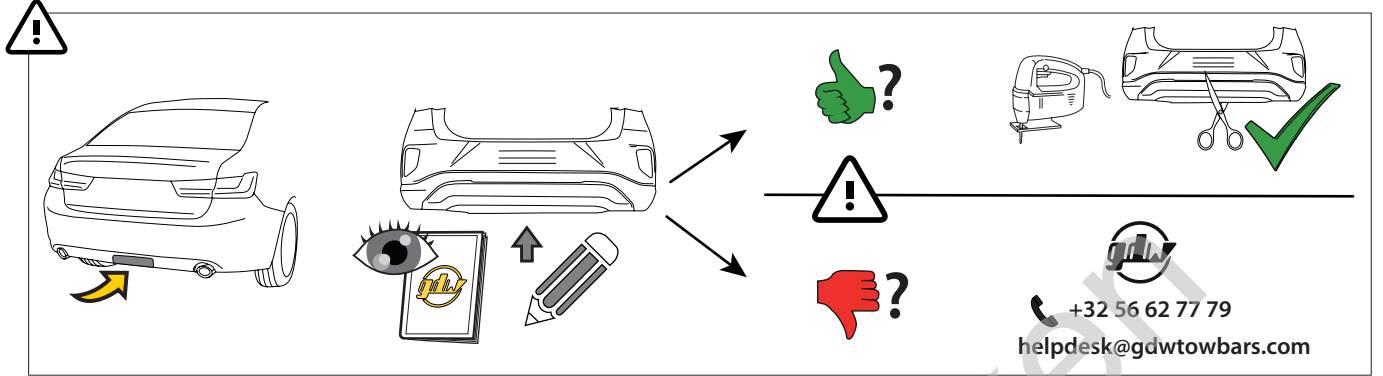
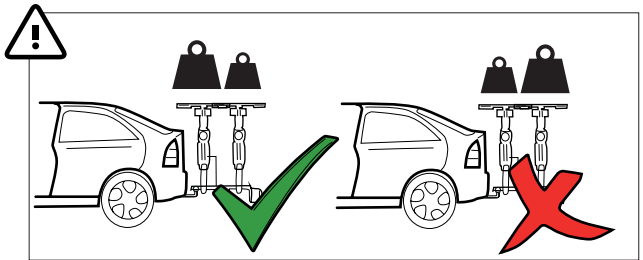
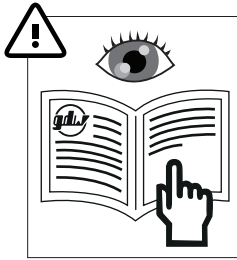
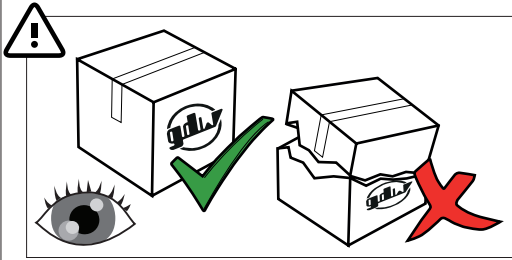



MADE BY  **D 8,20** **F** **E6**



BELGIUM **S 100** EC-N° 55R-02 1764



REF N° 2715T60 SERIAL N° XXXX

**DESCRIPTION**  
Kia Niro II

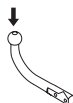

$$D = \frac{\text{max kg (car)} \times \text{max kg (trailer)}}{\text{max kg (car)} + \text{max kg (trailer)}} \times 0.00981 \leq 8,20 \text{ kN}$$

S =  ≤ 100 kg  ≤ 1350 kg

 See the Certificate Of Conformity (COC) of your vehicle or contact your dealer to verify the max. trailer weight of your car!



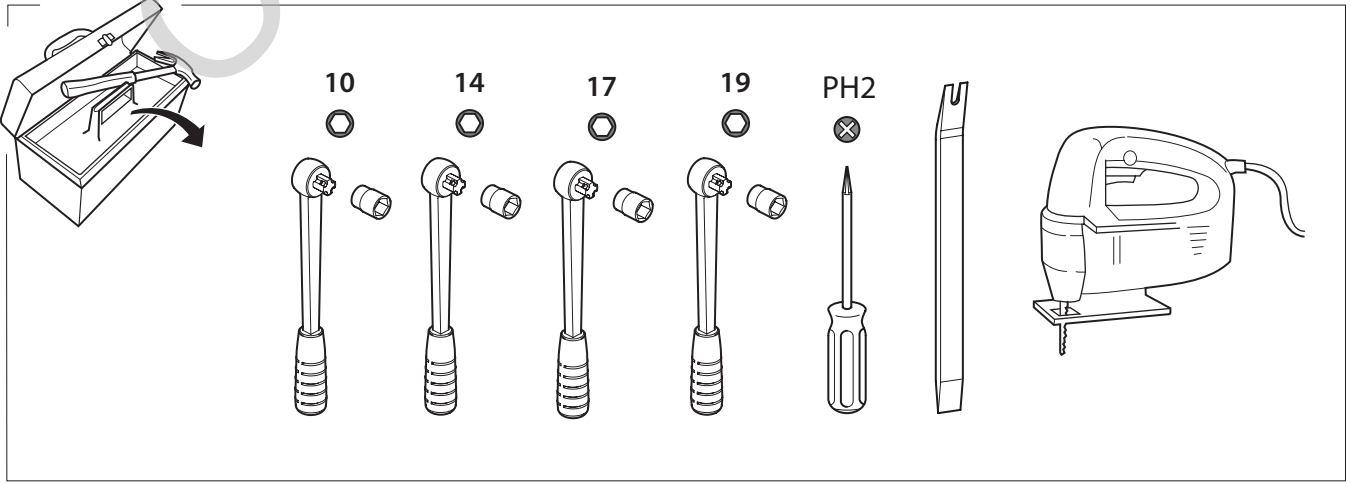
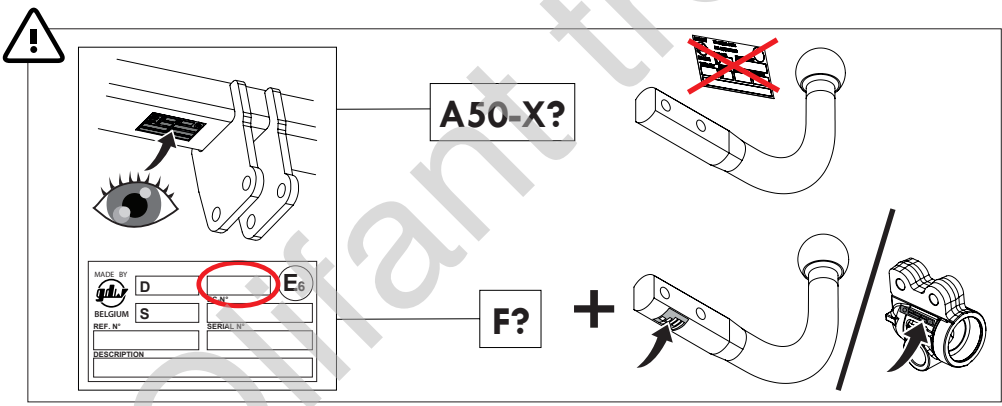
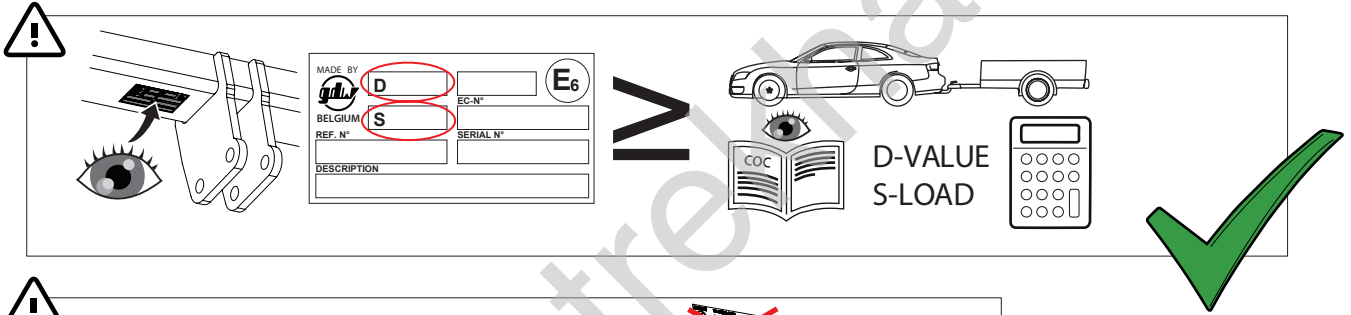
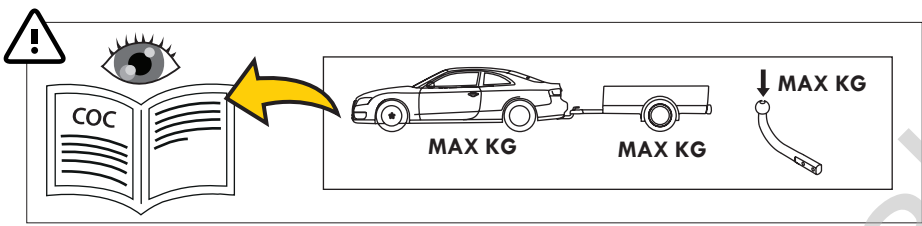

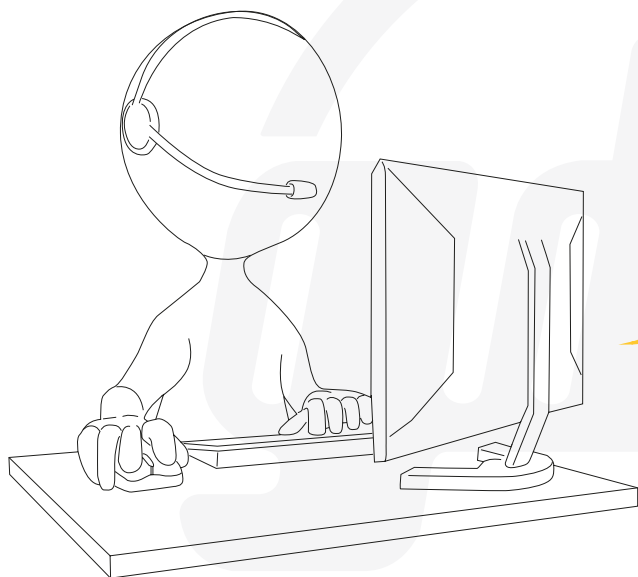





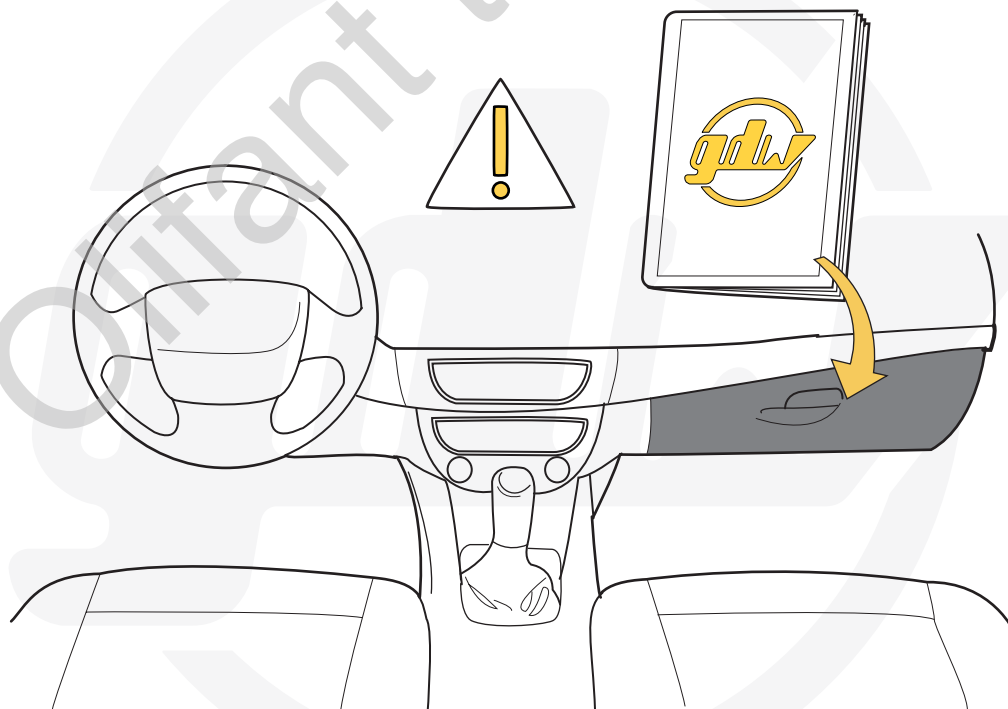

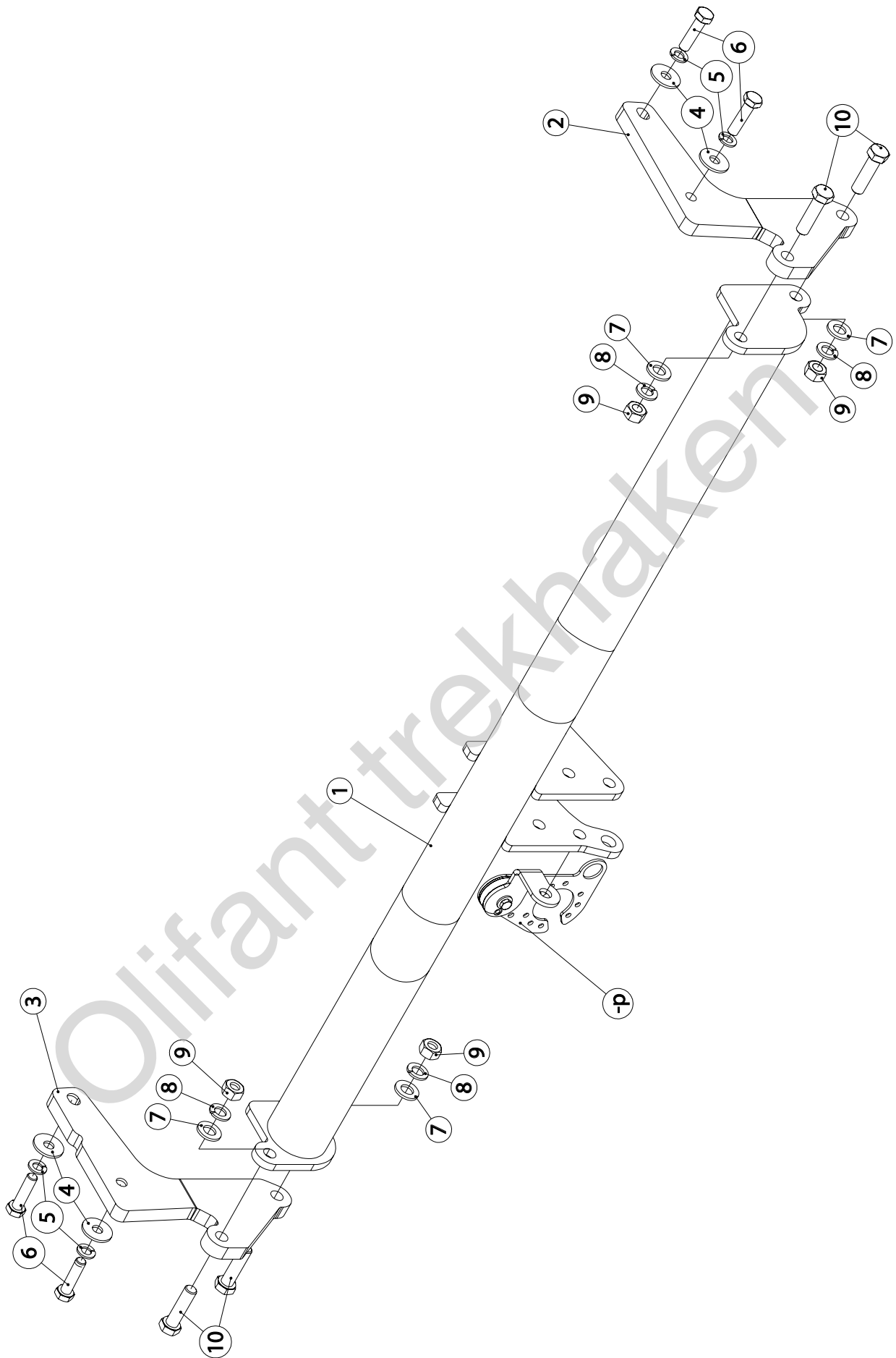
**helpdesk@gdwtowbars.com**

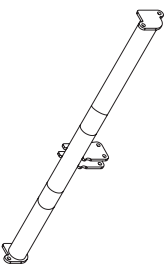
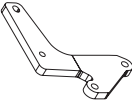
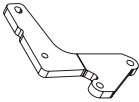







**+32 56 62 77 79**

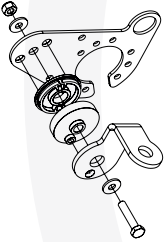

|           |               |               |
|-----------|---------------|---------------|
| Monday    | 08:00 - 12:00 | 12:30 - 16:30 |
| Tuesday   | 08:00 - 12:00 | 12:30 - 16:30 |
| Wednesday | 08:00 - 12:00 | 12:30 - 16:30 |
| Thursday  | 08:00 - 12:00 | 12:30 - 16:30 |
| Friday    | 08:00 - 12:00 | 12:30 - 15:30 |



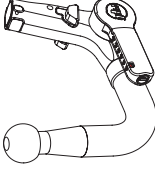
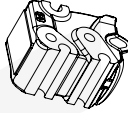
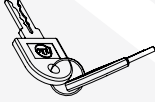

|    |   |    |                       |
|----|---|----|-----------------------|
| 1  |    | X1 | GDW REF. 2700         |
| 2  |    | X2 | GDW REF. 2            |
| 3  |    | X1 | GDW REF. 3            |
| 4  |    | X4 | DIN9021-M10-ELV       |
| 5  |    | X4 | DIN128A-M10           |
| 6  |    | X4 | DIN961-M10X35-1.25    |
| 7  |    | X4 | DIN125-A12-140HV-ELVZ |
| 8  |    | X4 | DIN128A-M12           |
| 9  |   | X4 | DIN934-M12            |
| 10 |  | X1 | DIN933-M12X45         |

|    |   |    |                          |
|----|---|----|--------------------------|
| -P |  | X1 | GDW REF. P39             |
| ↑  |  | X1 | DIN985-M6                |
| ↑  |  | X2 | 6,2 X 15,4 X 1,6 (NYLON) |
| ↑  |  | X1 | GDW REF. 718.16.002      |
| ↑  |  | X1 | GDW REF. 718.16.003      |
| ↑  |  | X1 | GDW REF. 908.094         |
| ↑  |  | X1 | DIN933-M6 X 30           |
| ↑  |  | X1 | GDW REF. 908.095         |

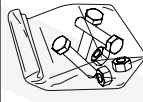
|   |   |    |  |
|---|---|----|--|
| Geleverd met - Livré avec - Delivered with<br>Geliefert mit - Elementos adjuntos-Levers med |    | X1 | GDW REF. 960.V0610                           |
|   | ↑   | X1 | GDW REF. 740.200                             |
|   |    | X1 | GDW REF. 912.003                             |
|   | ↑   | X1 | GDW REF. 740.112                             |
|   | ↑   | X1 | GDW REF. 740.111                             |
|   |    | X1 | GDW REF. 740.12X<br>X= LAST NUMBER ON<br>KEY |
|   |   | X1 | GDW REF. 718.15.001                          |
|   |  | X1 | GDW REF. SYST60-10                           |
|   | ↑   | X3 | DIN931-M12X110-8.8                           |
|   | ↑   | X3 | DIN128A-M12                                  |
|   | ↑   | X6 | DIN125A-M12                                  |
|   | ↑   | X3 | DIN934-M12                                   |

1

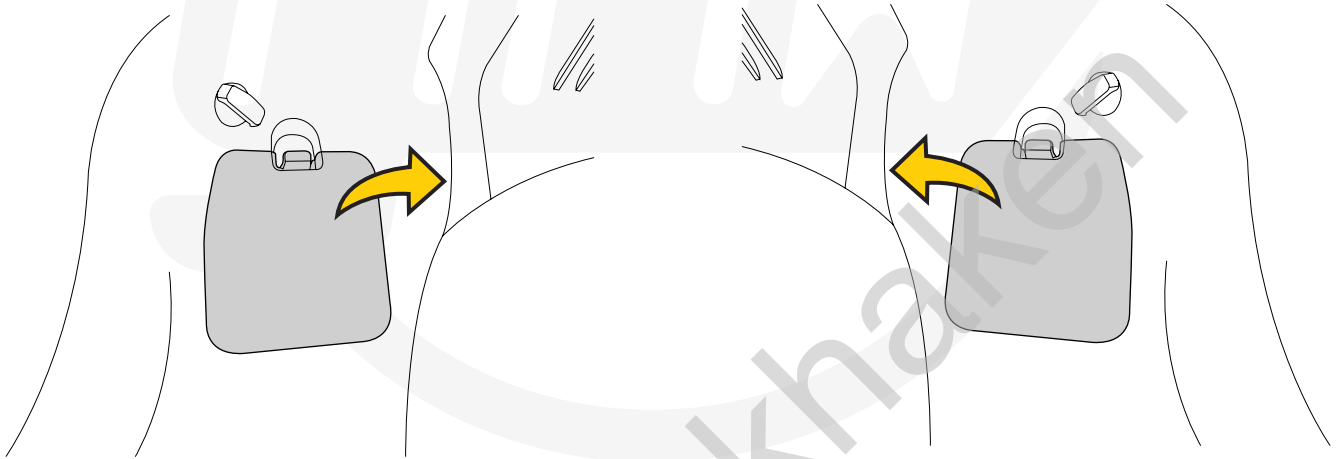
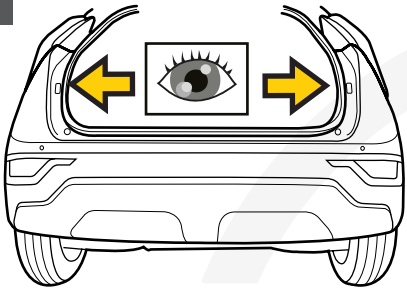

2

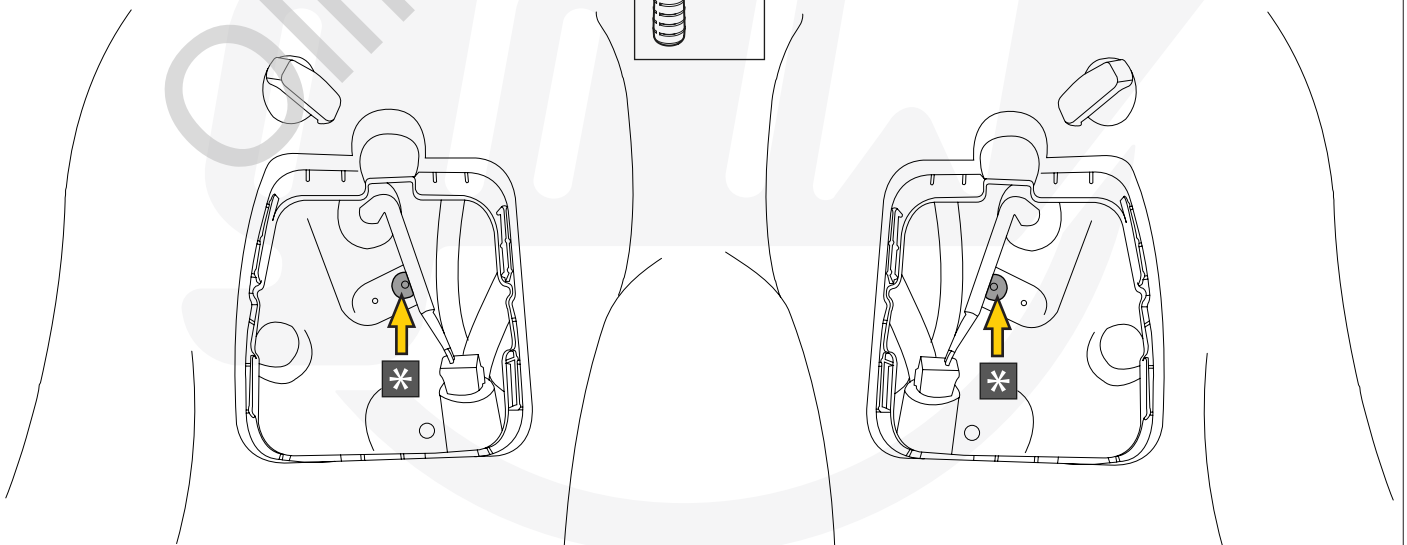
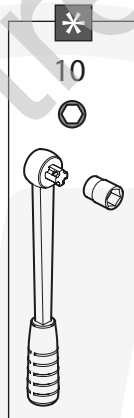
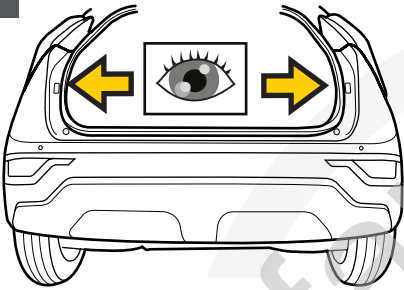

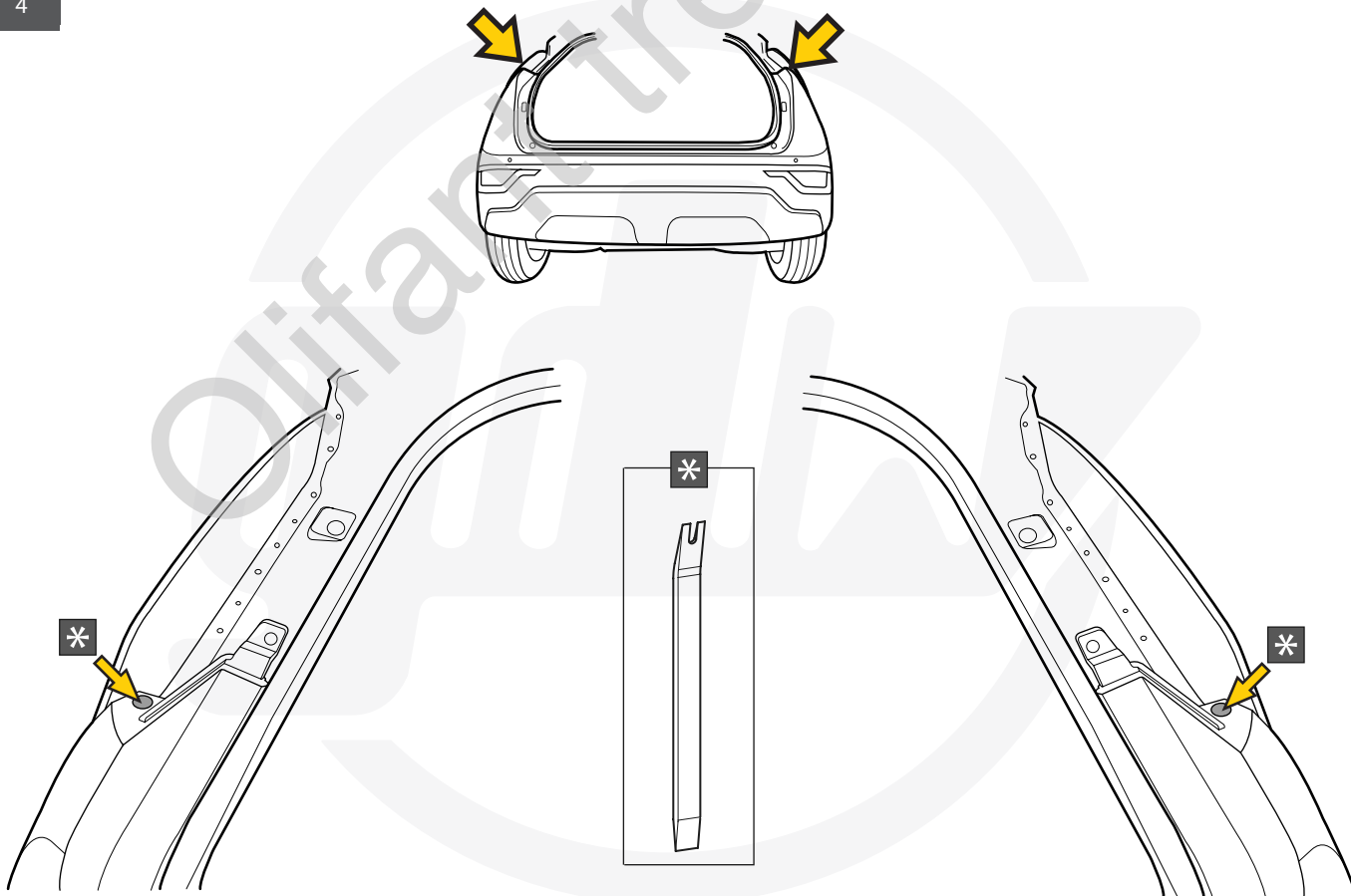
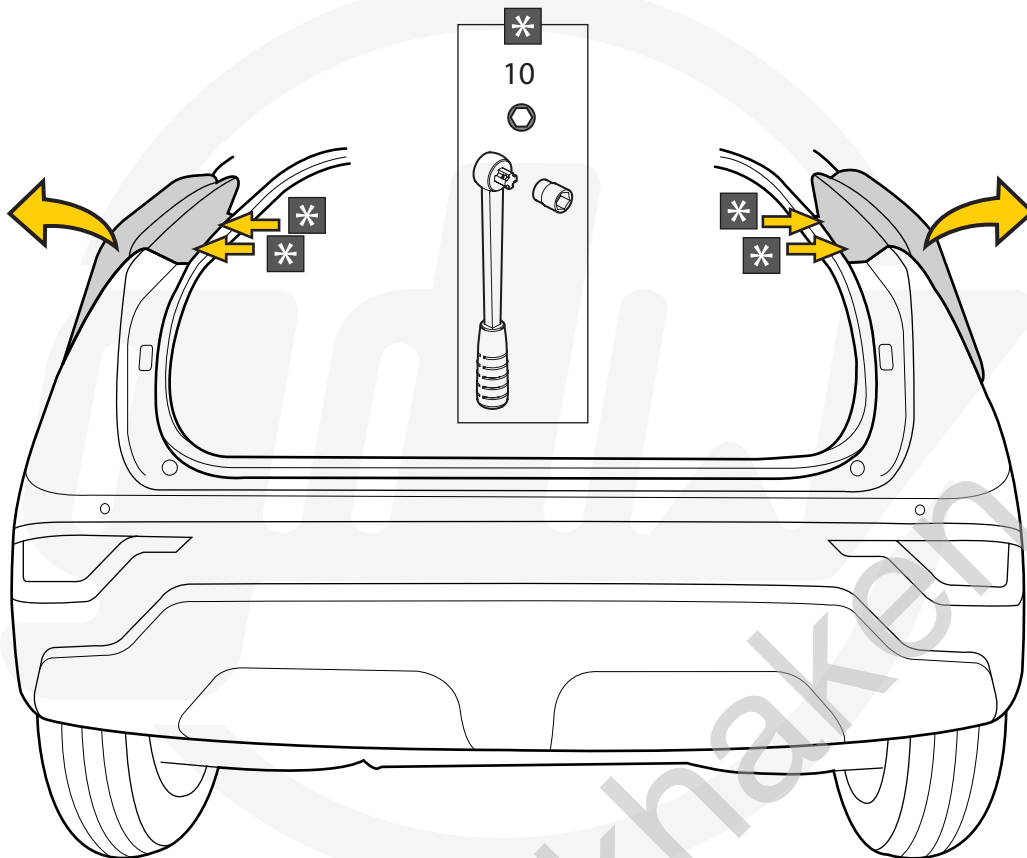



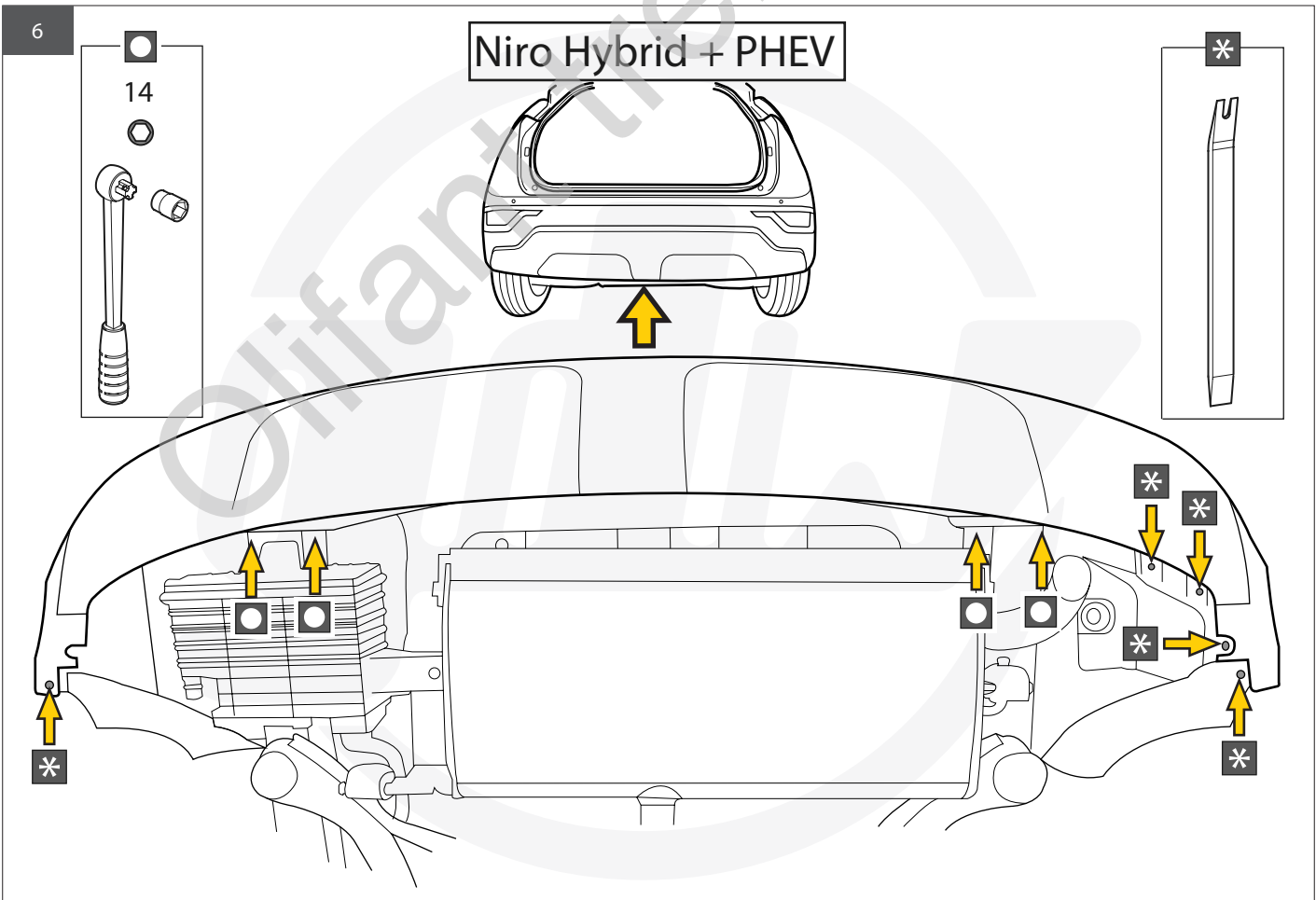
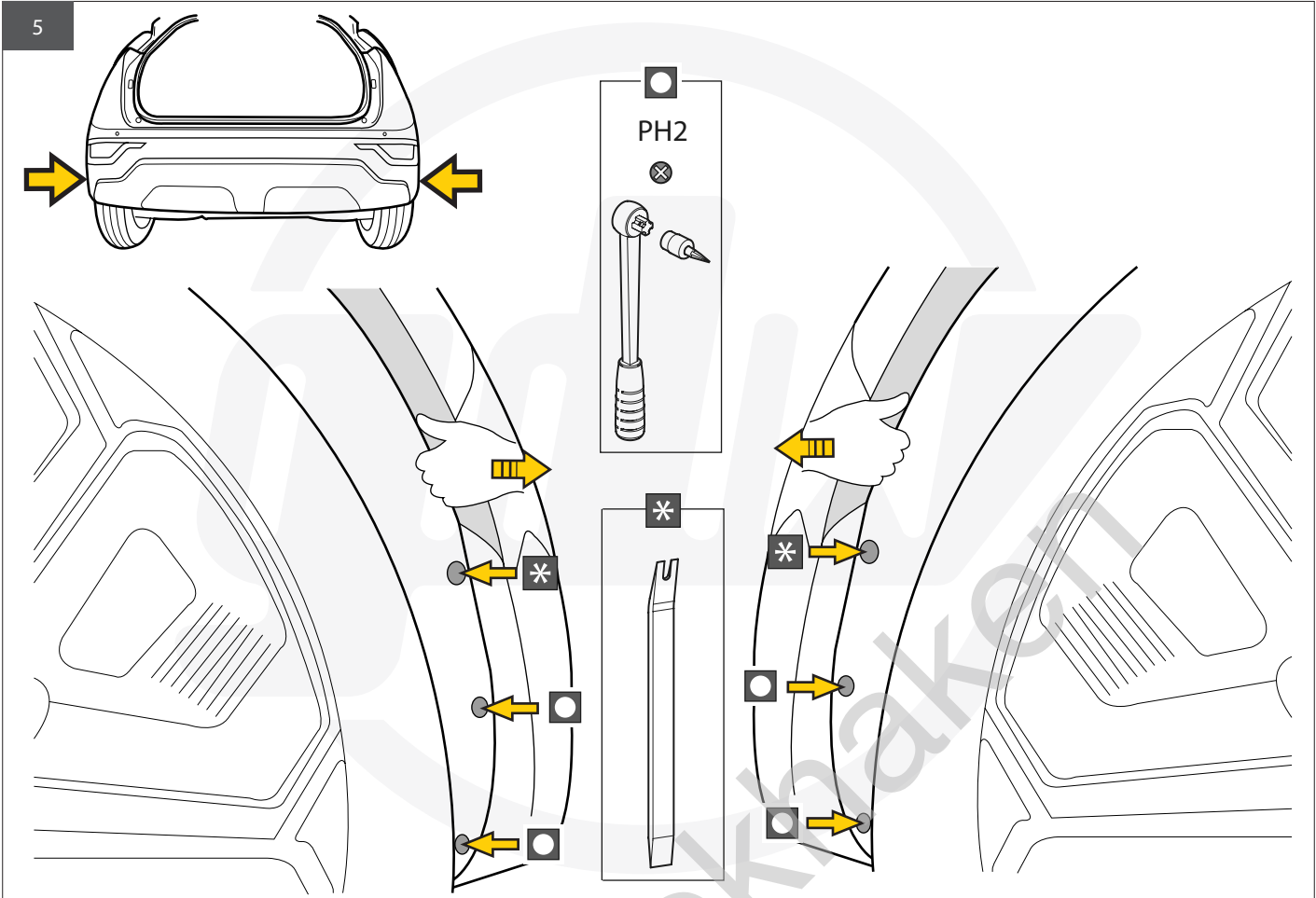

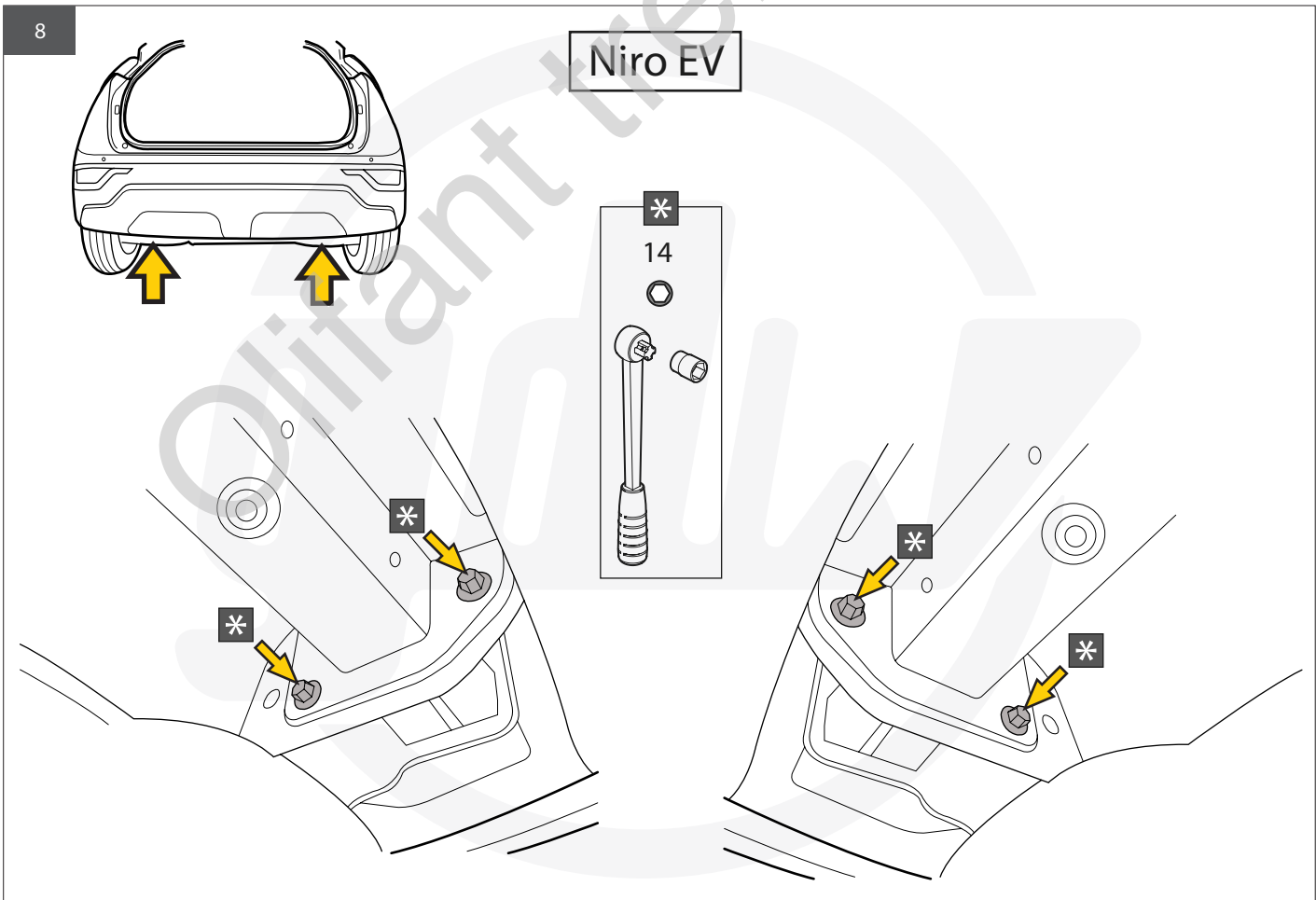
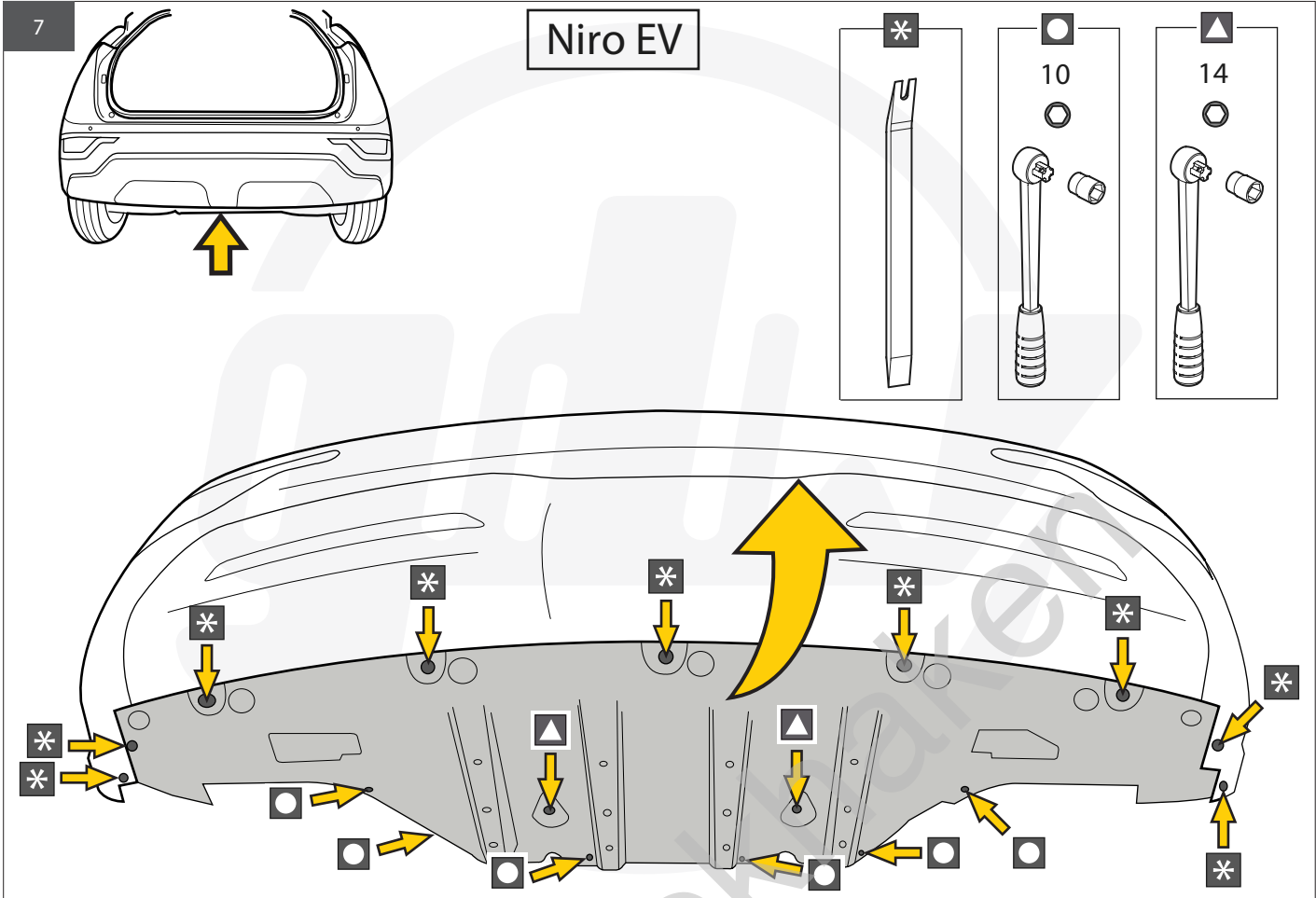

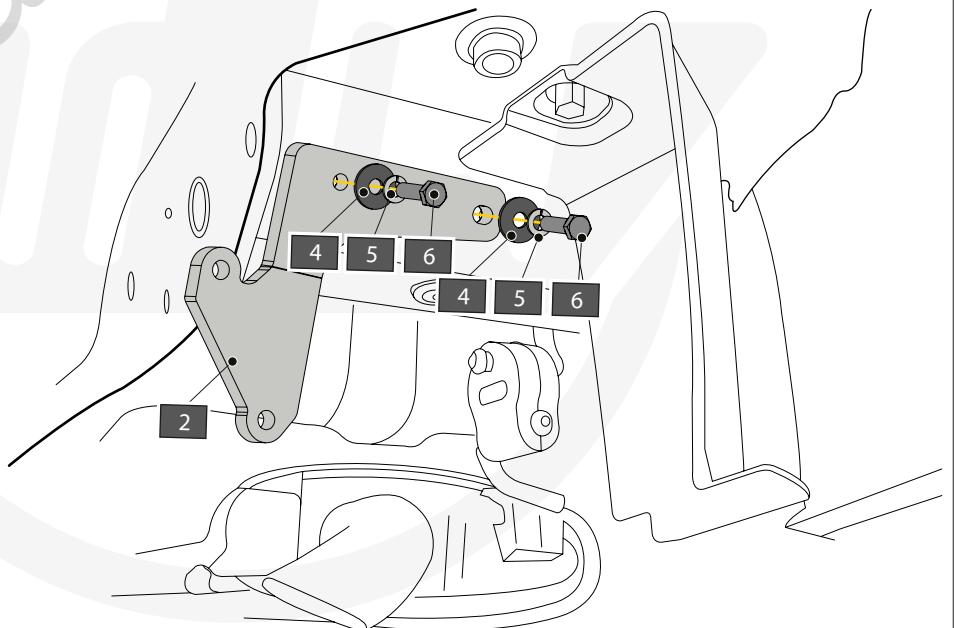
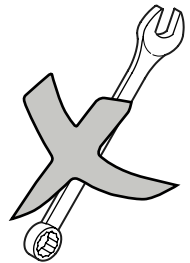
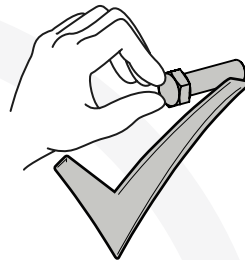
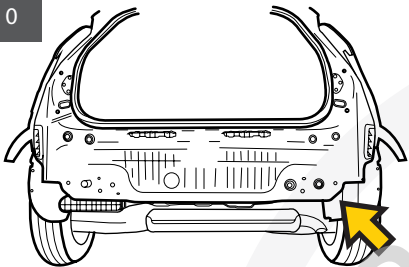
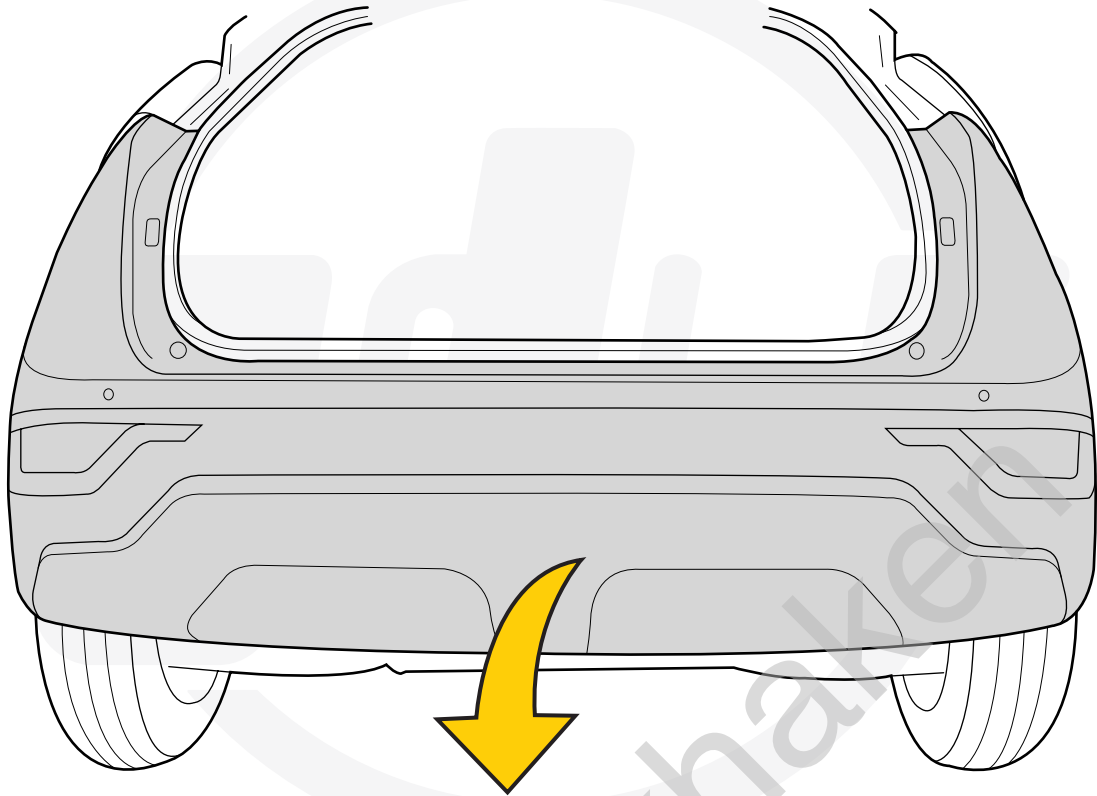

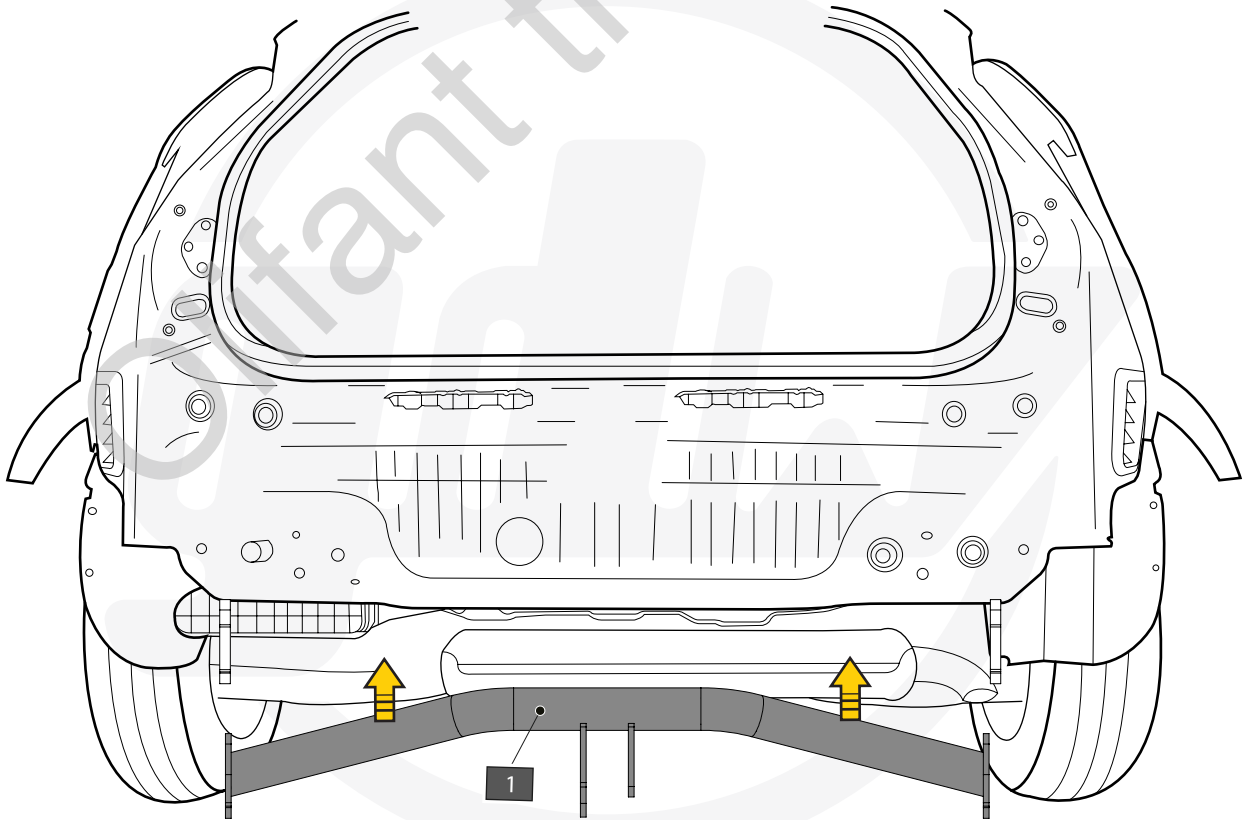
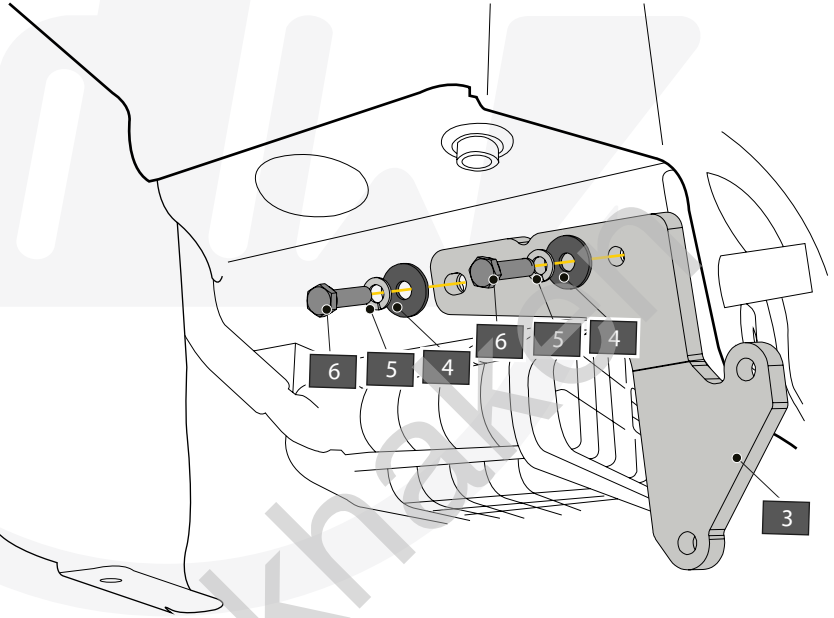
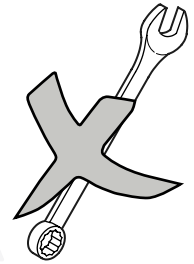
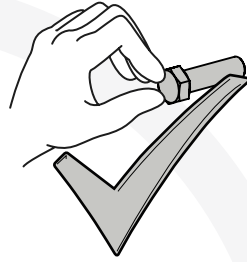
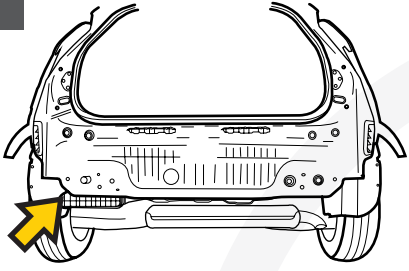

13

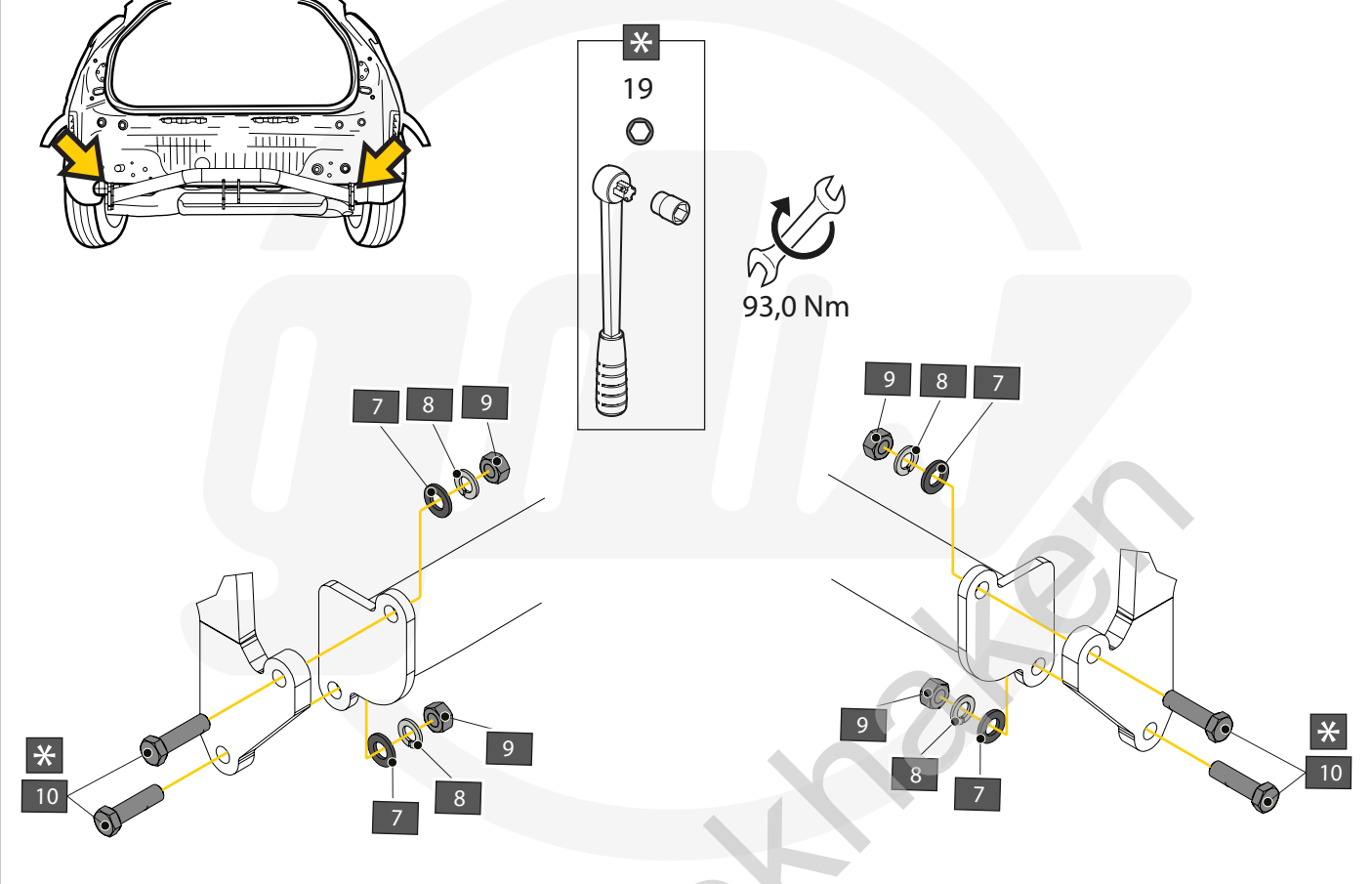

14

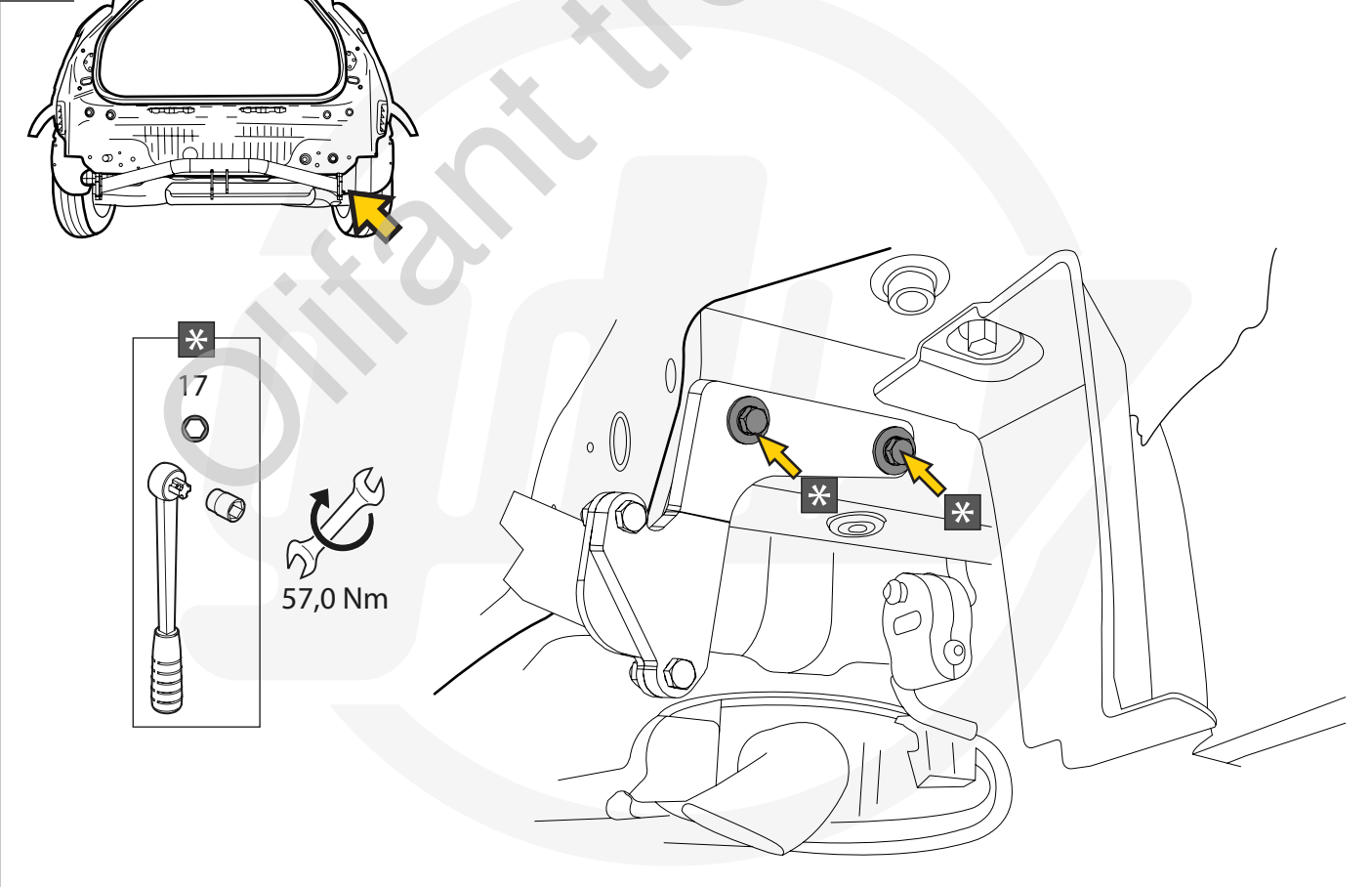

15

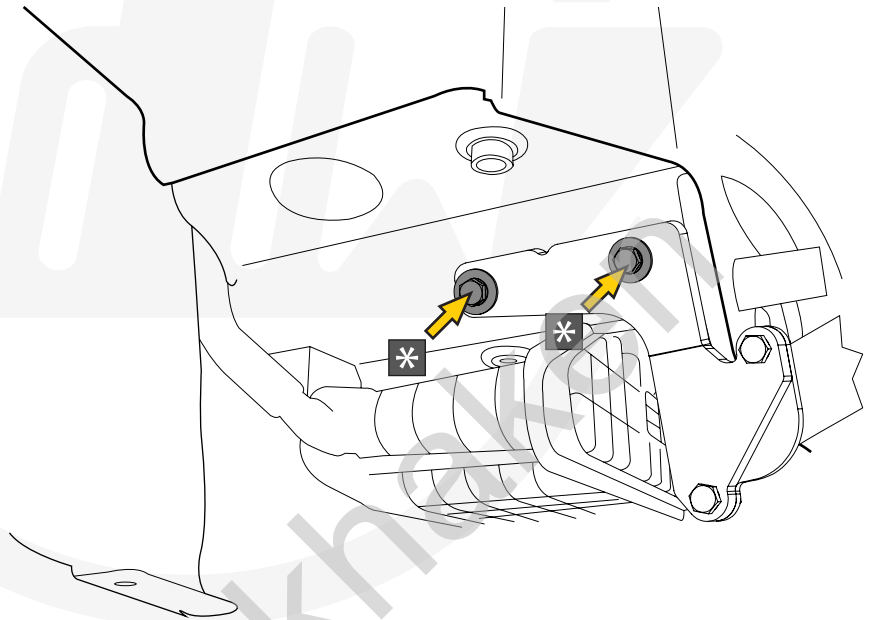
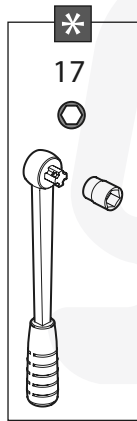
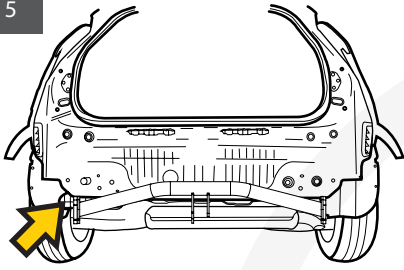

16

|   |  |    |                          |
|---|--|----|--------------------------|
| A |  | X1 | GDW REF. 908.095         |
| B |  | X1 | DIN935-M6                |
| C |  | X2 | 6,2 X 15,4 X 1,6 (NYLON) |
| D |  | X1 | GDW REF. 718.16.002      |
| E |  | X1 | GDW REF. 718.16.003      |
| F |  | X1 | GDW REF. 908.094         |
| G |  | X1 | DIN933-M6 X 30           |

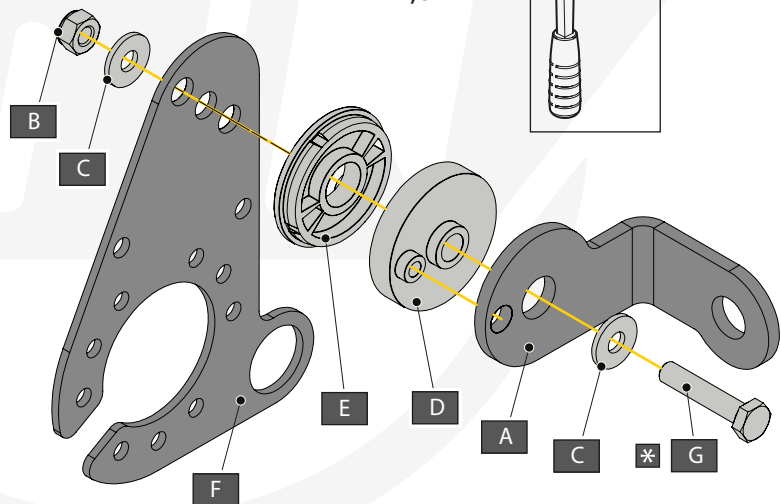
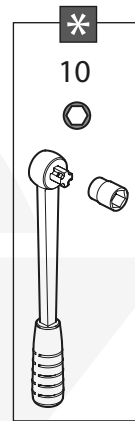

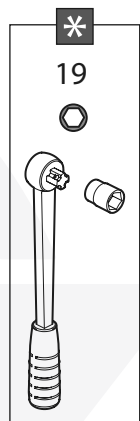
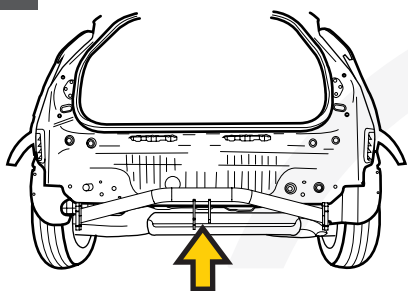

93,0 Nm

A X1 GDW REF. 912.003

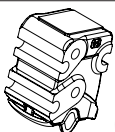

B X3 DIN931-M12X110-8.8



C X3 DIN128A-M12



D X6 DIN125A-M12



E X3 DIN934-M12

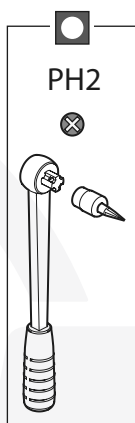
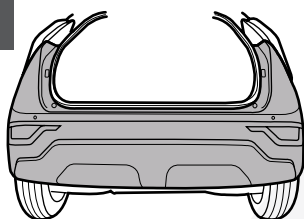
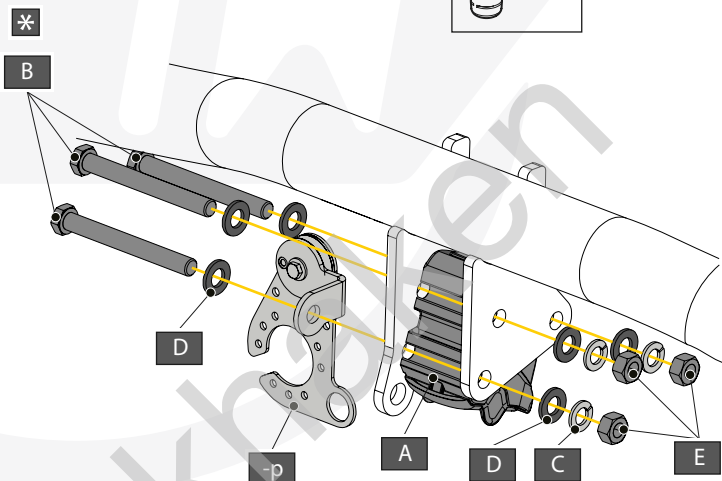

PH2

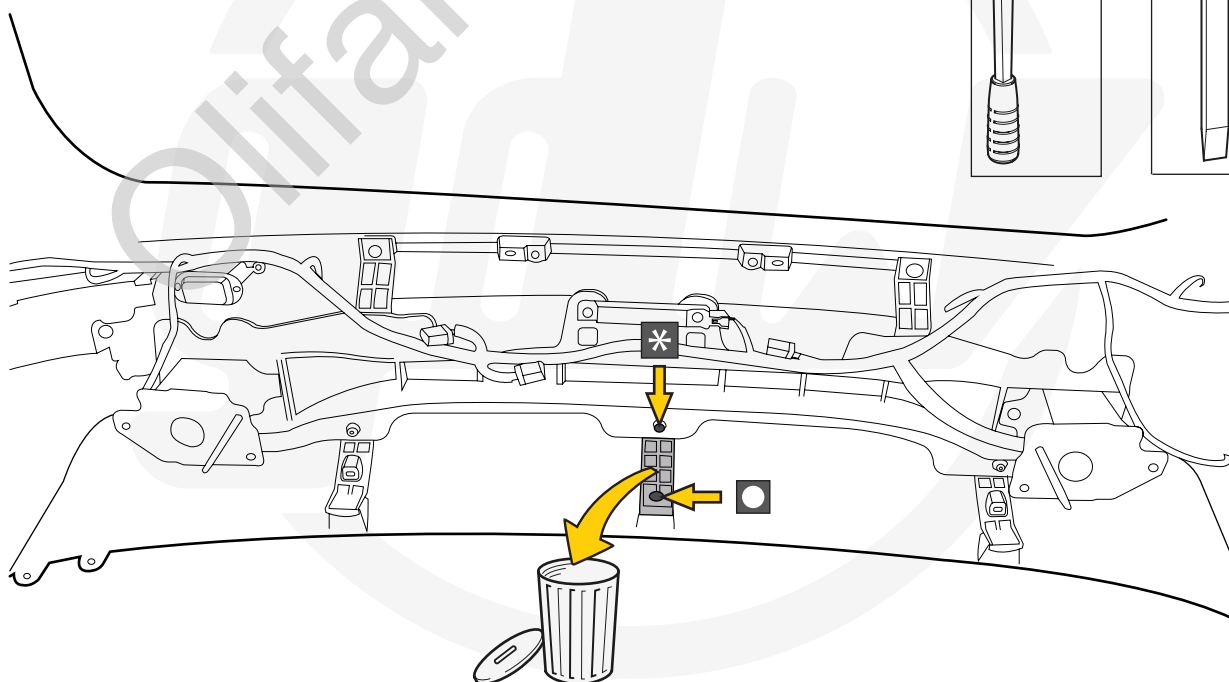
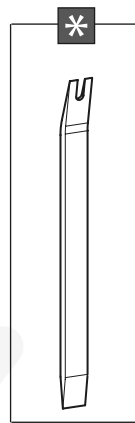

### Niro Hybrid + PHEV

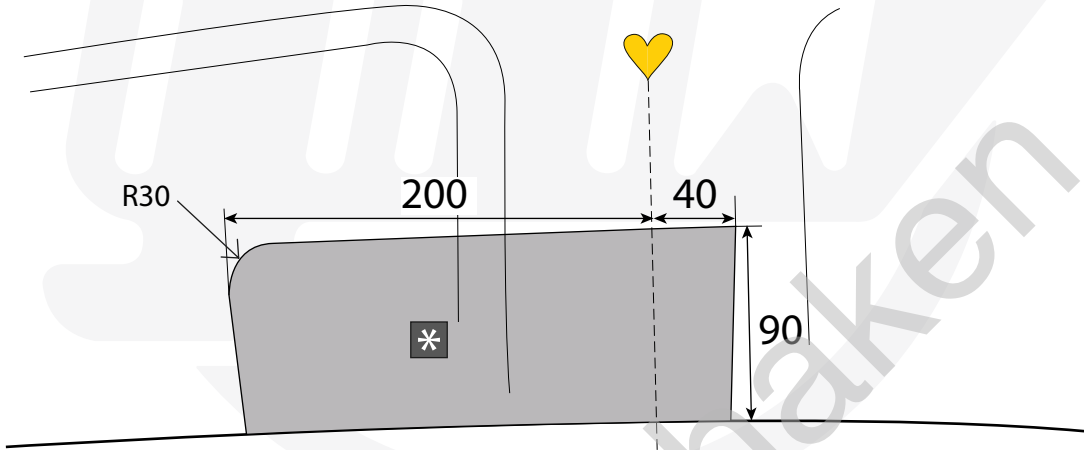
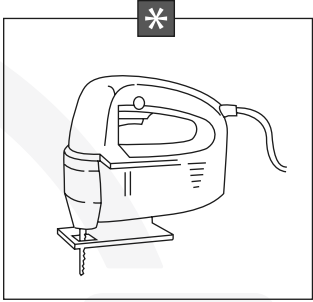

### Niro EV

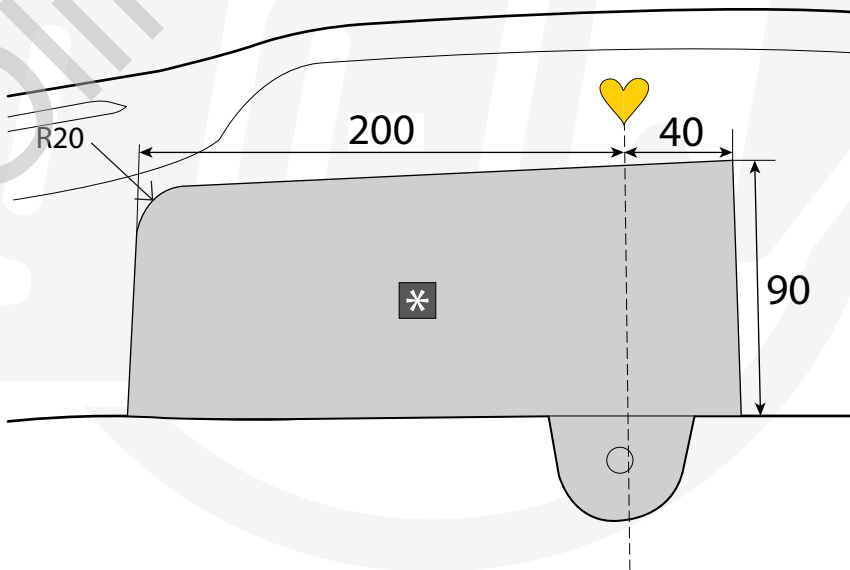
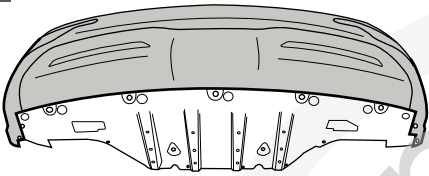
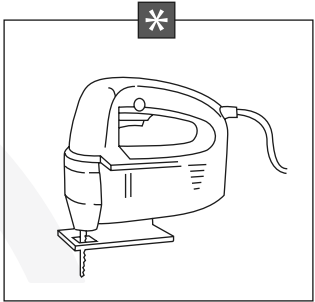



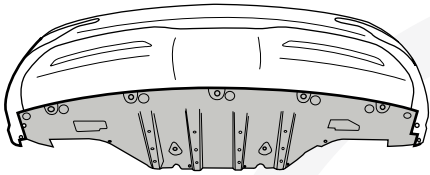

Niro EV

