



TREKHAKEN • ATTELAGES • ANHÄNGERVORRICHTUNGEN • TOWBARS • ENHANCES • ANHÆNGERTRÆK

Montagehandleiding | instructions de montage | Einbauanleitung | Mounting instruction
Instrucciones de montaje | monteringsvejledning



Ford Transit T2

05/'14-

- ✓ STANDARD
- ✓ E-TRANSIT

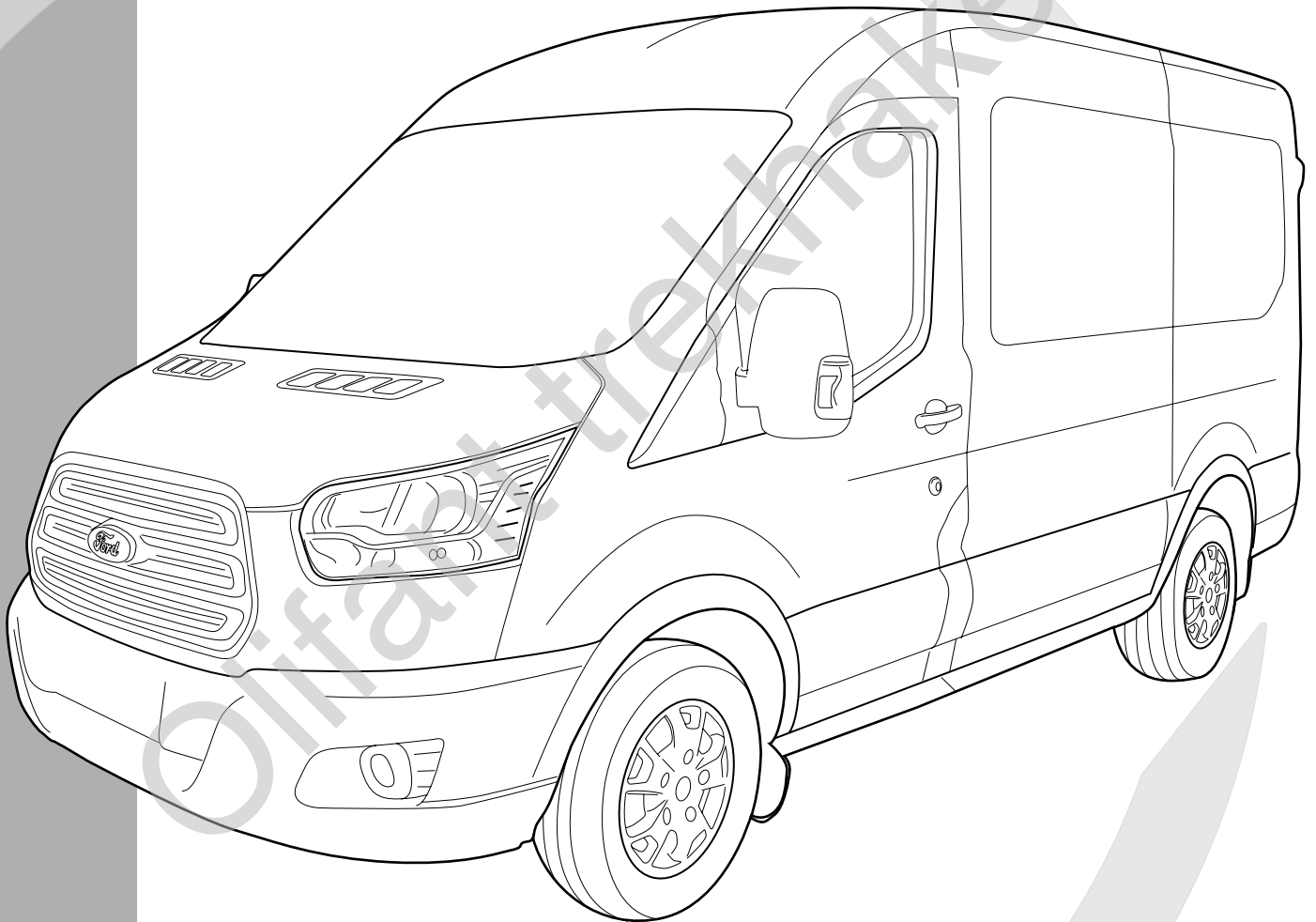

See the Certificate Of Conformity (COC) of your vehicle or contact your dealer to verify the max. trailer weight of your car!



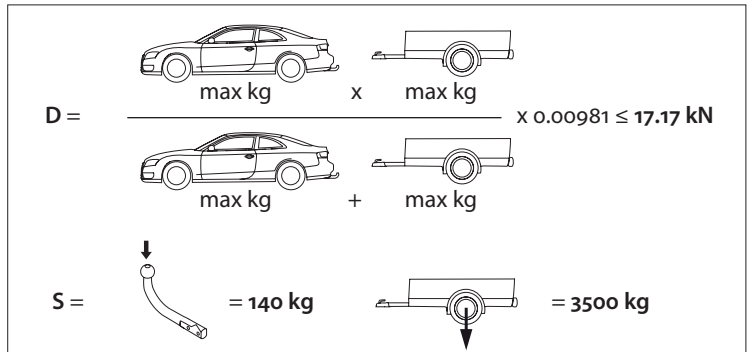



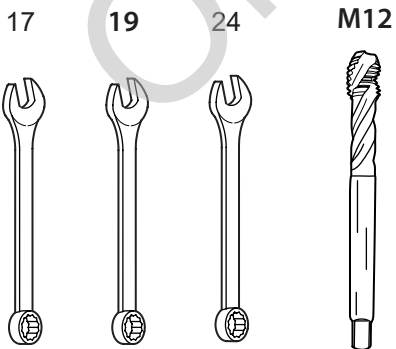
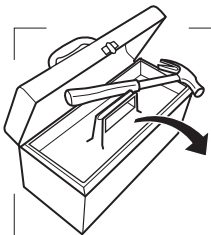

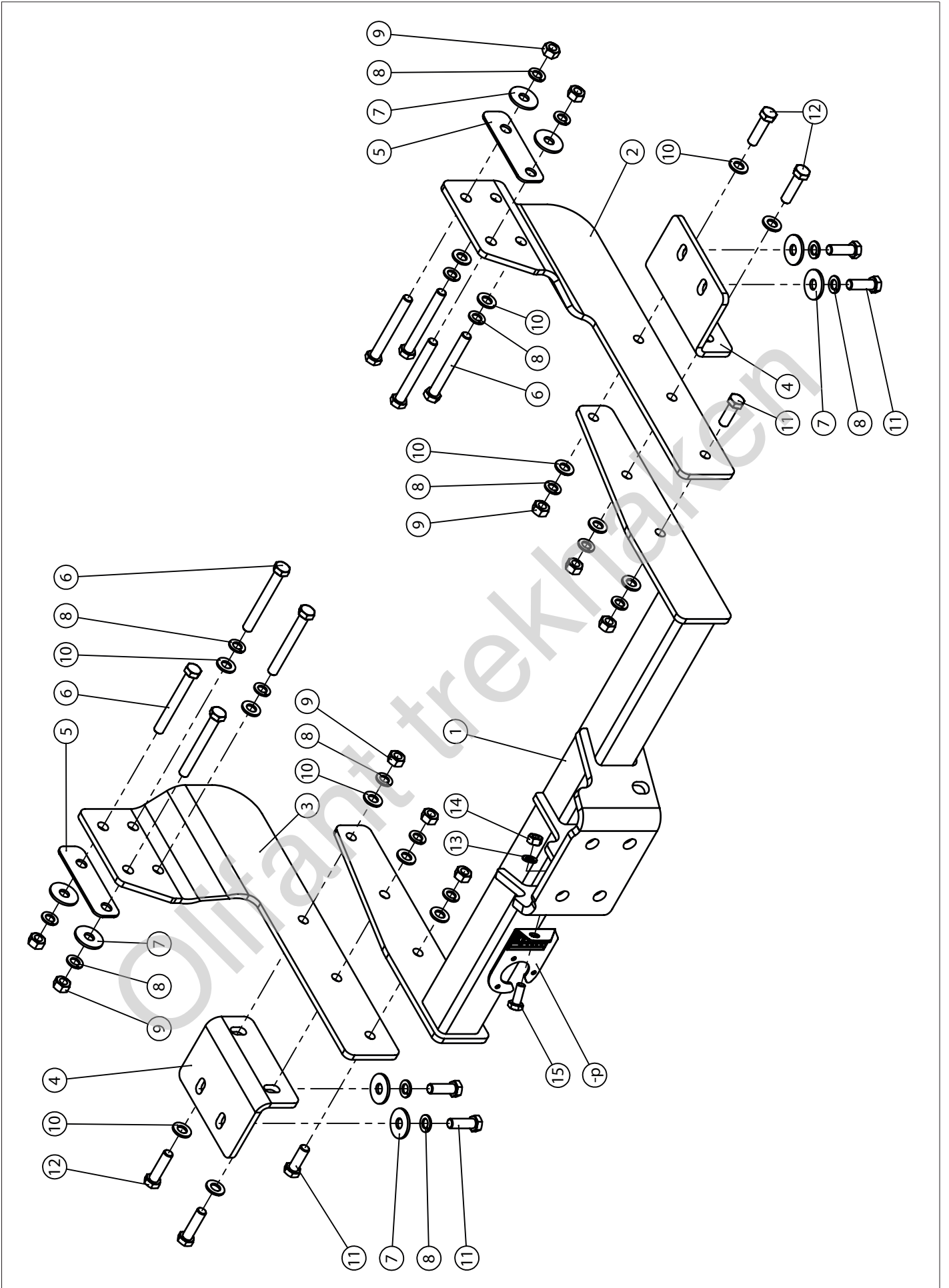

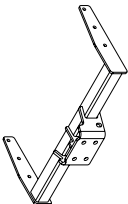
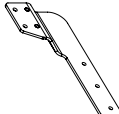
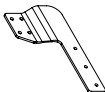



MADE BY	D 17.17	F	E6
		EC APPROVAL N°	
BELGIUM	S 140	55R-011160	
REF N°	SERIE N°		
OMSCHRIJVING			
Ford TransitT2 05/'14-			







	M 6	M 8	M 10	M 12	M 14	M 16
8.8	10,4 Nm	25,0 Nm	51,0 Nm	87,0 Nm	140,0 Nm	215,0 Nm
10.9	15,5 Nm	37,0 Nm	75,0 Nm	130,0 Nm	205,0 Nm	310, Nm
12.9	18,0 Nm	43,0 Nm	87,0 Nm	150,0 Nm	240,0 Nm	370,0 Nm



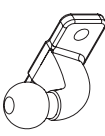

1		X1	GDW REF. 2039
2		X1	GDW REF. 2
3		X1	GDW REF. 3
4		X2	GDW REF. 4
5		X2	GDW REF. 5
6		X8	DIN931-M12X100
7		X8	DIN9021-M12-ELVZ Ø 37 X 13 X 3
8		X18	DIN128A-M12
9		X10	DIN934-M12
10		X14	DIN125-A12-140HV-ELVZ
11		X6	DIN933-M12X35
12		X4	DIN931-M12X45
13		X1	DIN128A-M10
14		X1	DIN934-M10
15		X1	DIN933-M10X25
-P		X1	GDW REF. P29

Geleverd met - Livré avec - Delivered with Geliefert mit - Elementos adjuntos-Leveres med		
	X1	50T
	X2	DIN128A-M16
	X2	DIN933-M16 X 50-10.9
	X2	DIN934-M16-10.9
	X2	DIN125-A16-140HV-ELVZ

1

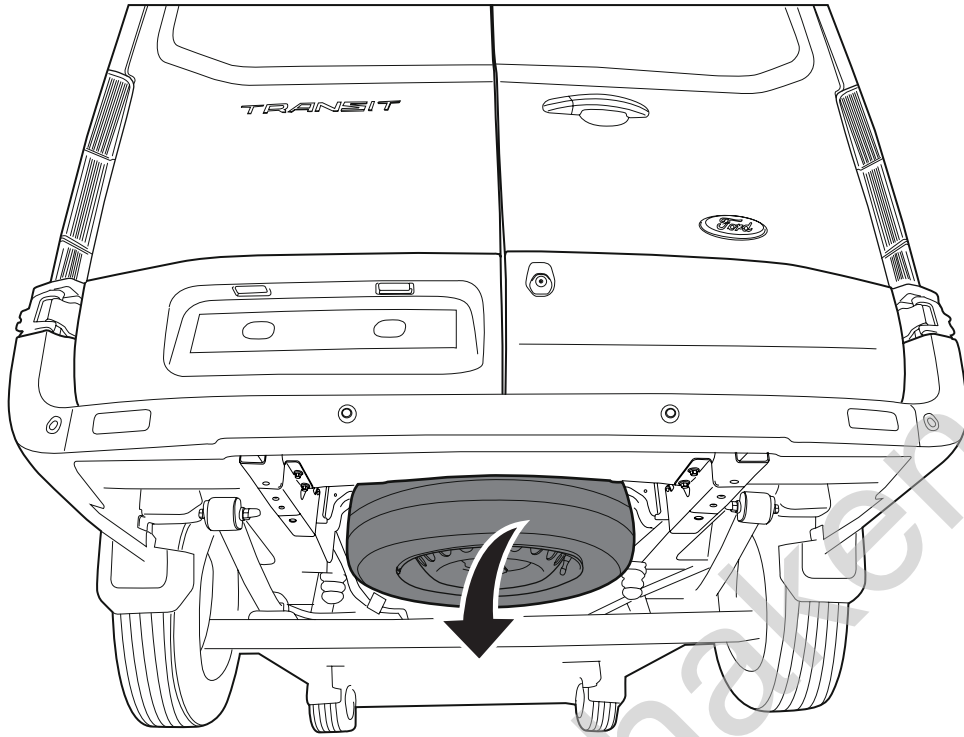

2

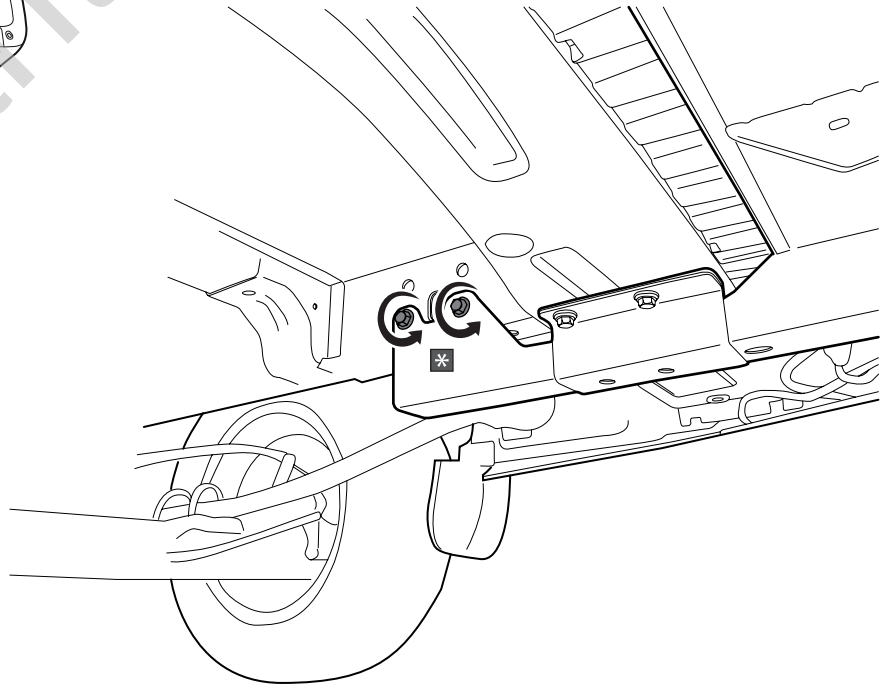
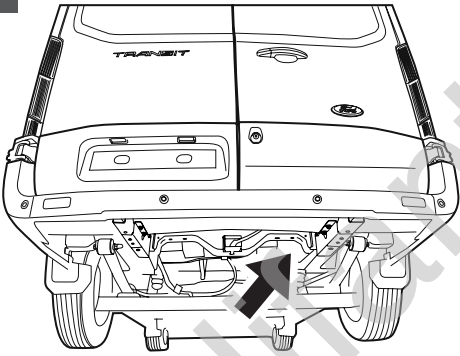

*

19



*

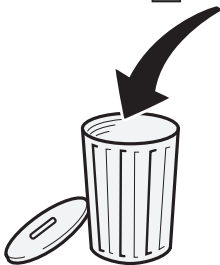

3

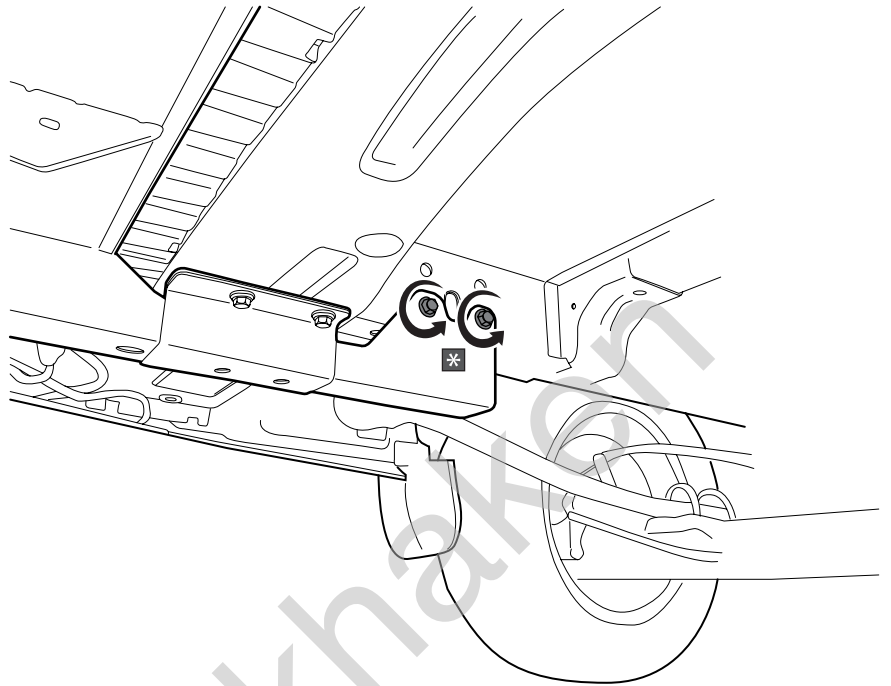
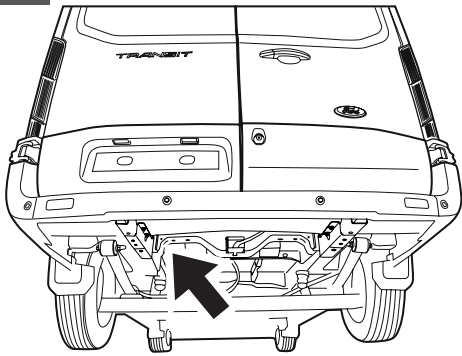

*

19

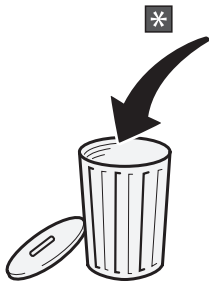

4

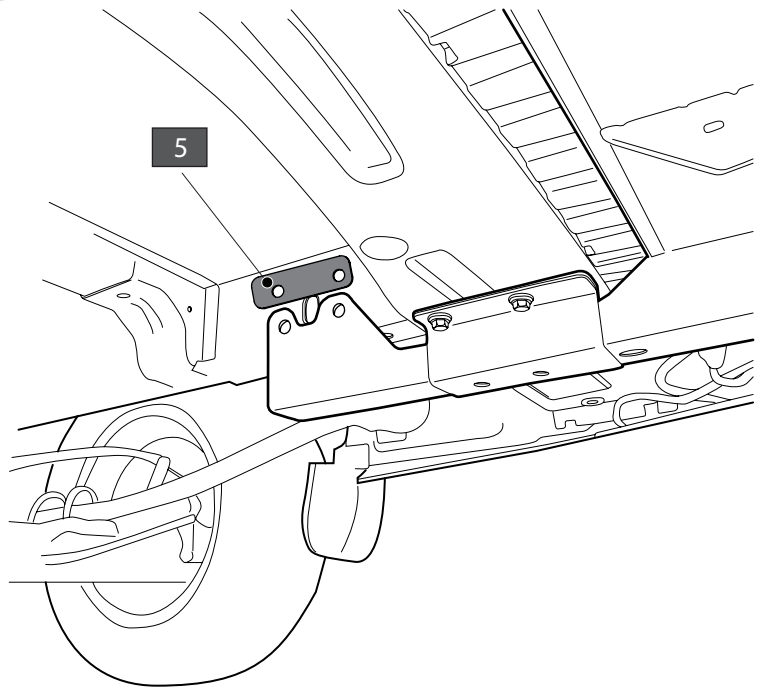
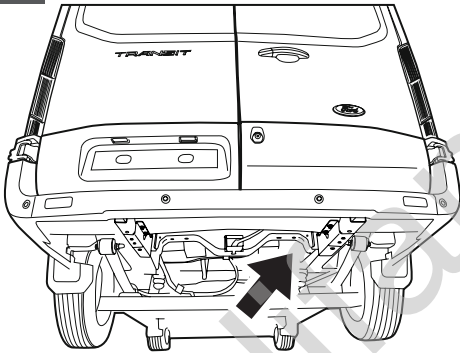

5

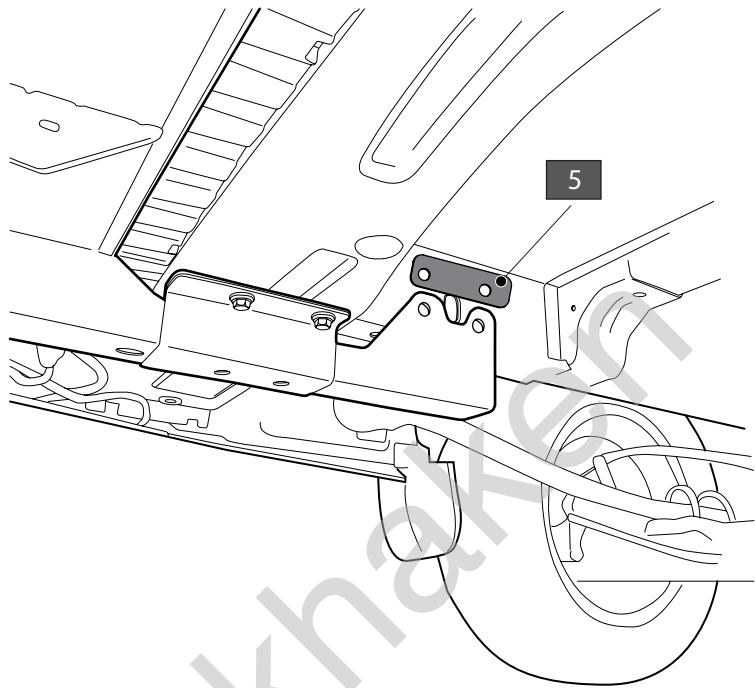
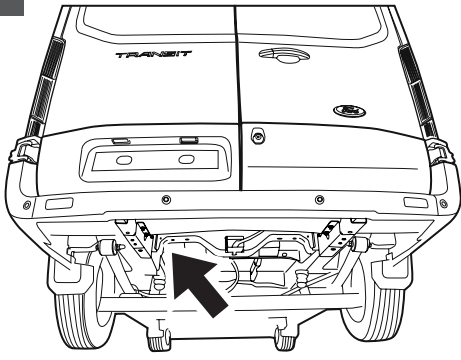

6

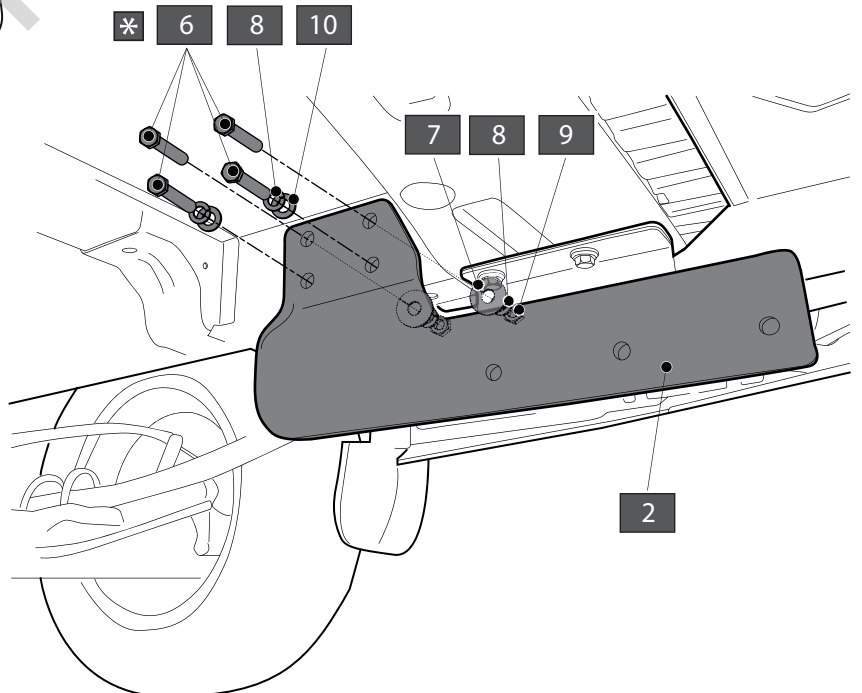
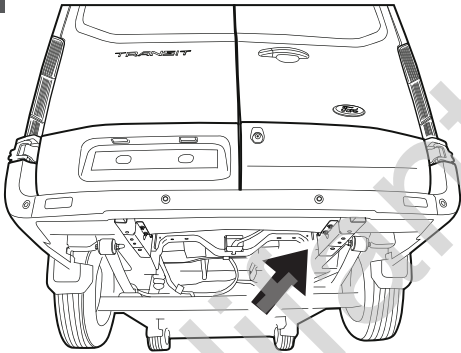

*

19



7

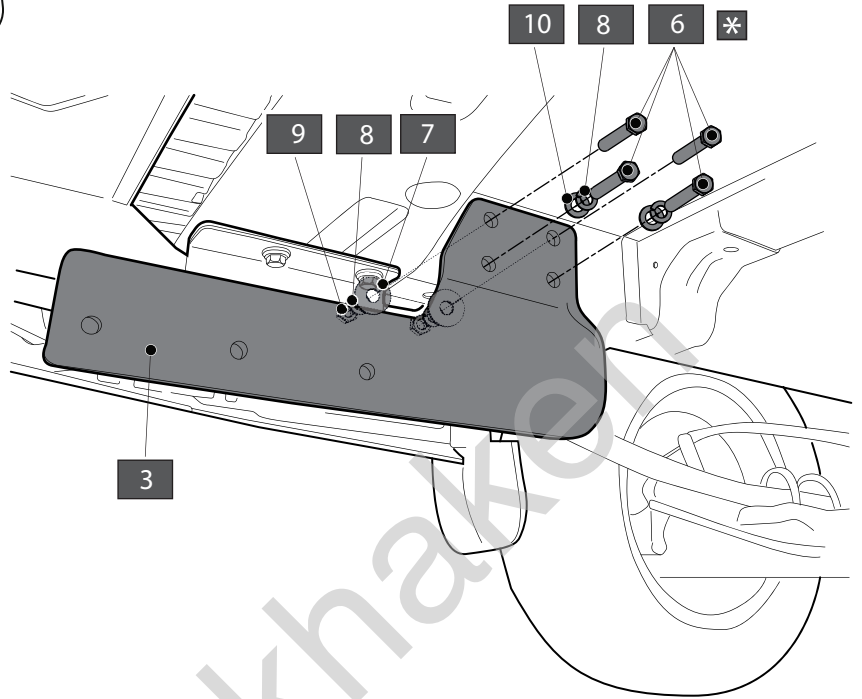
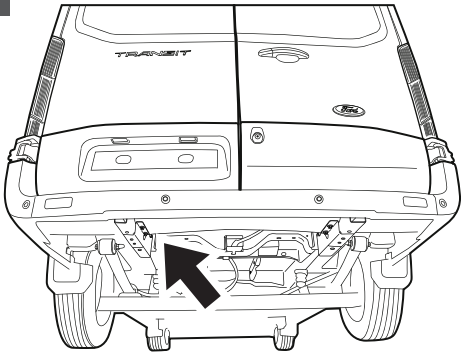

*

19



8

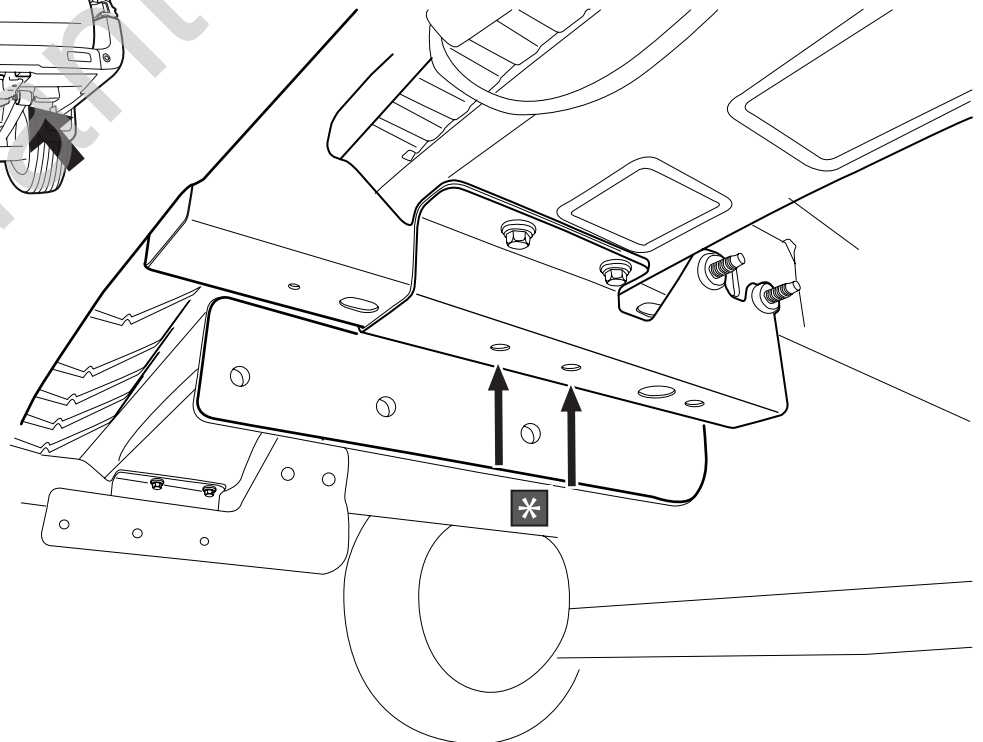
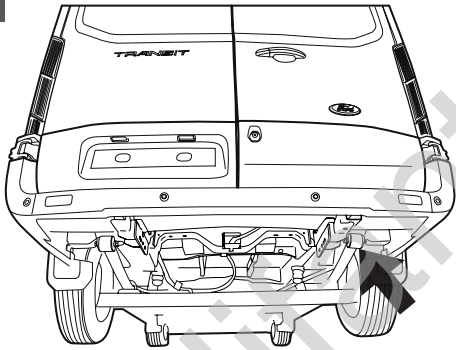

*

M12

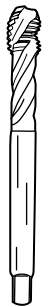

9

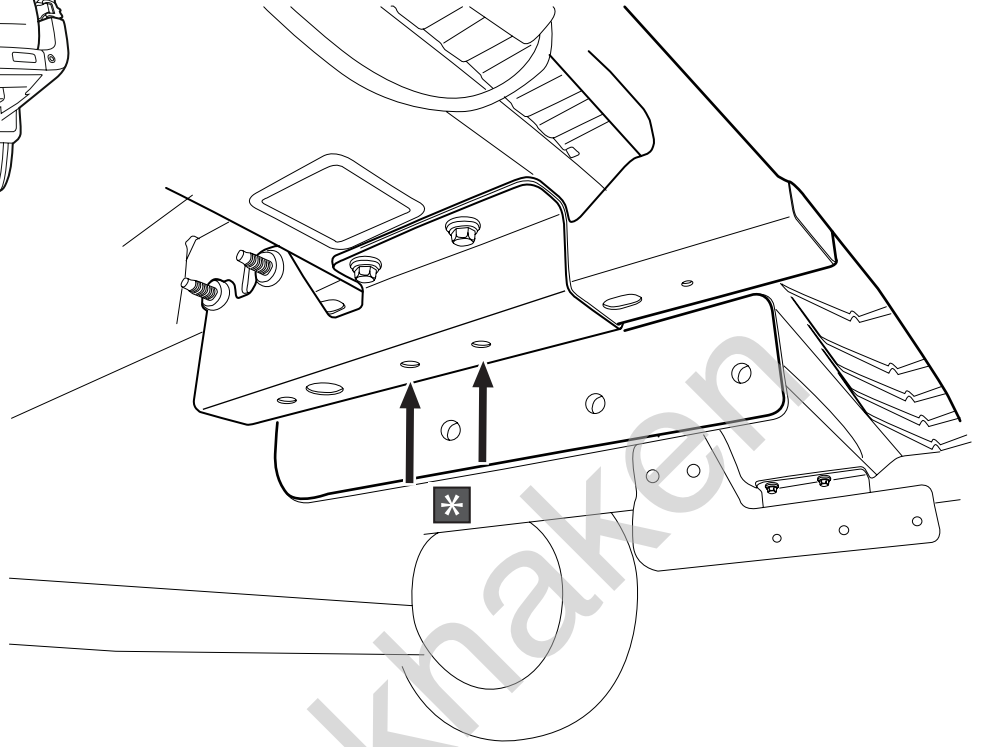
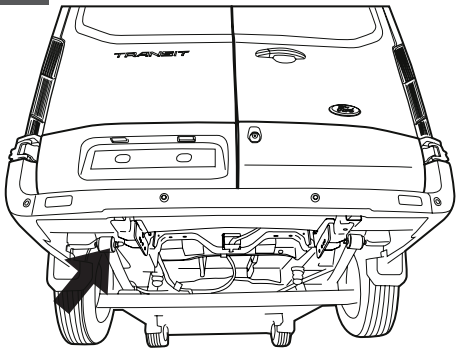

M12

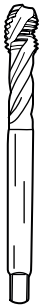

10

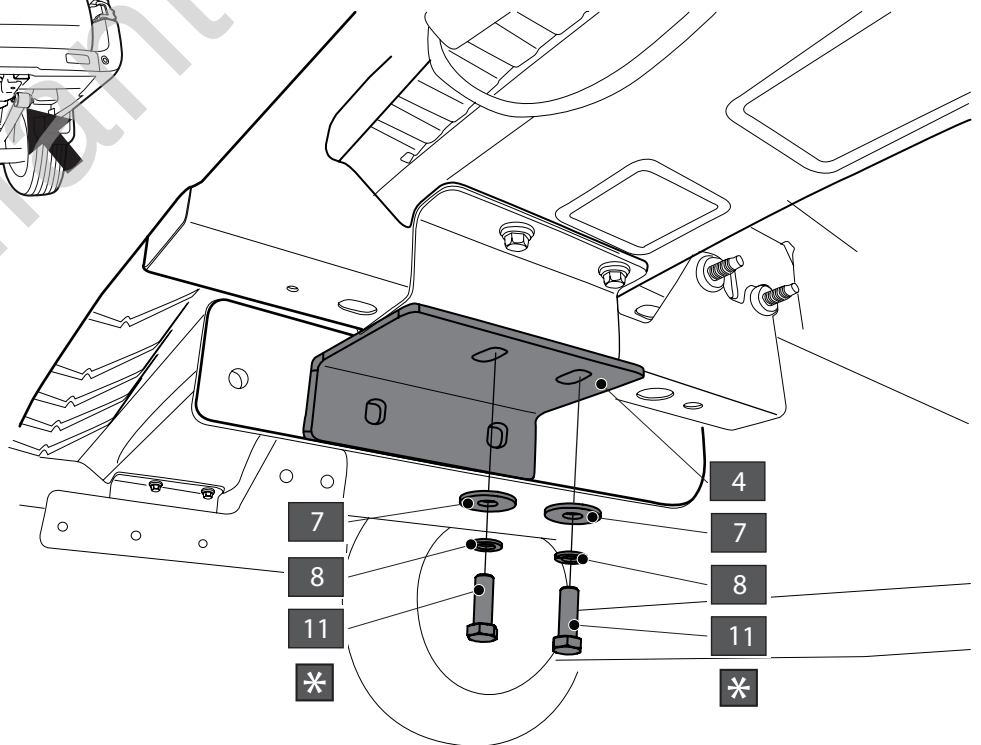
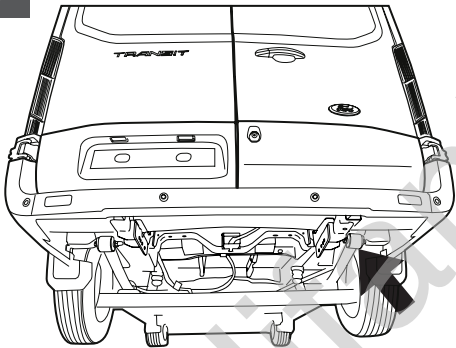

19

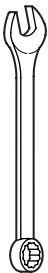

11

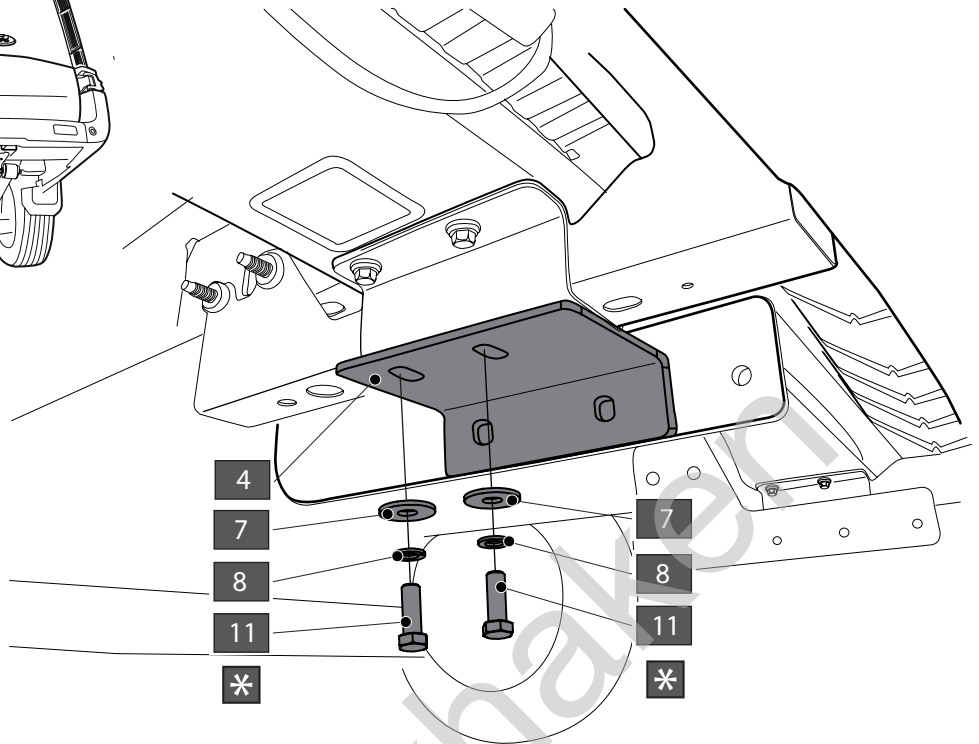
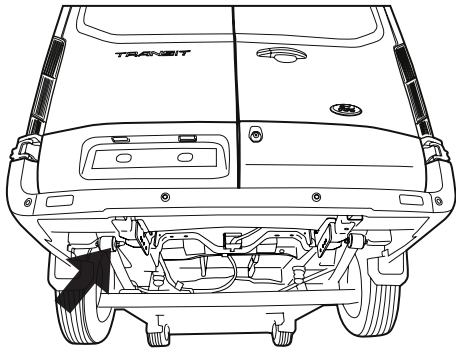

*

19



12

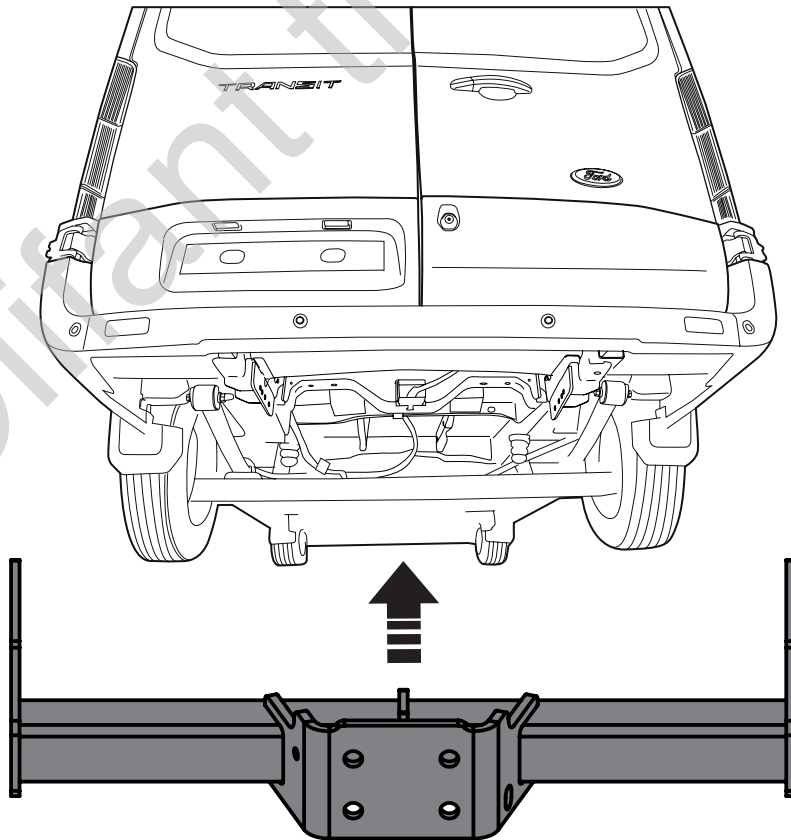

13

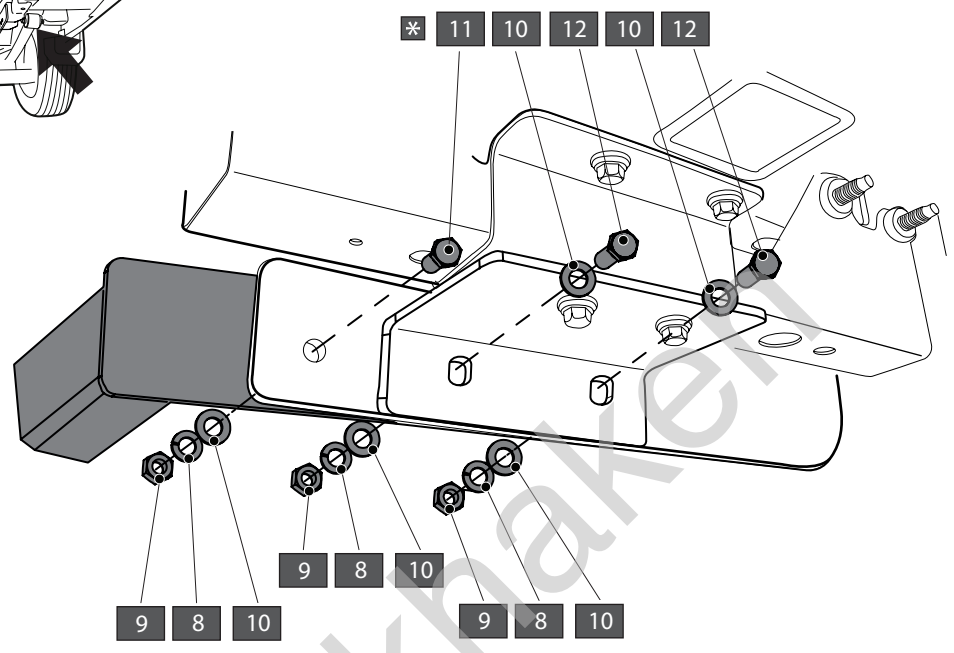
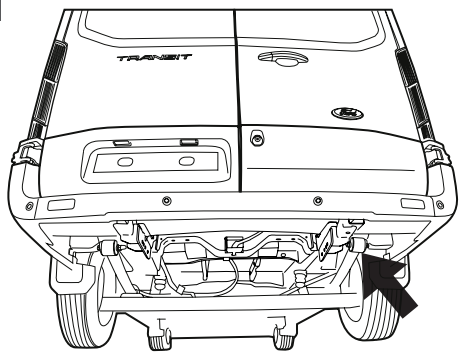

*
19

14

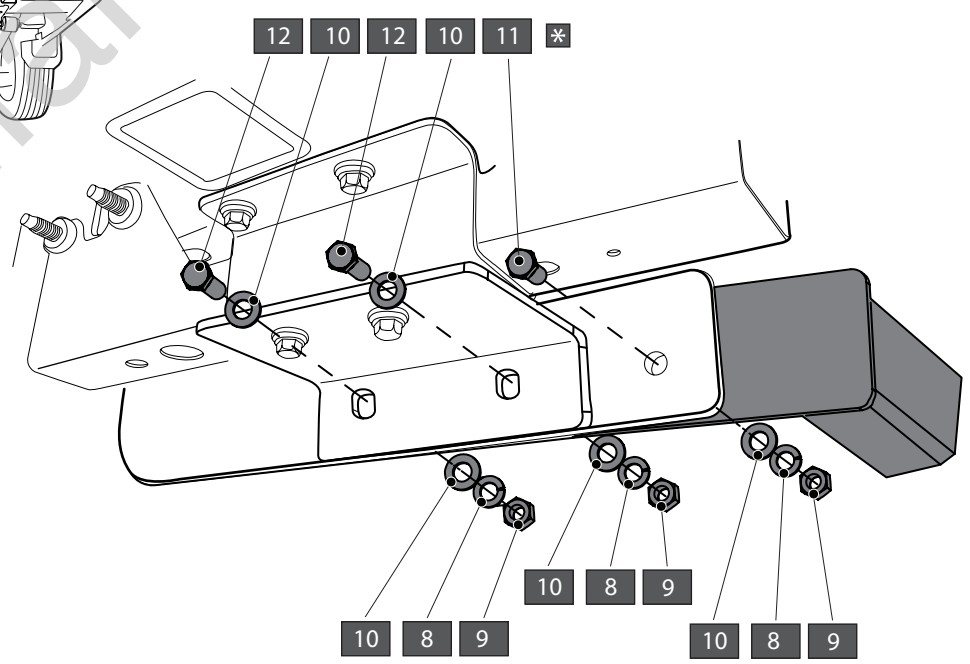
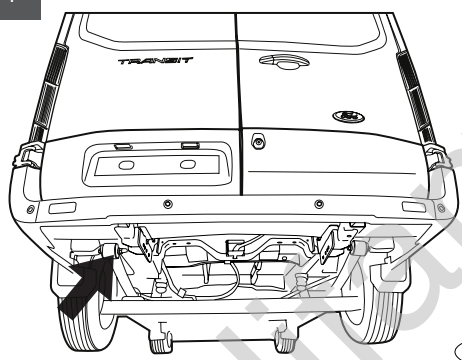

*
19

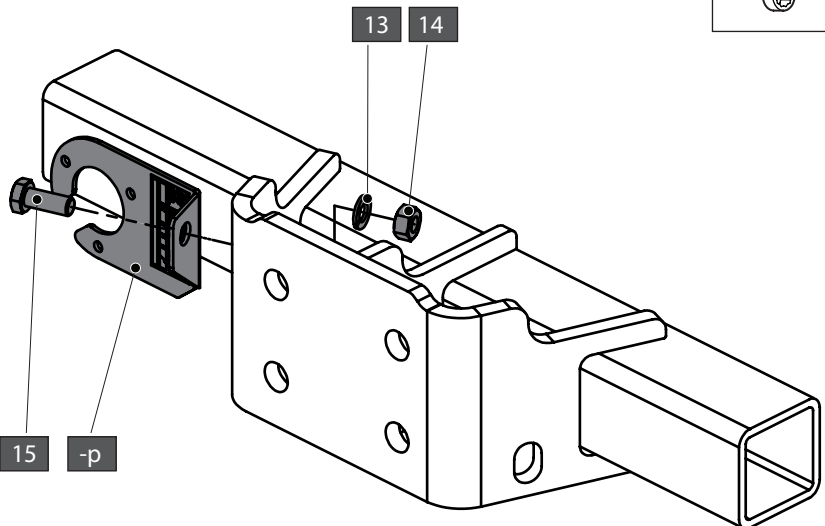
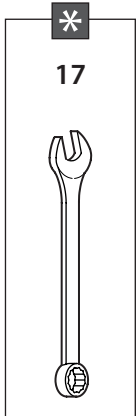
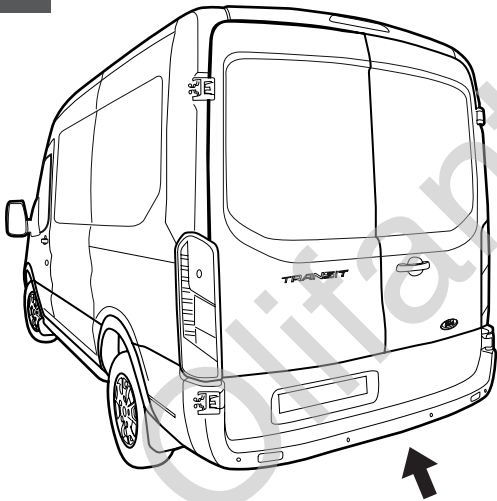
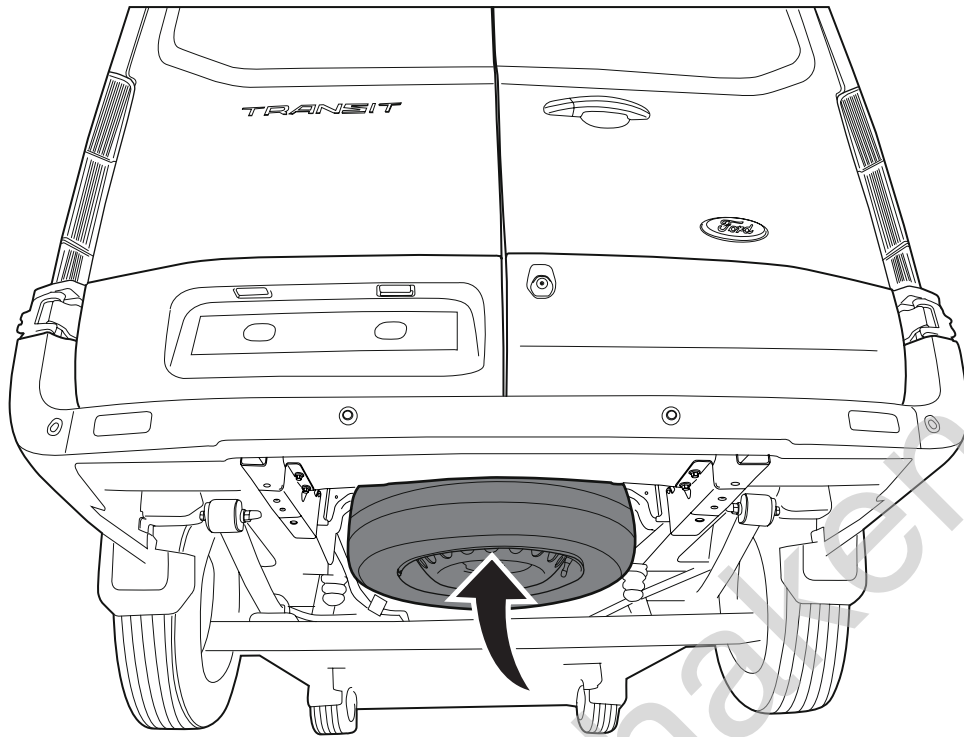

P		X1	GDW REF. P29
L		X1	DIN933-M10X25
L		X1	DIN128A-M10
L		X1	DIN934-M10

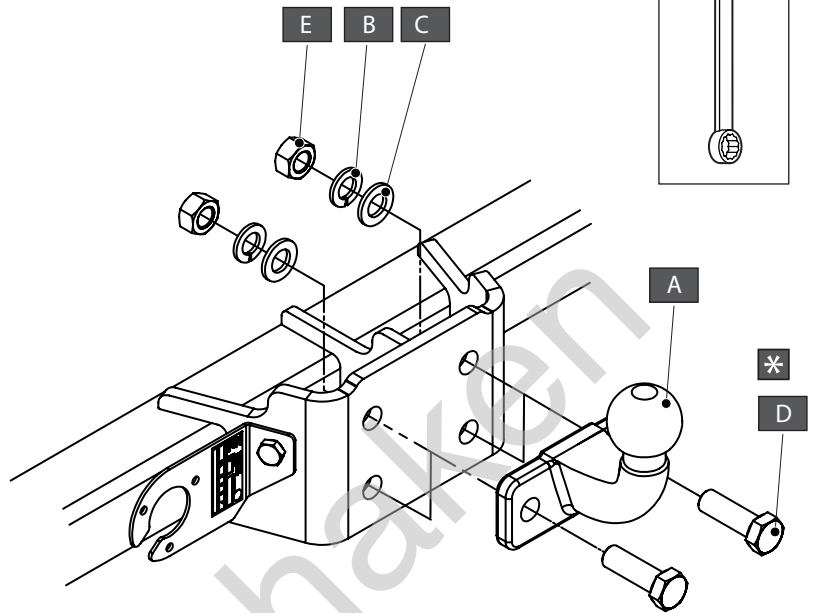
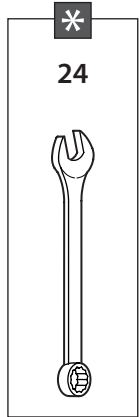
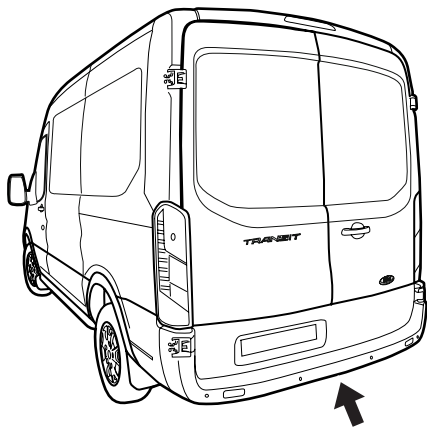

A		X1	50T
B		X2	DIN128A-M16
C		X2	DIN125-A16-140HV-ELVZ
D		X2	DIN933-M16 X 50-10.9
E		X2	DIN934-M16-10.9

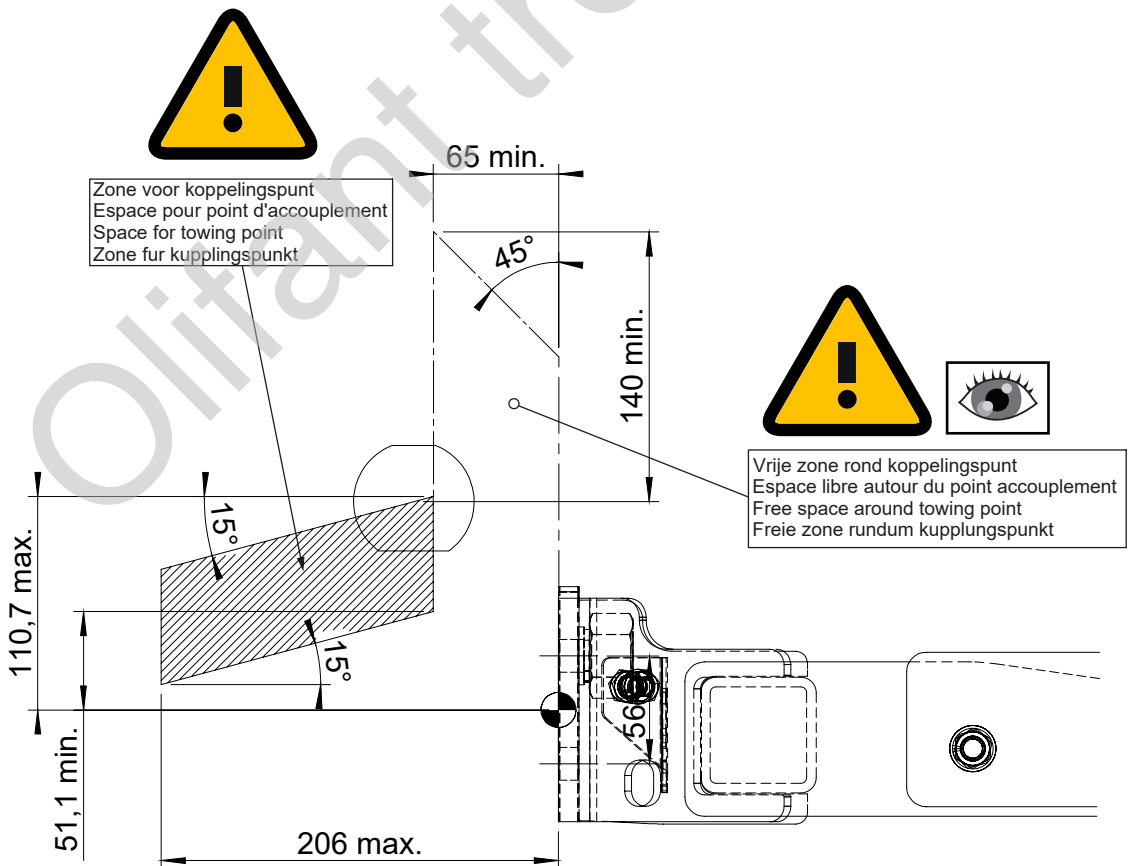

RK100WISSE —
RK100BASIS —
RK100KAP —

RK243U115E 740.010 740.011

UNISTEP 630.100
UNISTEP 630.110

740.043

Art. **ADAPT83x56**

Warning icon (yellow triangle with exclamation mark) and a shopping cart icon.

Warning icon (yellow triangle with exclamation mark) and two diagrams of a component with a hole. The first diagram shows a hole with a green checkmark, and the second shows a hole with a red X.

