



TREKHAKEN • ATTELAGES • ANHÄNGERVORRICHTUNGEN • TOWBARS • ENHANCES • ANHÆNGERTRÆK

Montagehandleiding | instructions de montage | Einbauanleitung | Mounting instruction  
Instrucciones de montaje | monteringsvejledning



## Toyota Verso S

'01/11-

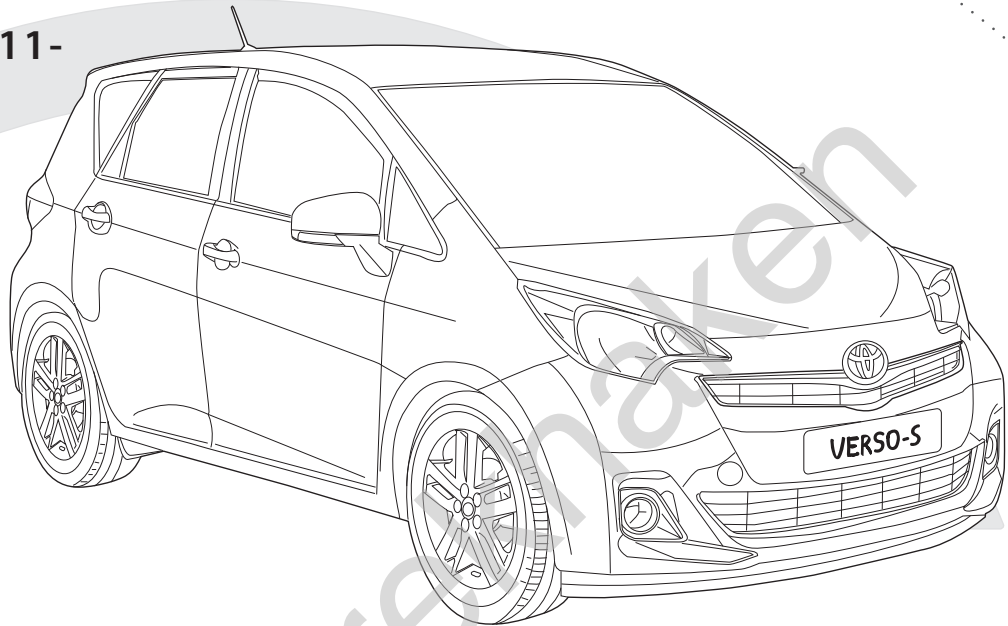

## Subaru Trezia

'03/11-

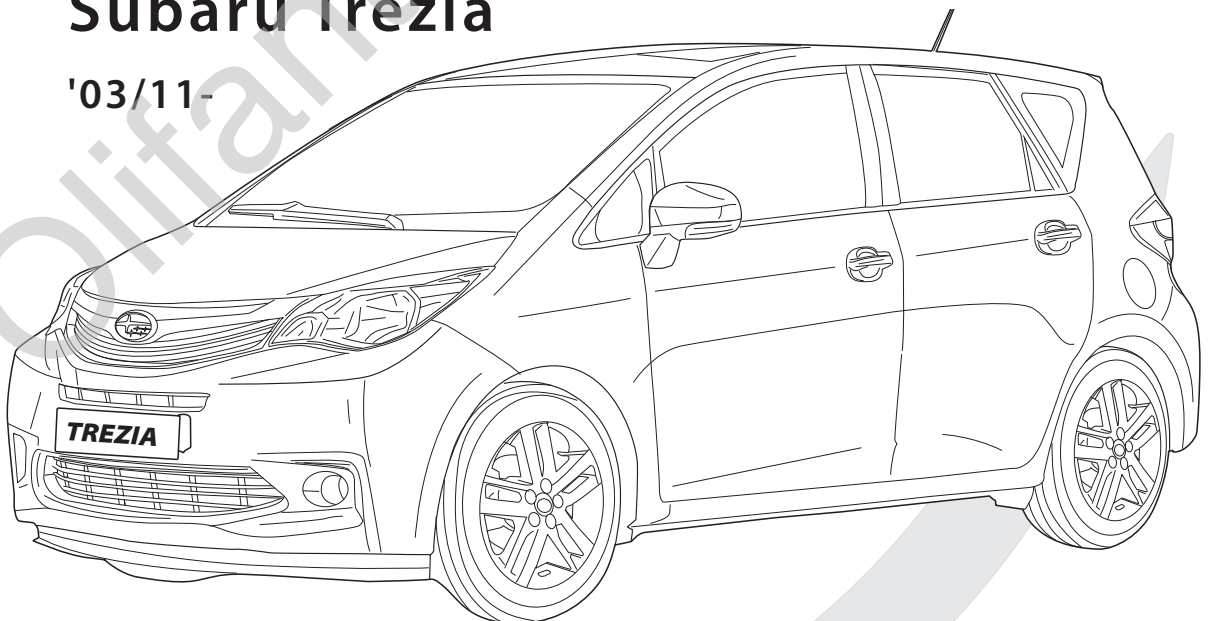

MADE BY **D 5,65** **F** **e6**

BELGIUM **S 55** **00 - 0957**

EC APPROVAL N°

REF N° **1859** SERIE N° **XXXX**

OMSCHRIJVING  
Toyota Verso S '01/11- | Subaru Trezia '03 /11-

max kg  $\times$  max kg  $\times 0.00981 \leq 5,65$  kN  
 $D = \frac{\text{max kg} + \text{max kg}}{\text{max kg} + \text{max kg}}$







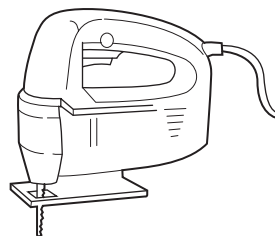
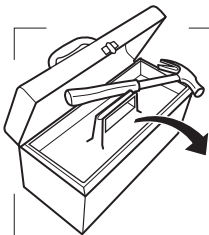

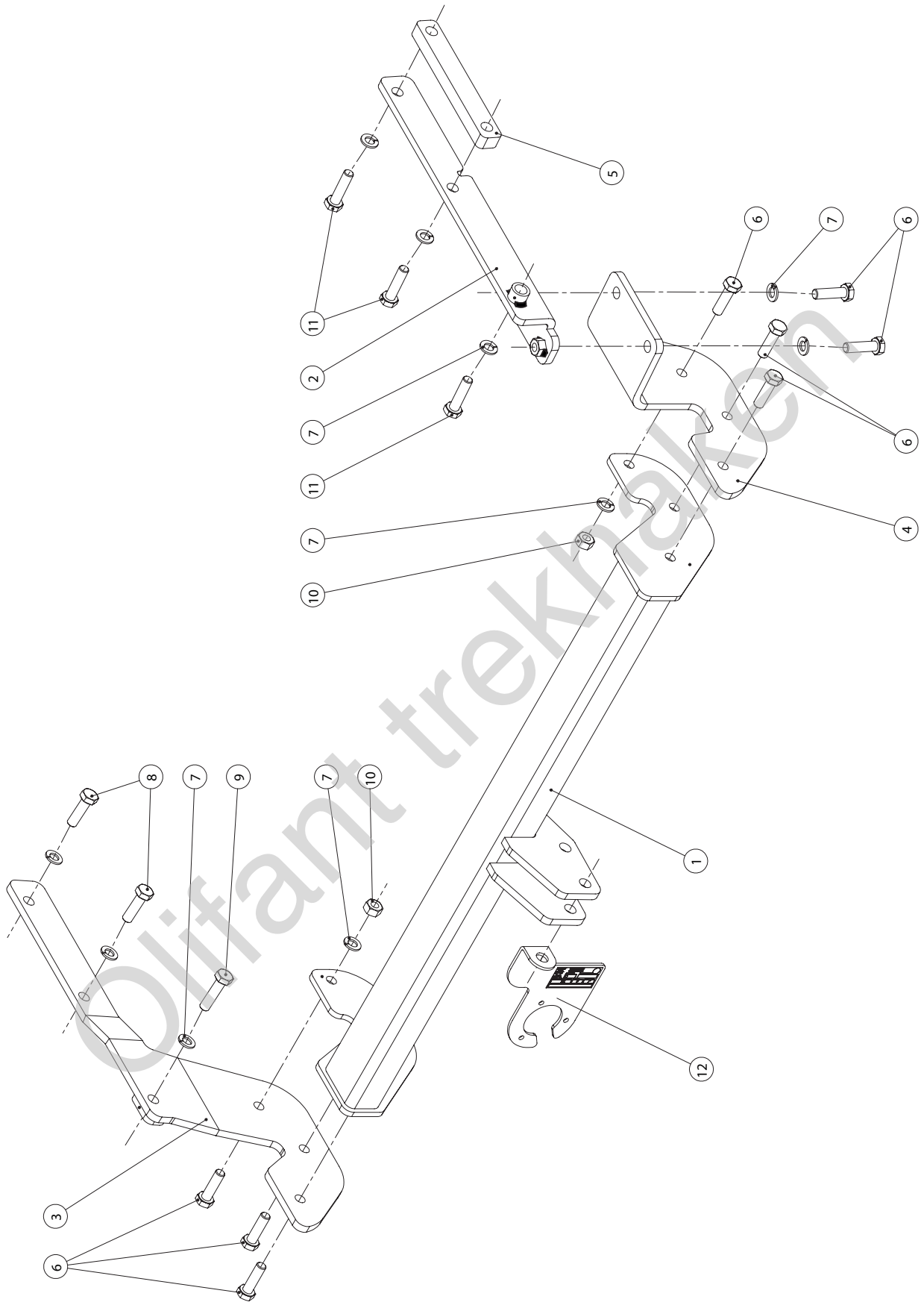
$S =$  = 55 kg = 900 kg

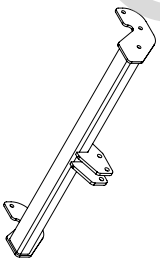
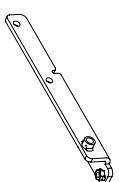
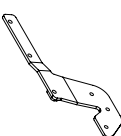
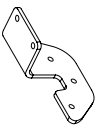







	M 6	M 8	M 10	M 12	M 14	M 16
8.8	10,4 Nm	25,0 Nm	51,0 Nm	87,0 Nm	140,0 Nm	215,0 Nm
10.9	15,5 Nm	37,0 Nm	75,0 Nm	130,0 Nm	205,0 Nm	310, Nm
12.9	18,0 Nm	43,0 Nm	87,0 Nm	150,0 Nm	240,0 Nm	370,0 Nm

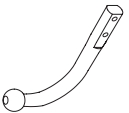



1		X1	GDW REF. 1859
2		X1	GDW REF. 2
3		X1	GDW REF. 3
4		X1	GDW REF. 4
5		X1	GDW REF. 5
6		X8	DIN933-M10X35
7		X14	DIN128A-M10
8		X2	DIN961-M10X35-1.25
9		X1	DIN961-M10X40-1.25
10		X6	DIN934-M10
11		X3	DIN961-M10X45-1.25
12		X1	GDW REF. PO4

Geleverd met - Livré avec - Delivered with Geliefert mit - Elementos adjuntos-Leveres med		
	X1	T45H031
	X2	GDW REF. 800008
	X2	GDW REF. 800011 Ø 21.3 X 11.7
	X1	GDW REF. 800053
	X4	DIN931-M12 X 70
	X4	DIN985-M12

1

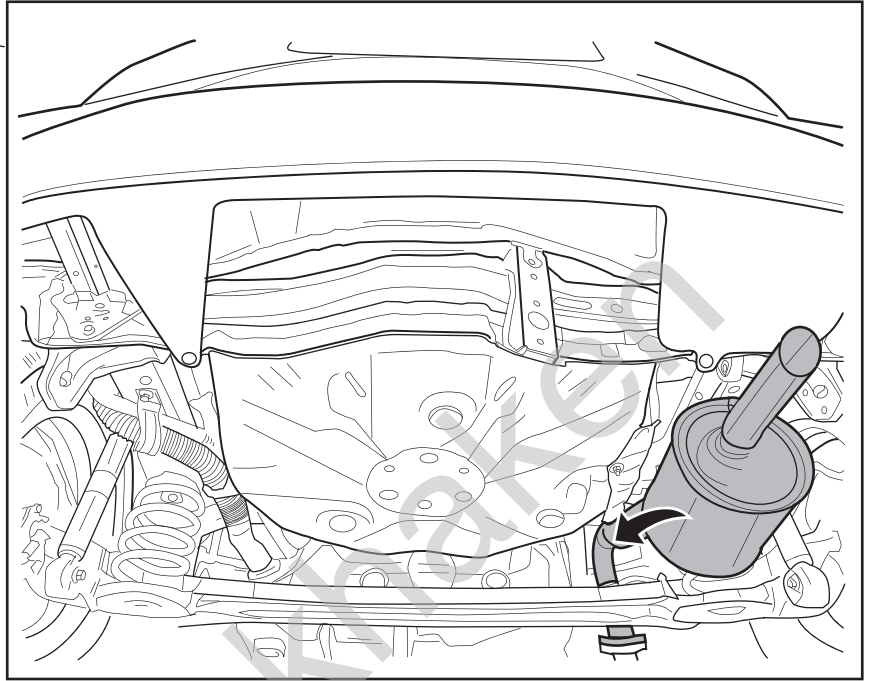
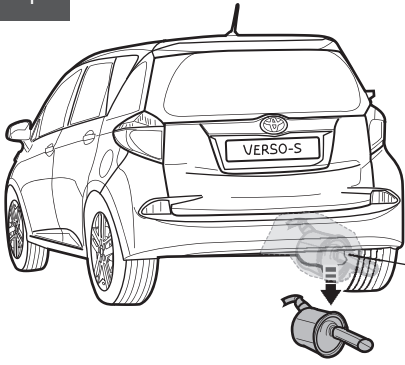

2

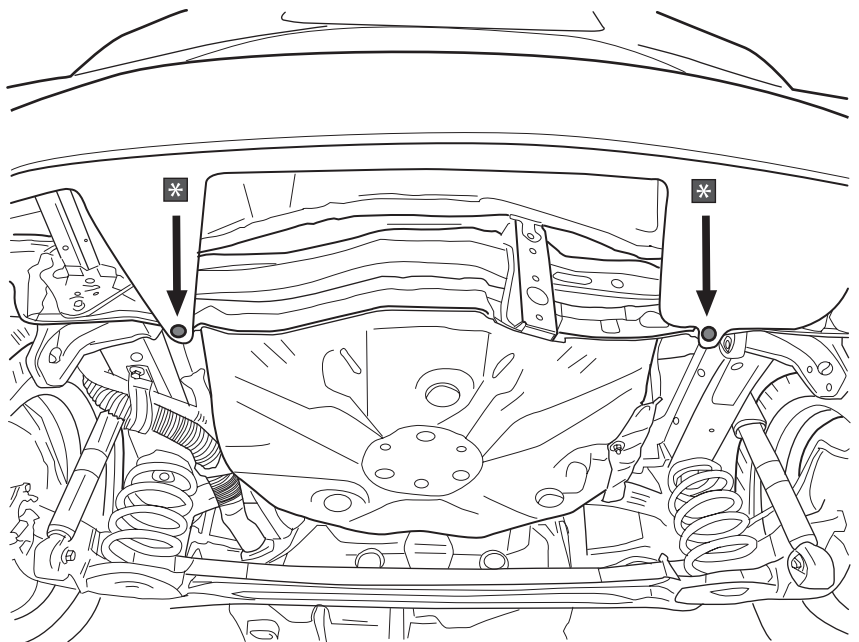
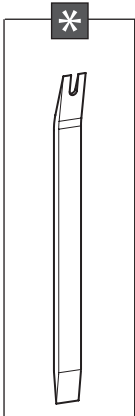
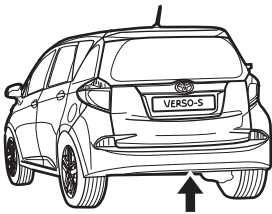

3

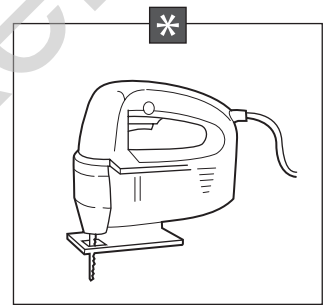
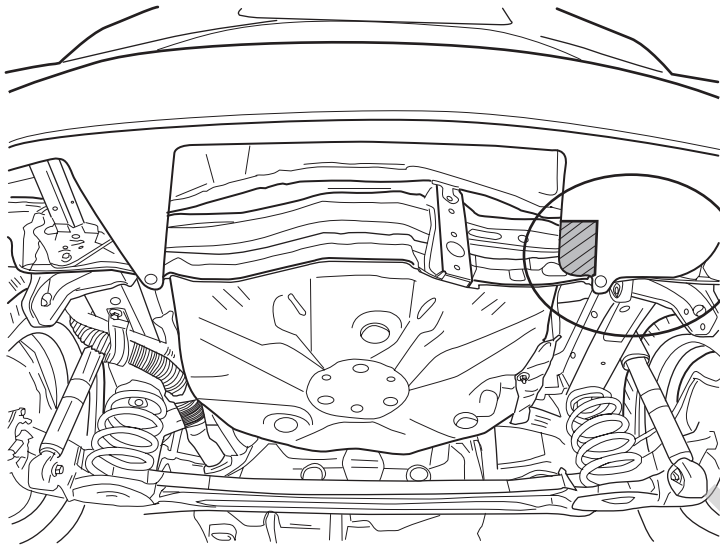
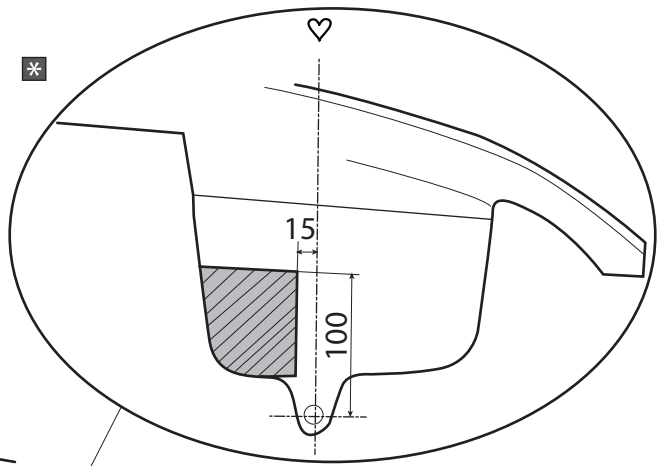
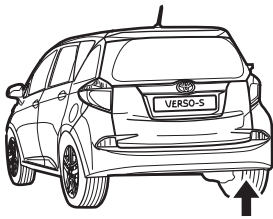

4

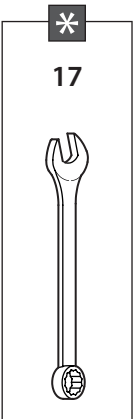
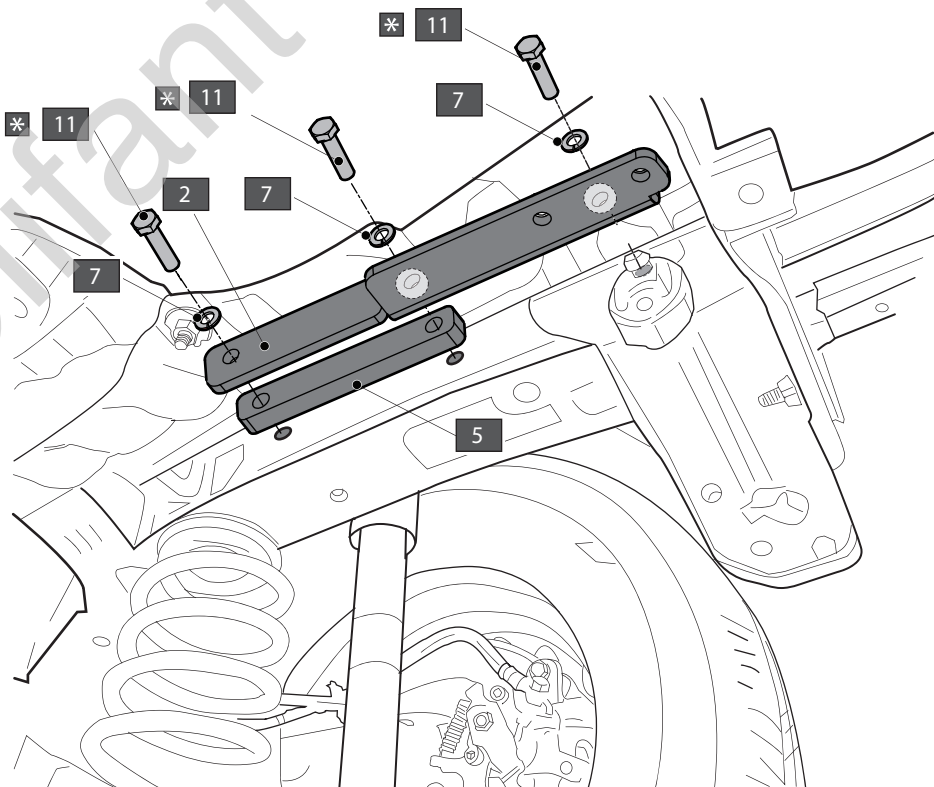
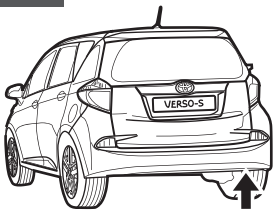



7

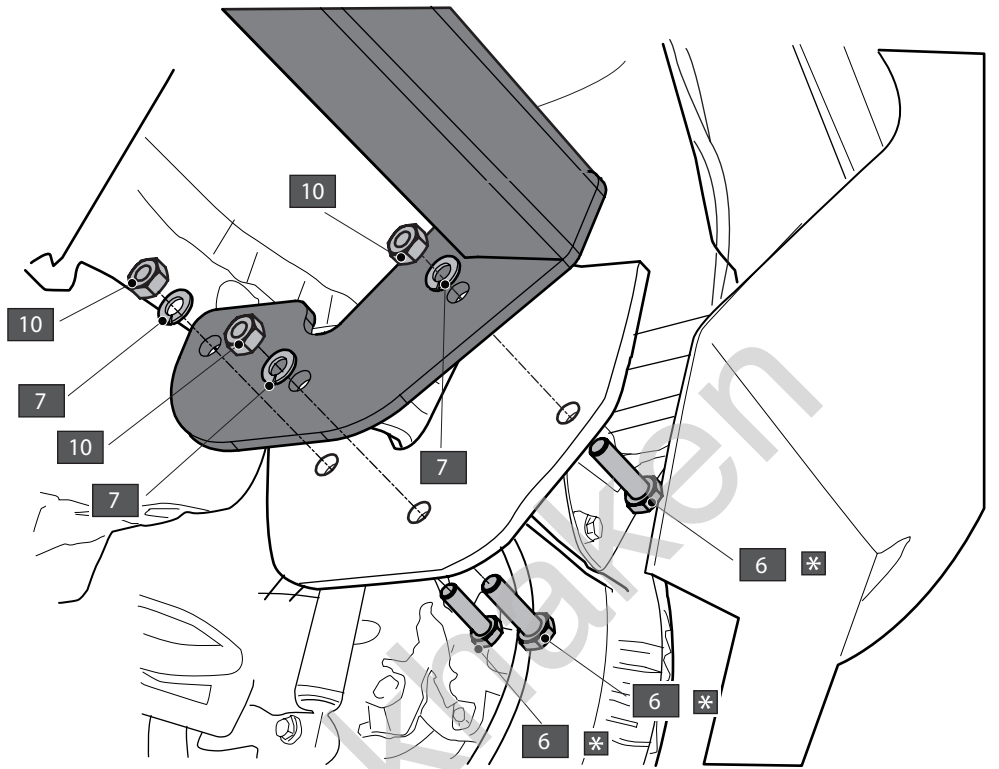
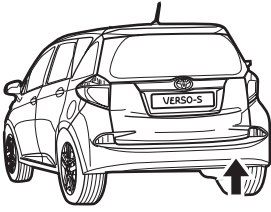



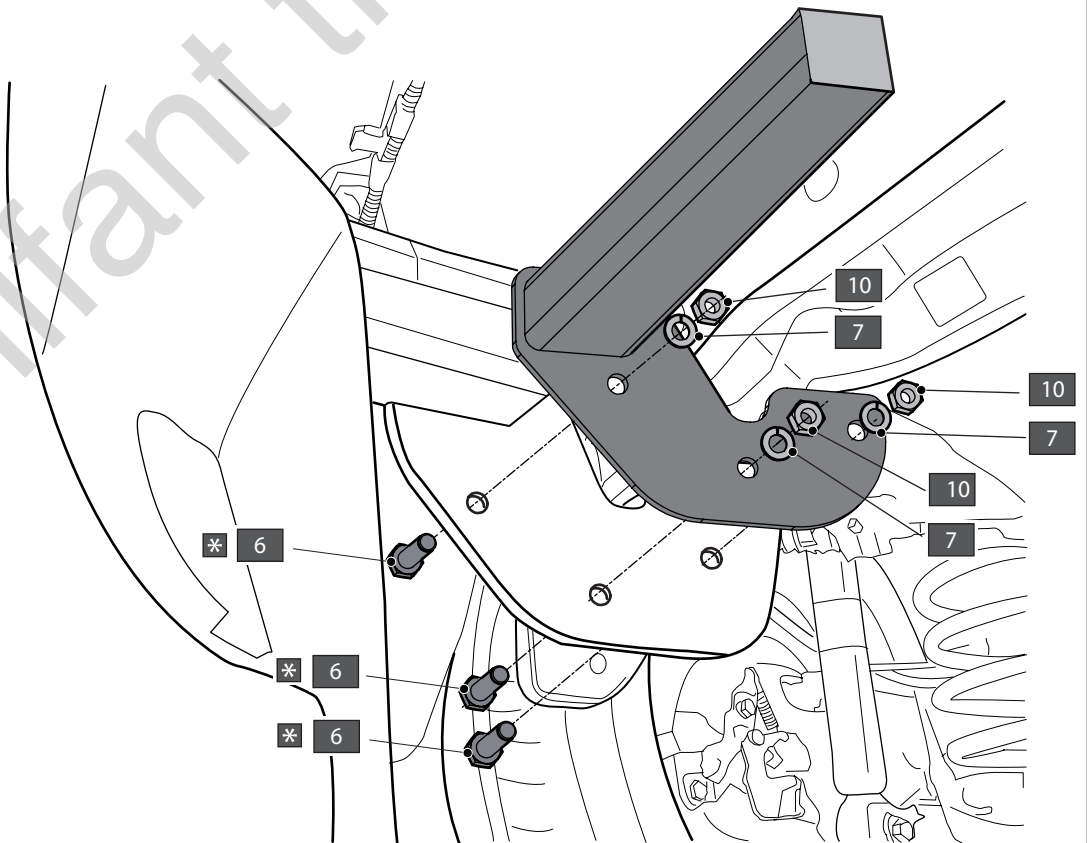
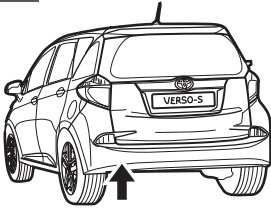

8

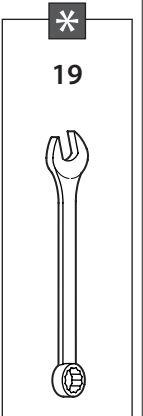
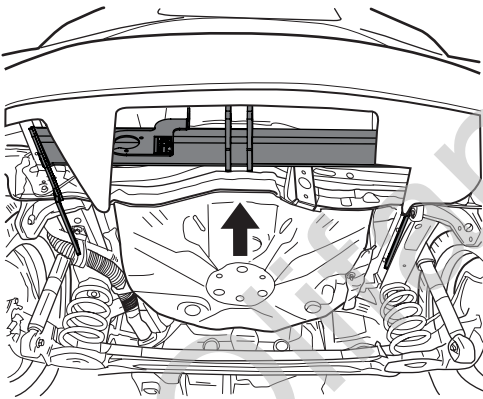
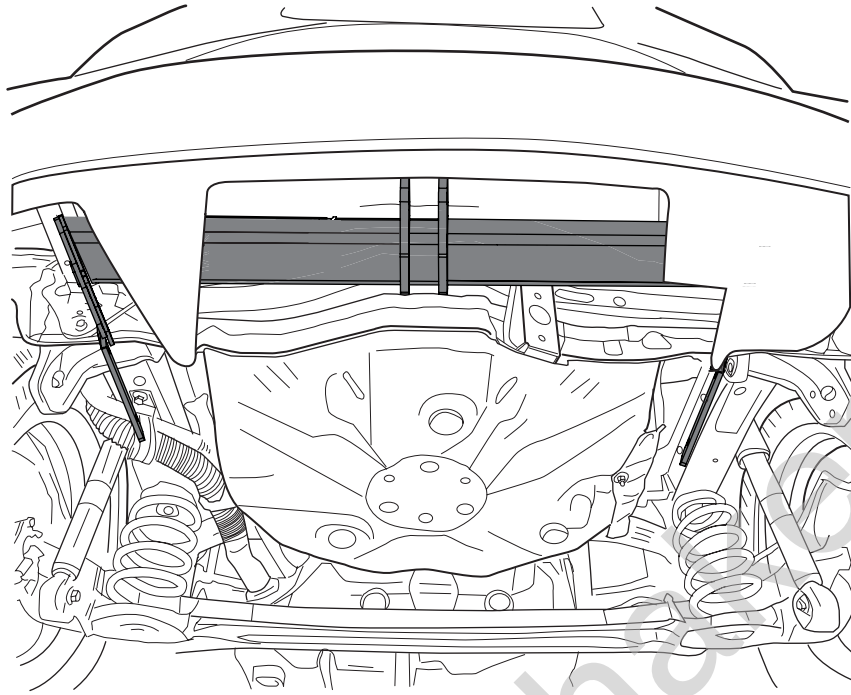



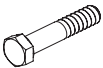

B		X2	GDW REF. 800008
C		X2	GDW REF. 800011 Ø 21.3 X 11.7
E		X2	DIN931-M12 X 70
F		X2	DIN985-M12

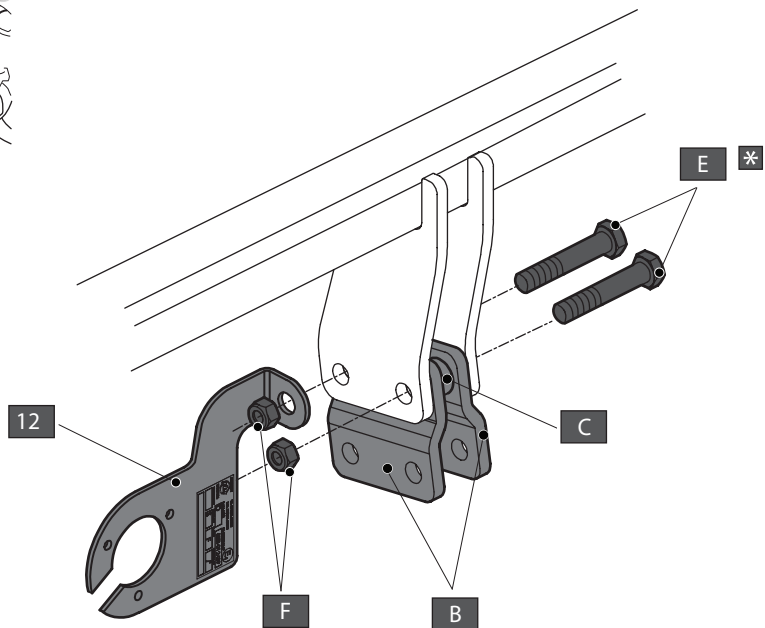

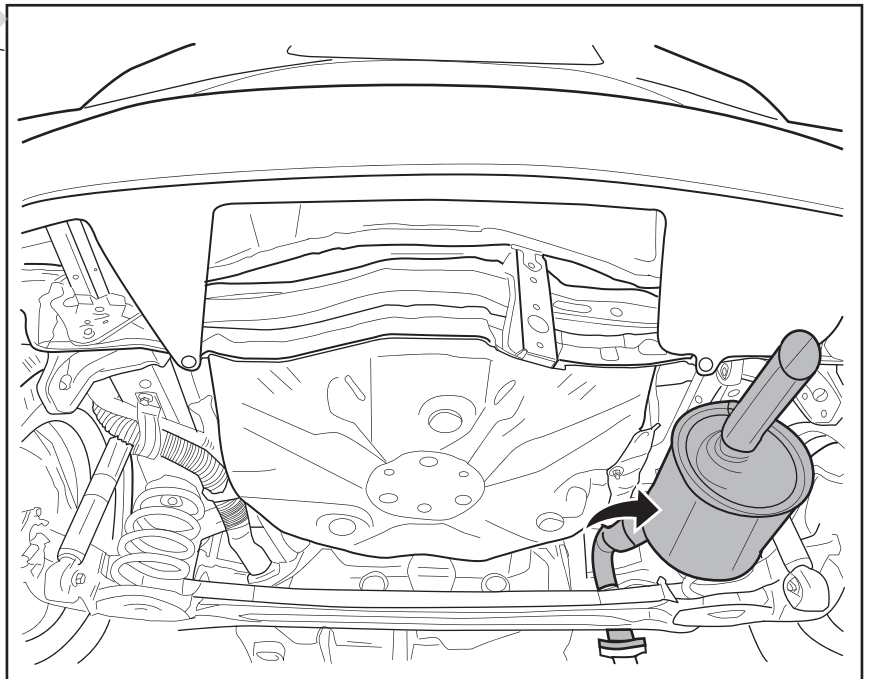
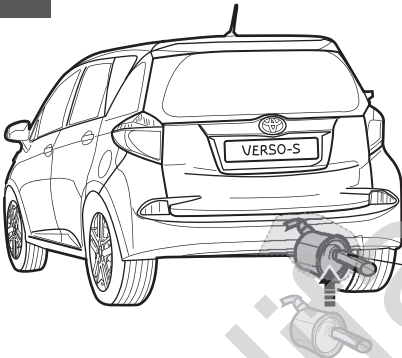
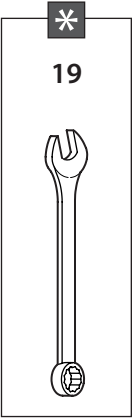
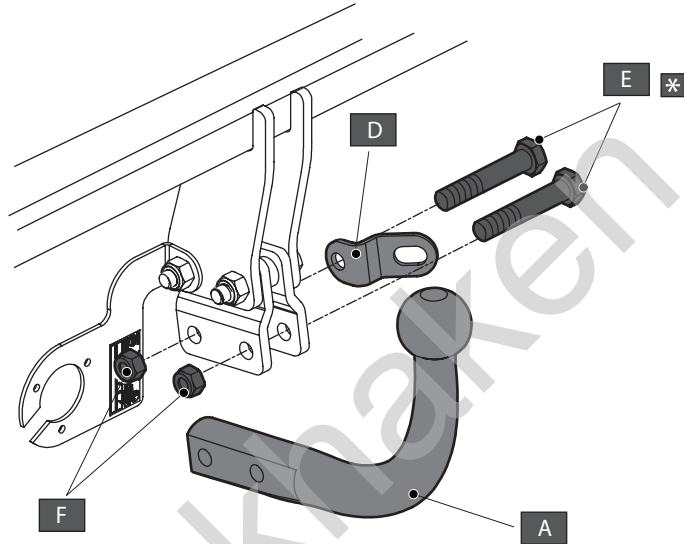
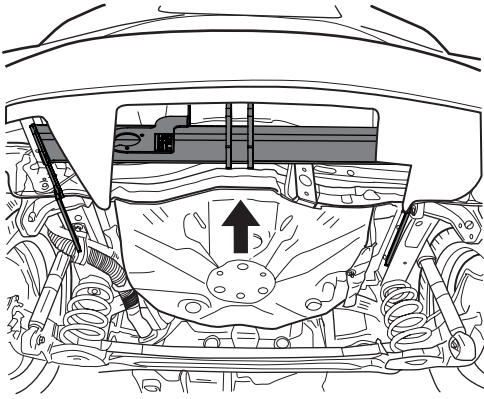

A		X1	T45H031
D		X1	GDW REF. 800053
E		X2	DIN931-M12 X 70
F		X2	DIN985-M12

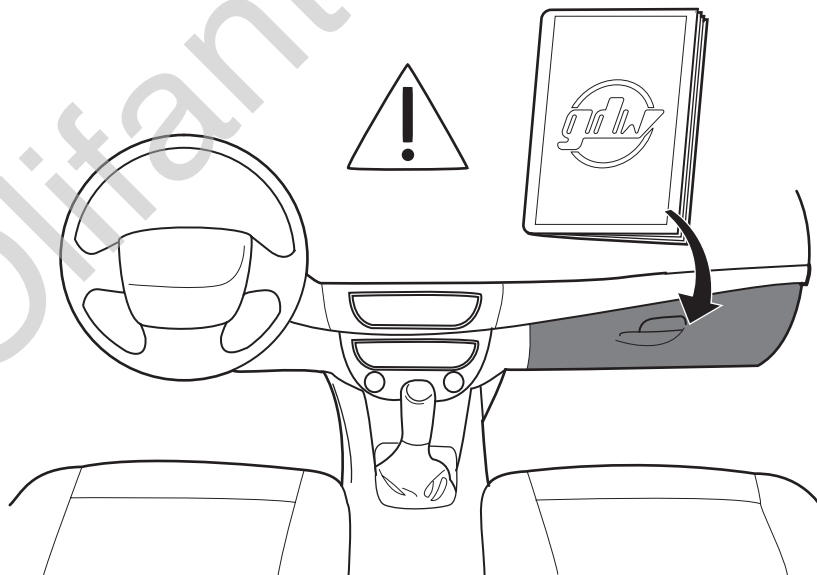
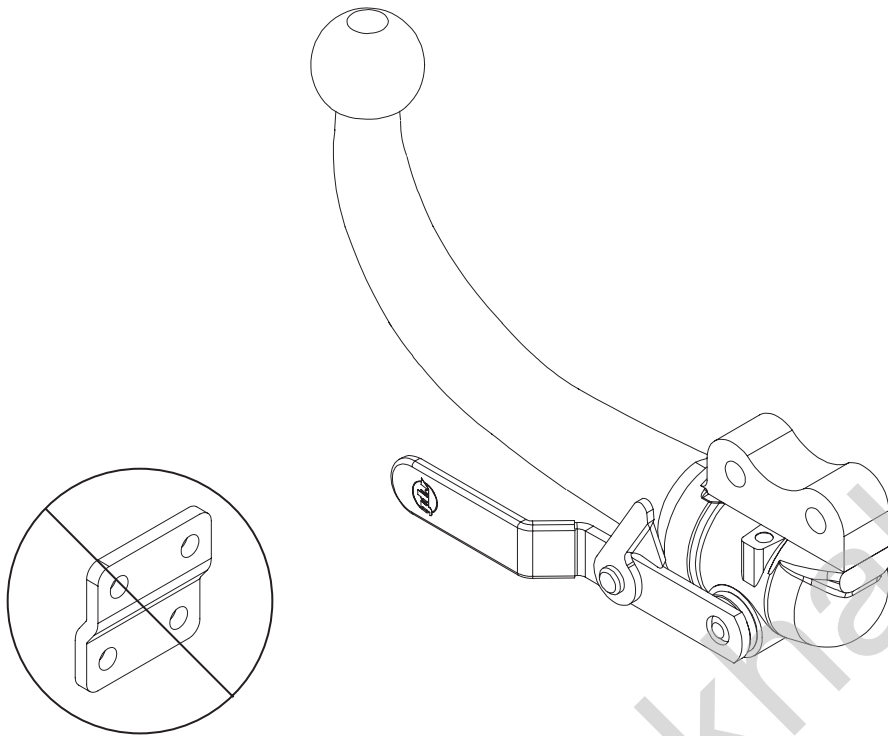

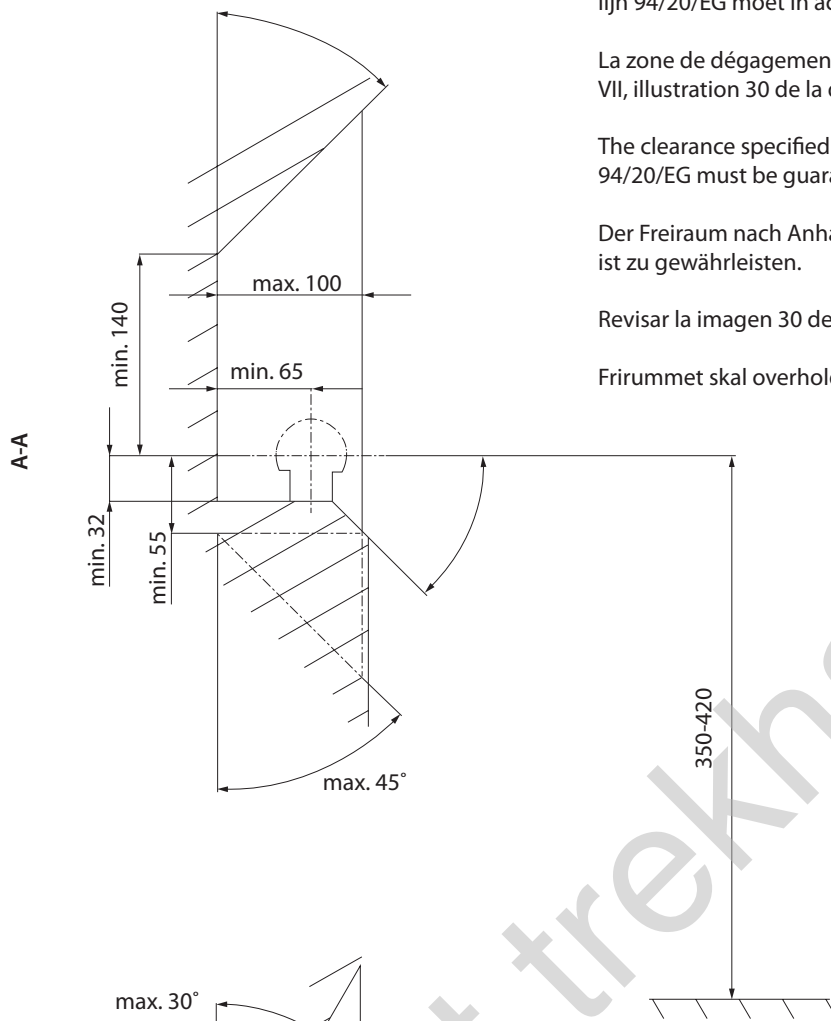

De tussenruimte conform supplement VII, afbeelding 30 van de richtlijn 94/20/EG moet in acht worden genomen.

La zone de dégagement doit être garantie conformément à l'annexe VII, illustration 30 de la directive 94/20/CE.

The clearance specified in appendix VII, diagram 30 of guideline 94/20/EG must be guaranteed.

Der Freiraum nach Anhang VII, Abbildung 30 der Richtlinie 94/20/EG ist zu gewährleisten.

Revisar la imagen 30 del suplemento VII según la directiva 94/20/EG

Frirummet skal overholdes iht. bilag VII, fig. 30 i direktiv 94/20/EF.

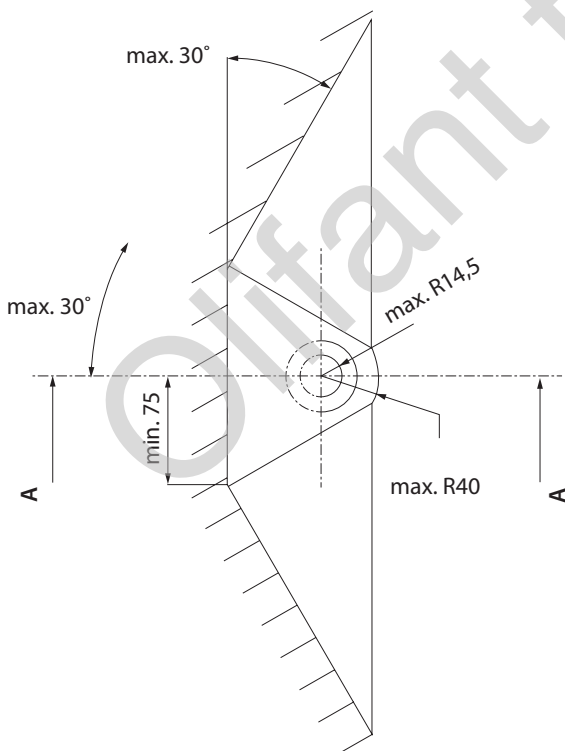

Bij toelaatbaar totaal gewicht van het voertuig

Pour poids total en charge autorisé du véhicule

At laden weight of the vehicle

Bei zulässigem Gesamtgewicht des Fahrzeuges

Peso total admisible del vehículo

Ved tilladt samlet vægt for køretøjet