

Trekhaken - Attelages - Anhängervorrichtungen - Towbars



Mercedes

C-sedan (W204) Kit AMG 2007-... / C-Kombi(W204) Kit AMG 2007-...

C-Coupé (C204) Kit AMG 06/2011-... / E Coupé + Cabrio (A+C207) Kit AMG 2010-...



GDW Ref. 1776T60

EEC APPROVAL N° :

e6*94/20*0821*00

max ↓ kg	X	max ↓ kg			
D=		X 0.00981	≤	10,00	KN
max ↓ kg	+	max ↓ kg			
S/			=	75	Kg
Max.			=	1800	Kg

GDW nv - Hoogmolenwegel 23 - B-8790 Waregem
TEL. 32 (0) 56 60 42 12 (L5) - FAX. 32 (0) 56 60 01 93
 E-Mail : gdw@gdwtowbars.com - Website : www.gdwtowbars.com



Mercedes

C-sedan (W204) Kit AMG 2007-... / C-Kombi(W204) Kit AMG 2007-...

C-Coupé (C204) Kit AMG 06/2011-... / E Coupé + Cabrio (A+C207) Kit AMG 2010-...

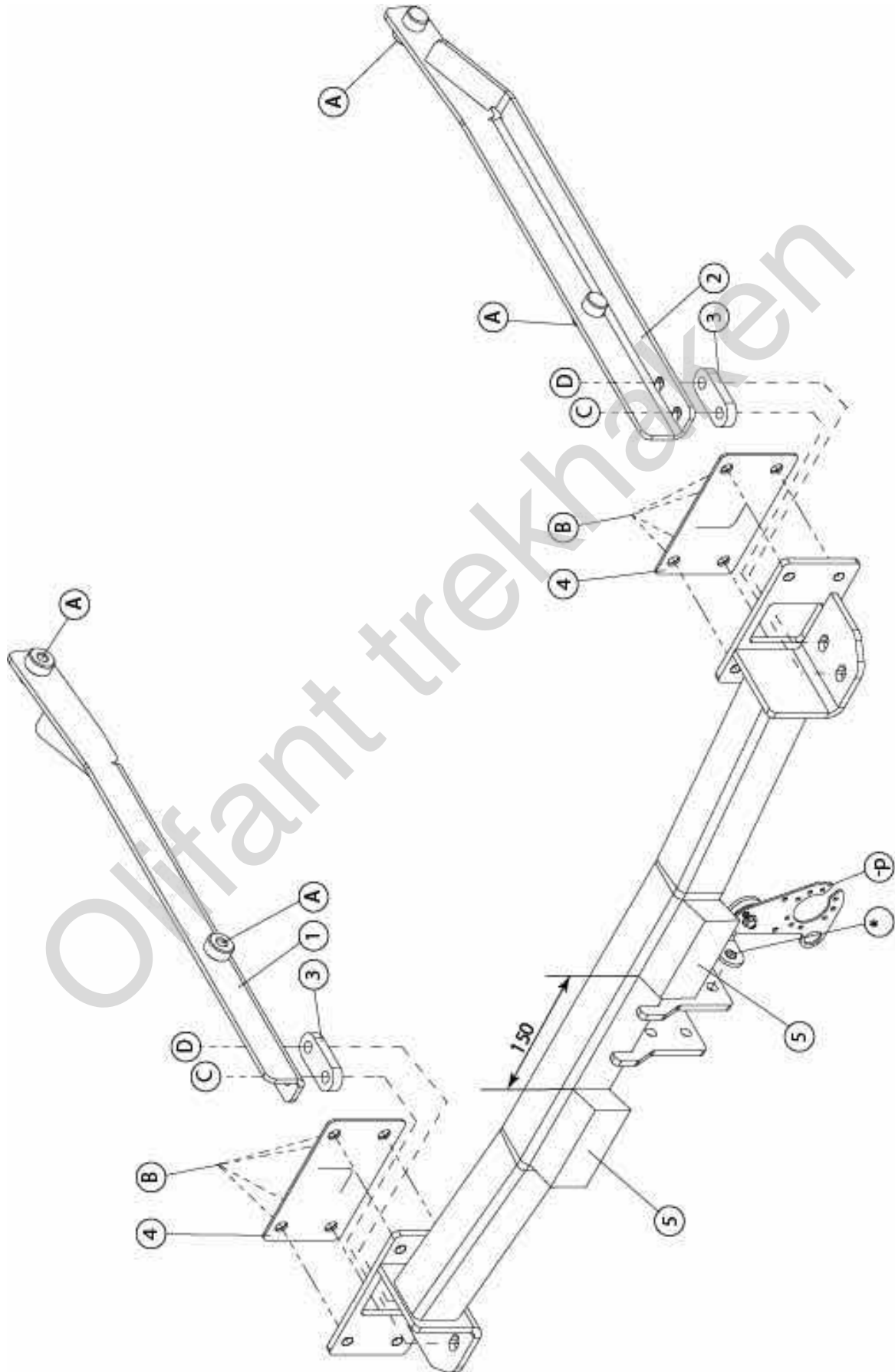



Mercedes

C-sedan (W204) Kit AMG 2007-... / C-Kombi(W204) Kit AMG 2007-...

C-Coupé (C204) Kit AMG 06/2011-... / E Coupé + Cabrio (A+C207) Kit AMG 2010-...

**Fig. 1 = Mercedes C-sedan (W204) AMG 2007-04/2011
Mercedes C-kombi (W204) AMG 2007-04/2011**

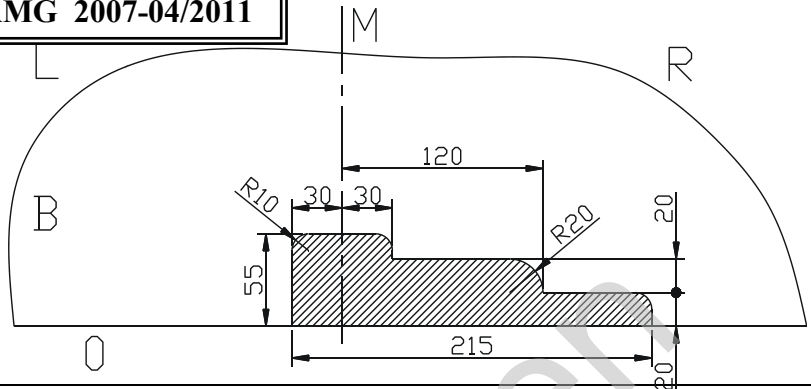

Fig. 2 = Mercedes E Coupé (C207) AMG

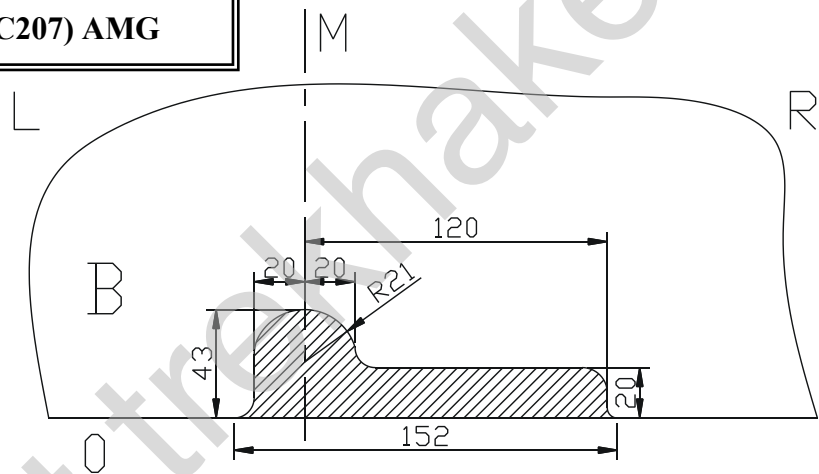
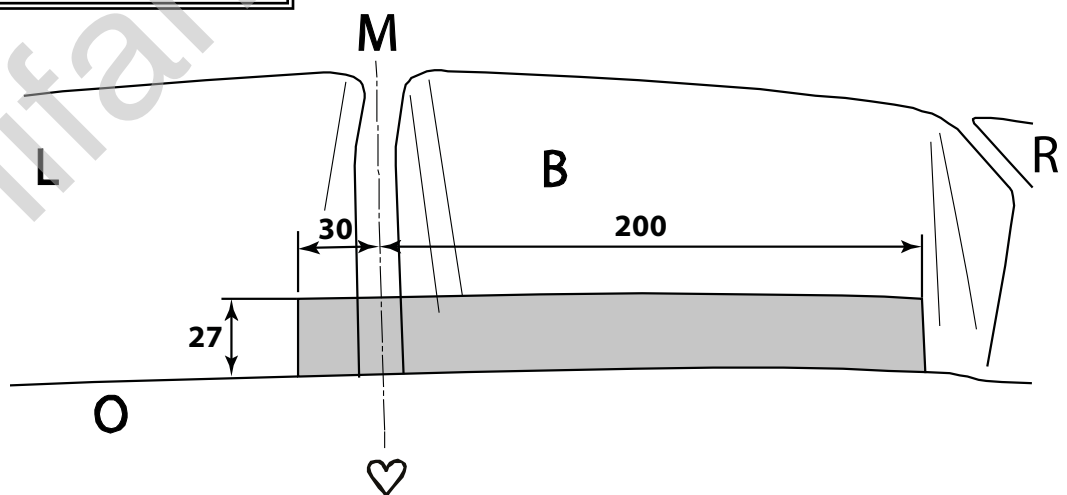

Fig. 3 = Mercedes C Coupé (C204)



Uitsnijding bumper : het gearceerde gebied moet weggesneden worden

“B” = de bumper
“O” = de onderrand van de bumper
“M” = het midden van de bumper

Excision bumper : the hatched area has to be cut away

“B” = the bumper
“O” = the lower rim of the bumper
“M” = the middle of the bumper

Découpe pare-chocs : la zone hachurée doit être découpée

“B” = le pare-chocs
“O” = le bord inférieur du pare-chocs
“M” = le milieu du pare-chocs

Ausschnitt Stoßstange : das schraffierte Gebiet muss weggeschnitten werden

“B” = Stoßstange
“O” = Unterrand Stoßstange
“M” = die Mitte von der Stoßstange



Mercedes

C-sedan (W204) Kit AMG 2007-... / C-Kombi(W204) Kit AMG 2007-...

C-Coupé (C204) Kit AMG 06/2011-... / E Coupé + Cabrio (A+C207) Kit AMG 2010-...

Fig. 4 = Mercedes E Coupé-Cabrio 06/'13-

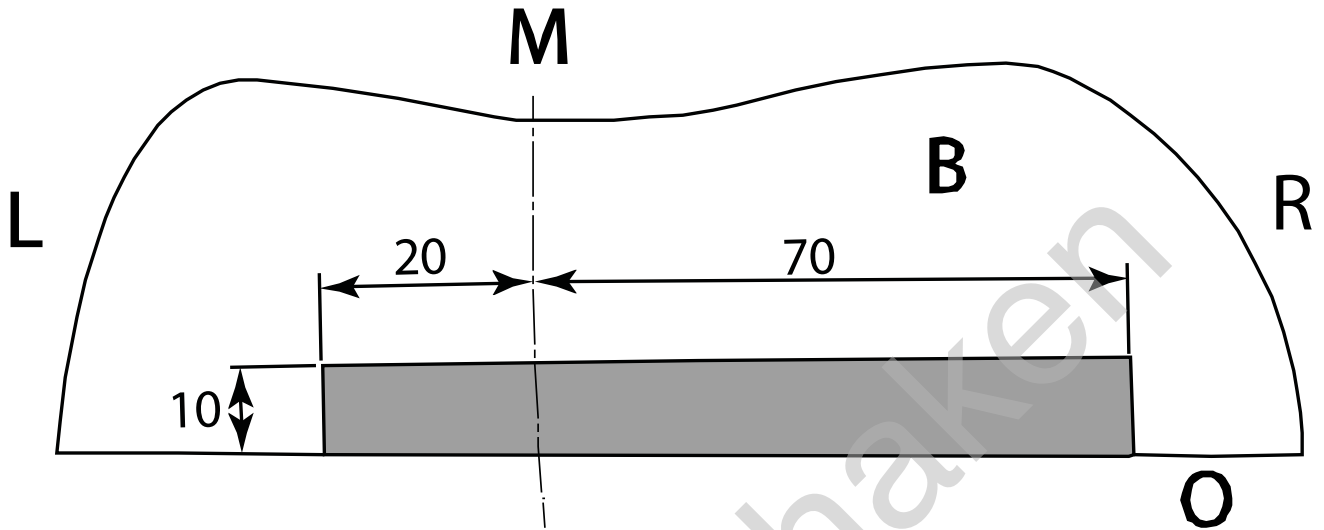
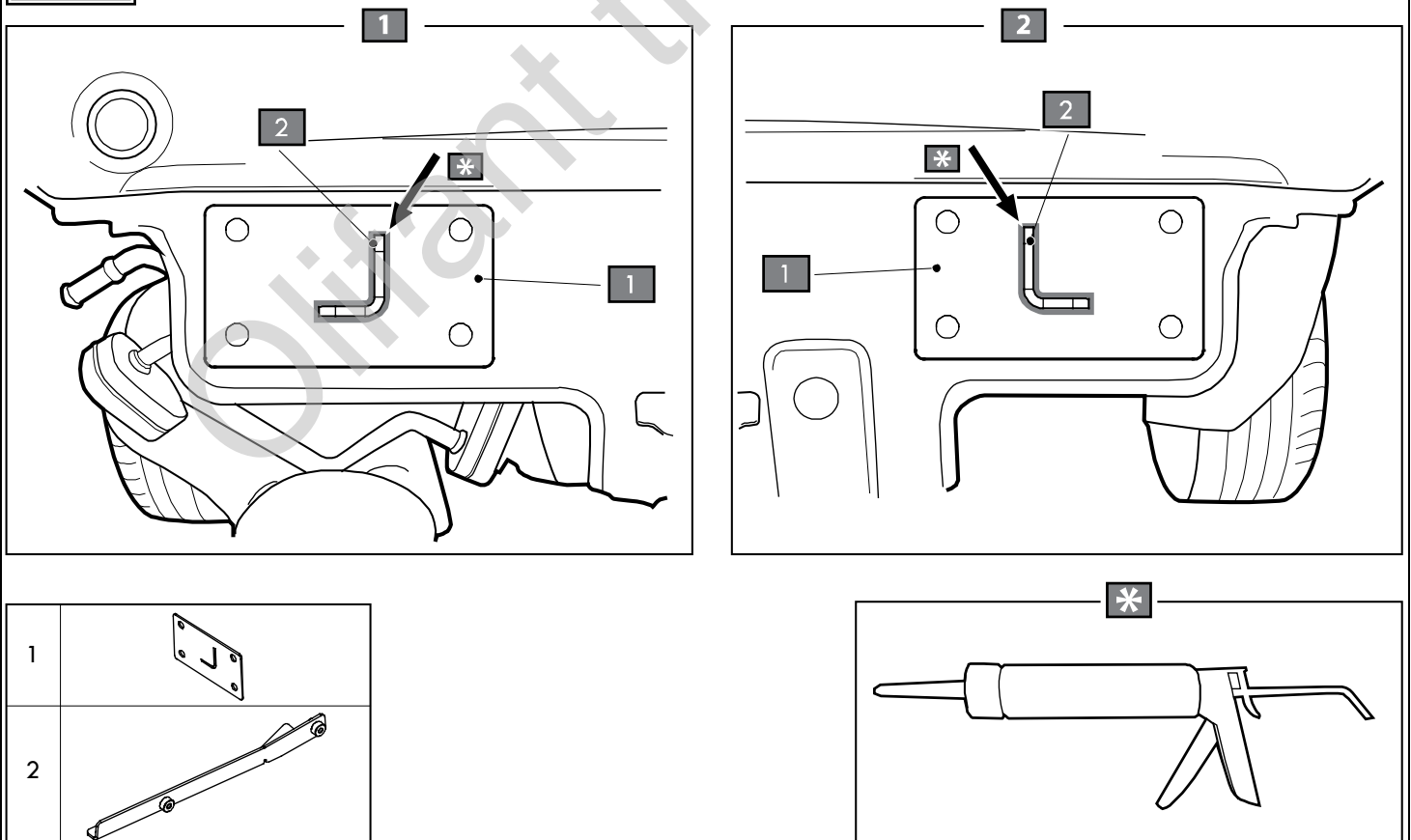

Fig. 5





Mercedes

C-sedan (W204) Kit AMG 2007-... / C-Kombi(W204) Kit AMG 2007-...

C-Coupé (C204) Kit AMG 06/2011-... / E Coupé + Cabrio (A+C207) Kit AMG 2010-...

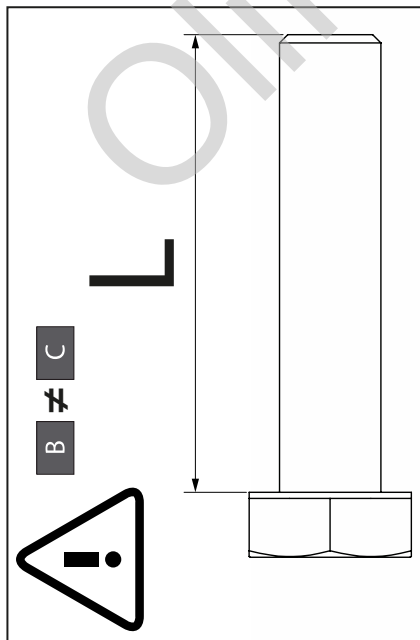
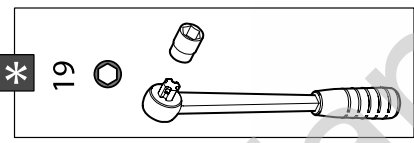
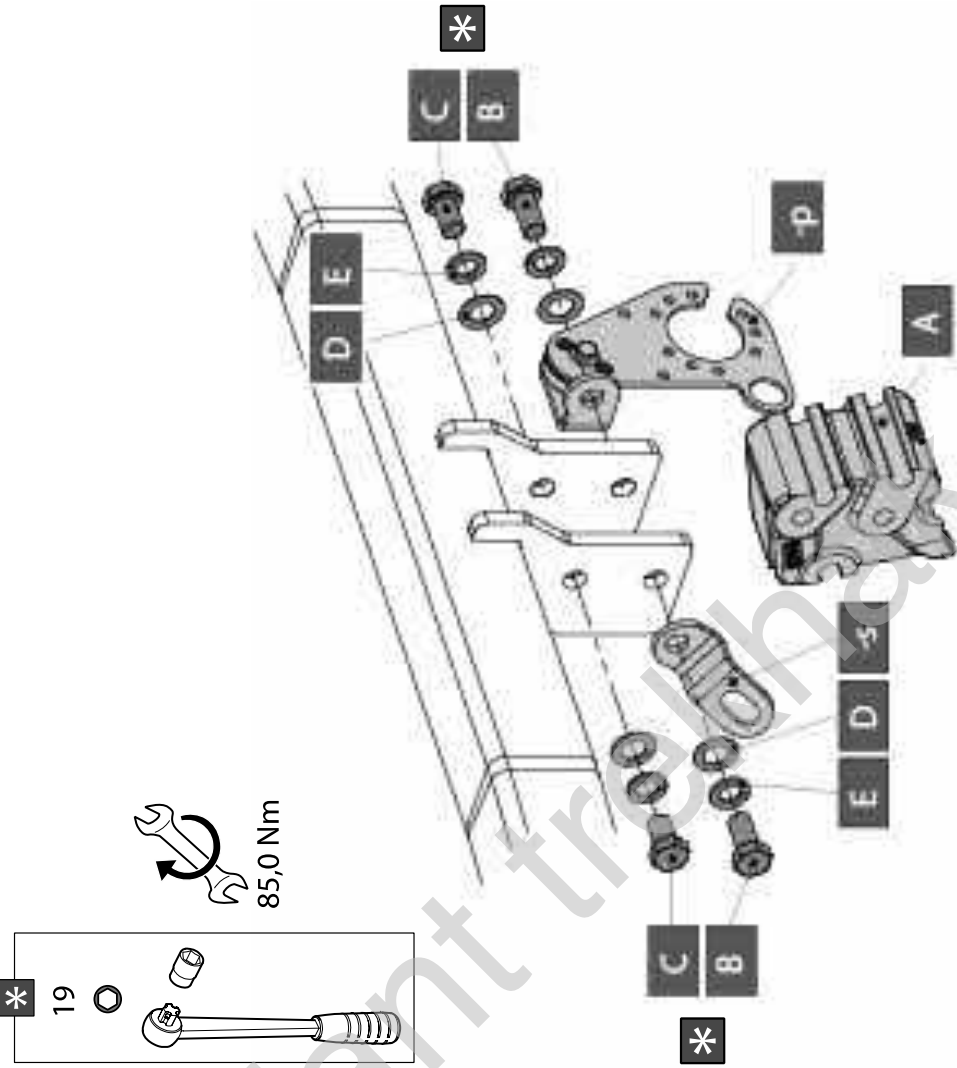

A	X1	GMW REF. 912.003
B	X2	GM933-M12 X 25
C	X2	GM933-M12 X 20
D	X4	Ø 14 X 24 X 1
E	X4	GM128A-M12







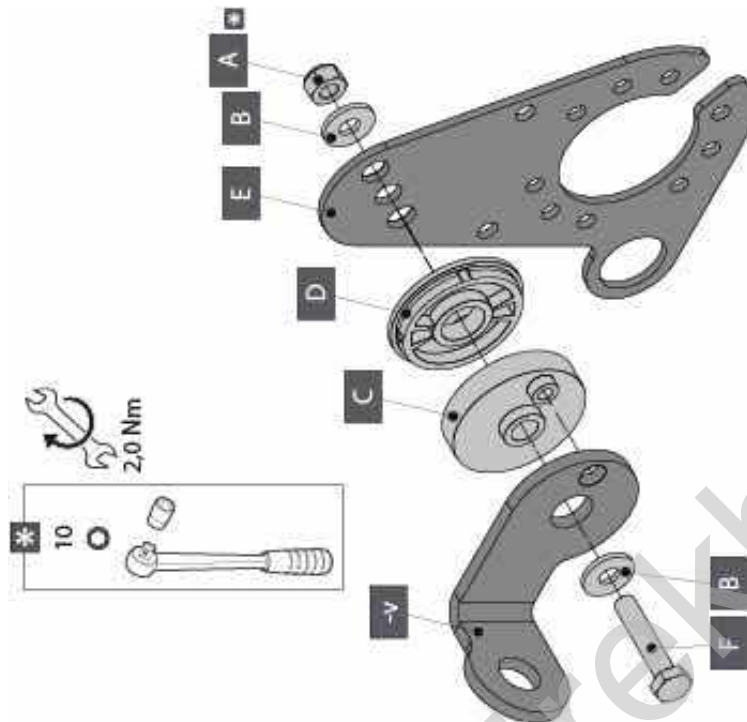

Mercedes

C-sedan (W204) Kit AMG 2007-... / C-Kombi(W204) Kit AMG 2007-...

C-Coupé (C204) Kit AMG 06/2011-... / E Coupé + Cabrio (A+C207) Kit AMG 2010-...

Montage-instructies (P41)



A	X1	DM933-M6	
B	X2	6.3 X 7.5 X 1.6 (NITLON)	
C	X1	GDW REF. 718.16.002	
D	X1	GDW REF. 718.16.003	
E	X1	GDW REF. 908.0914	
F	X1	DM933-M6 X 30	
-V	X1	GDW REF. 908.097	