



GDW
Ref. 1575T36

EEC APPROVAL N° : e6*94/20*0600*00

$D = \frac{\begin{matrix} \text{max} \downarrow \text{kg} \\ \text{car} \end{matrix} \times \begin{matrix} \text{max} \downarrow \text{kg} \\ \text{trailer} \end{matrix}}{\begin{matrix} \text{max} \downarrow \text{kg} \\ \text{car} \end{matrix} + \begin{matrix} \text{max} \downarrow \text{kg} \\ \text{trailer} \end{matrix}}$	$\times 0.00981 \leq 8,00 \text{ KN}$
$s/$	$= 55 \text{ Kg}$
$\text{Max. } \begin{matrix} \text{trailer} \end{matrix}$	$= 1500 \text{ Kg}$

GDW nv - Hoogmolenwegel 23 - B-8790 Waregem
TEL. 32(0)56 60 42 12(L5) - FAX. 32(0)56 60 01 93
 E-Mail : gdw@gdwtowbars.com - Website : www.gdwtowbars.com



Daihatsu Terios

04/2006 -

Ref. 1575T36

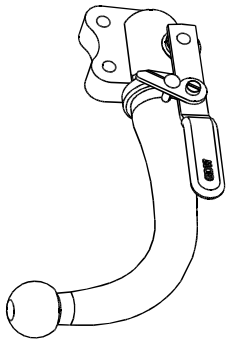

T36 ESCAMOTABLE
GANCIO SFILABILE T 36

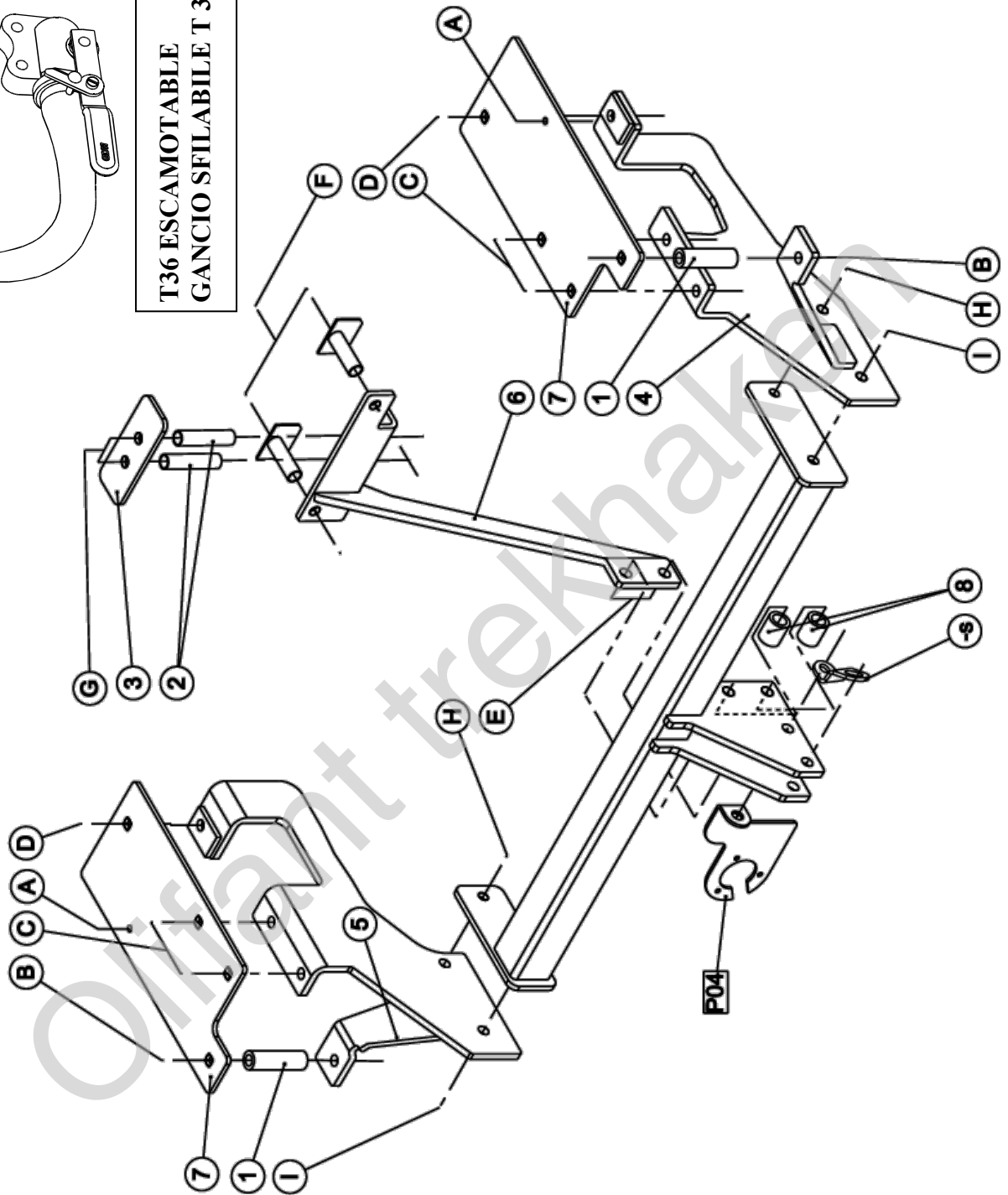







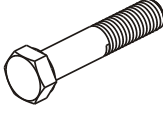
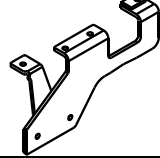

Daihatsu Terios

01/2006 -
Ref. 1575T36

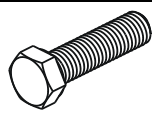
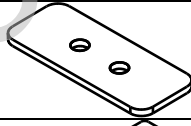
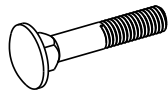
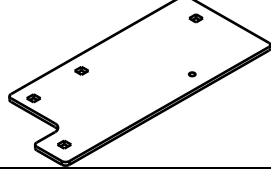
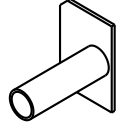
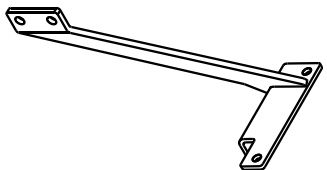
Samenstelling - Composition - Zusammenstellung - Contenido

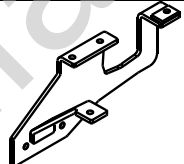
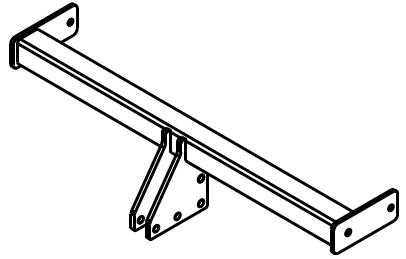
	2 x 2 x 2 x	DIN931 - M12x70 - 8.8 DIN931 - M10x100 - 8.8 DIN931 - M10x80 - 8.8	E G F	GDW Ref. ⑤	1 x	
	14 x 2 x	DIN934 - M10 - 8.8 DIN934 - M12 - 8.8	B-C-D-F-G-H E	GDW Ref. P04	1 x	
	16 x 2 x	DIN128 - A10-FSt DIN128 - A12-FSt	B-C-D-F-G-H-I E	GDW Ref. 112347 ②	2 x	
	4 x	DIN933 - M10x35 - 8.8	H-I	GDW Ref. 112348 ③	1 x	
	2 x 6 x	DIN603 - M10x100 - 8.8 DIN603 - M10x40 - 8.8	B C-D	GDW Ref. 112352 ⑦	2 x	
GDW Ref. 904012	2 x		F	GDW Ref. ⑥	1 x	
GDW Ref. 112346 ①	2 x					
GDW Ref. 112353 ⑧	2 x					
GDW Ref. ④	1 x			GDW Ref. 1575	1 x	

Geleverd met - Livré avec
Delivered with - Geliefert mit

- AFN XXL006
- KIT T36

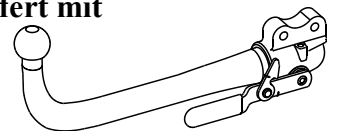

Bouten - Boulons - Bolts - Bolzen			DIN 912 - DIN 931 - DIN 933 - DIN 7991		
Kwaliteit 8.8					
M6 ≙ 10,8Nm of 1,1kgm	M8 ≙ 25,5Nm of 2,60kgm	M10 ≙ 52,0Nm of 5,30kgm			
M12 ≙ 88,3Nm of 9,0kgm	M14 ≙ 137Nm of 14,0kgm	M16 ≙ 211,0Nm of 21,5kgm			
Bouten - Boulons - Bolts - Bolzen			DIN 912 - DIN 931 - DIN 933 - DIN 7991		
Kwaliteit 10.9					
M6 ≙ 13,7Nm of 1,4kgm	M8 ≙ 35,3Nm of 3,6kgm	M10 ≙ 70,6Nm of 7,20kgm			
M12 ≙ 122,6Nm of 12,5kgm	M14 ≙ 194Nm of 19,8kgm	M16 ≙ 299,2Nm of 30,5kgm			



Daihatsu Terios
04/2006 -
Ref. 1575 T36

Foto - photo 1



Foto 2 - photo 2

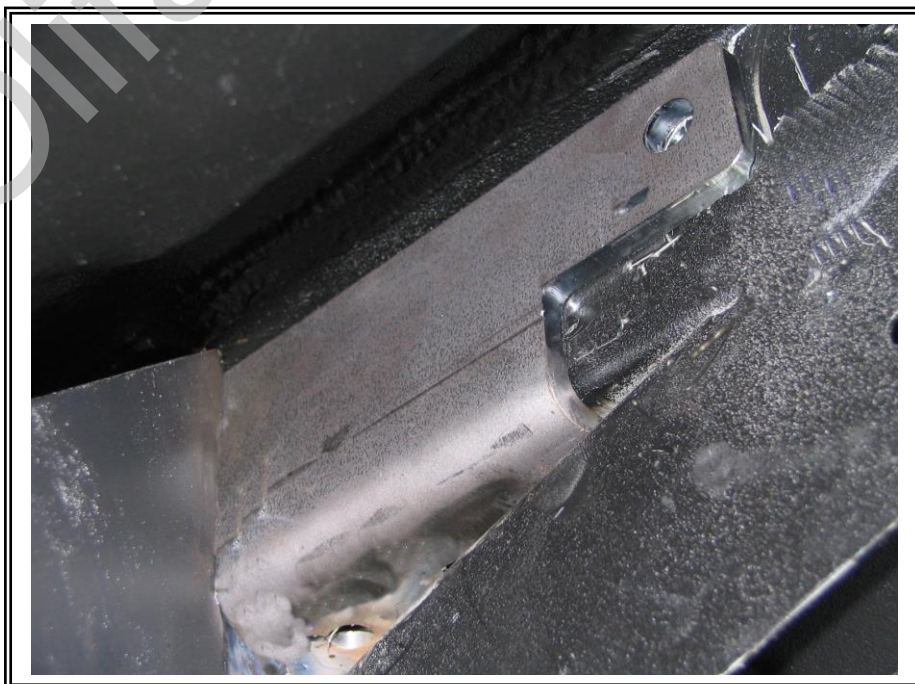



Daihatsu Terios
04/2006 -
Ref. 1575T36

Foto - photo 3



Foto - photo 4

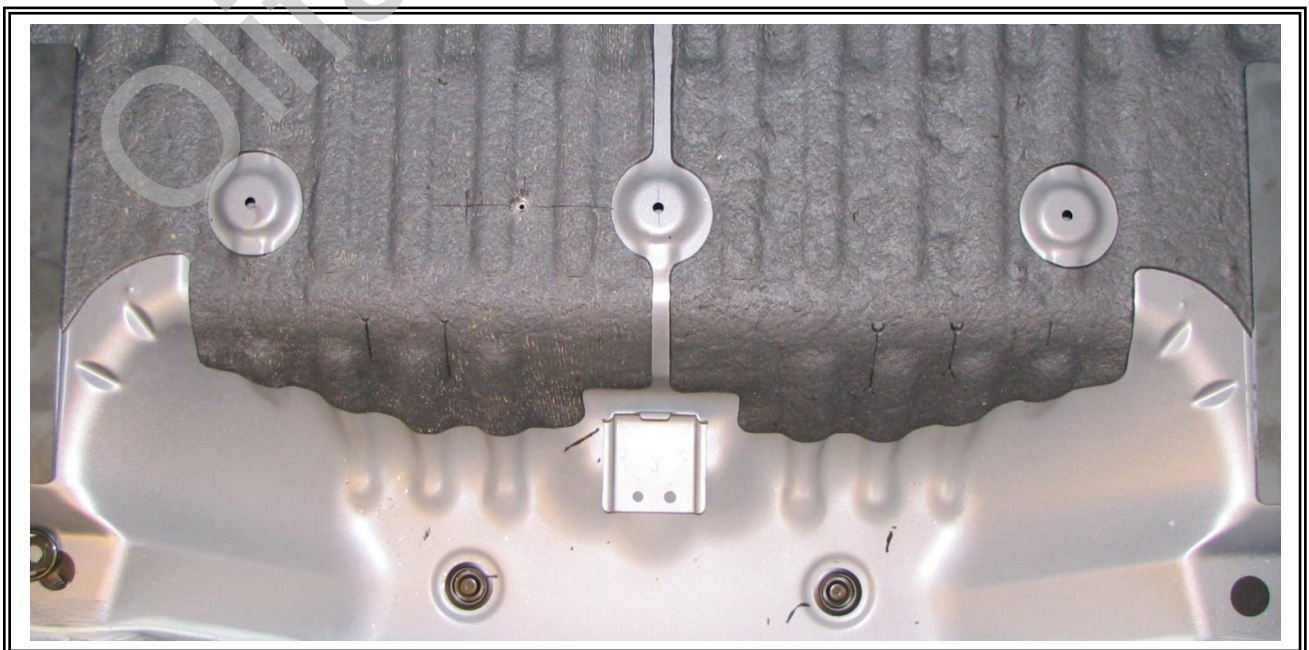



Daihatsu Terios

04/2006 -

Ref. 1575T36

Fig. 1

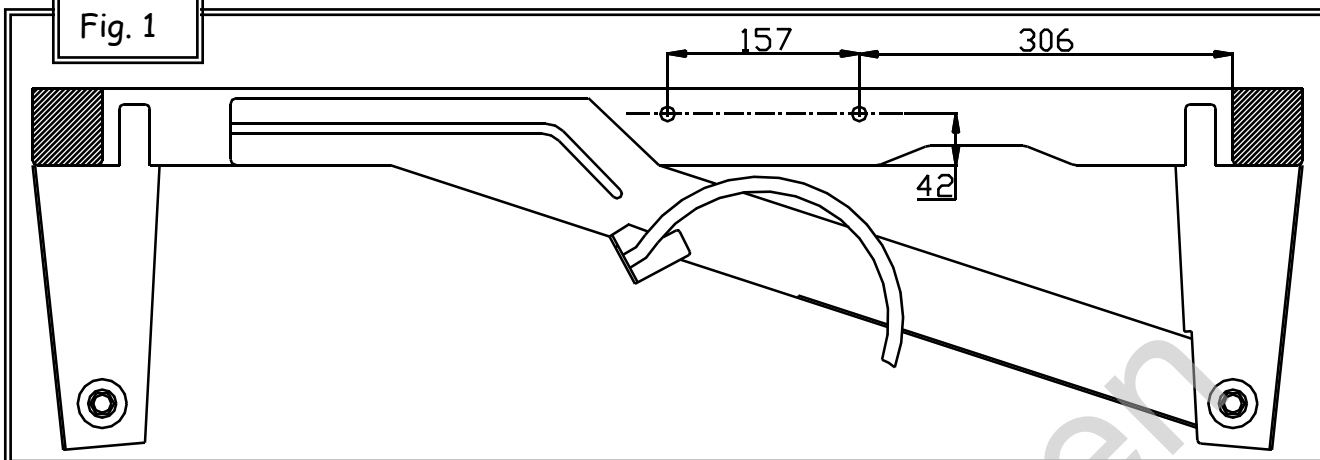

Fig. 2

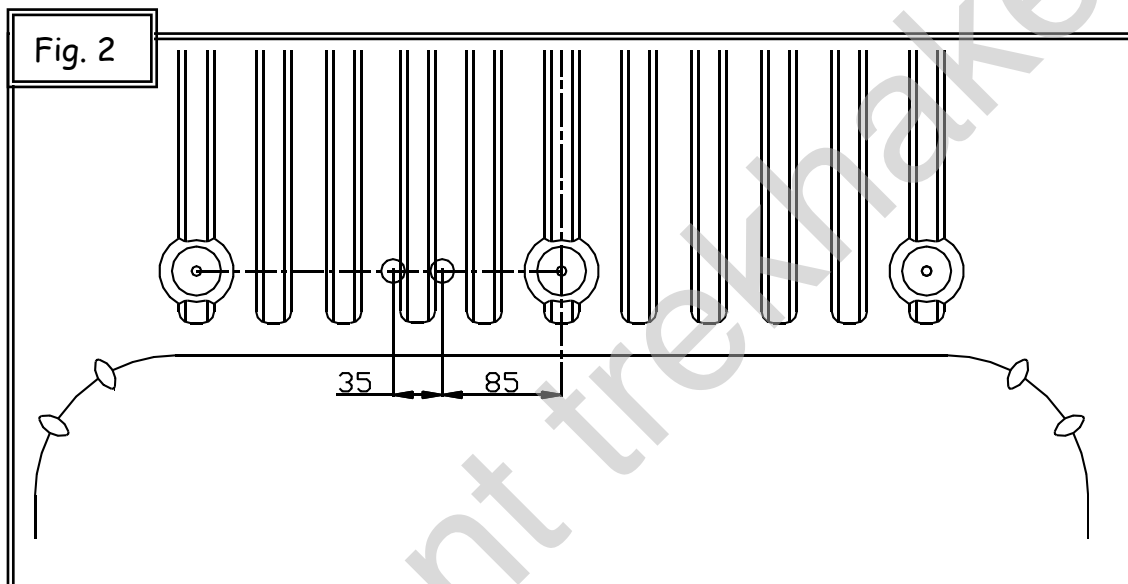
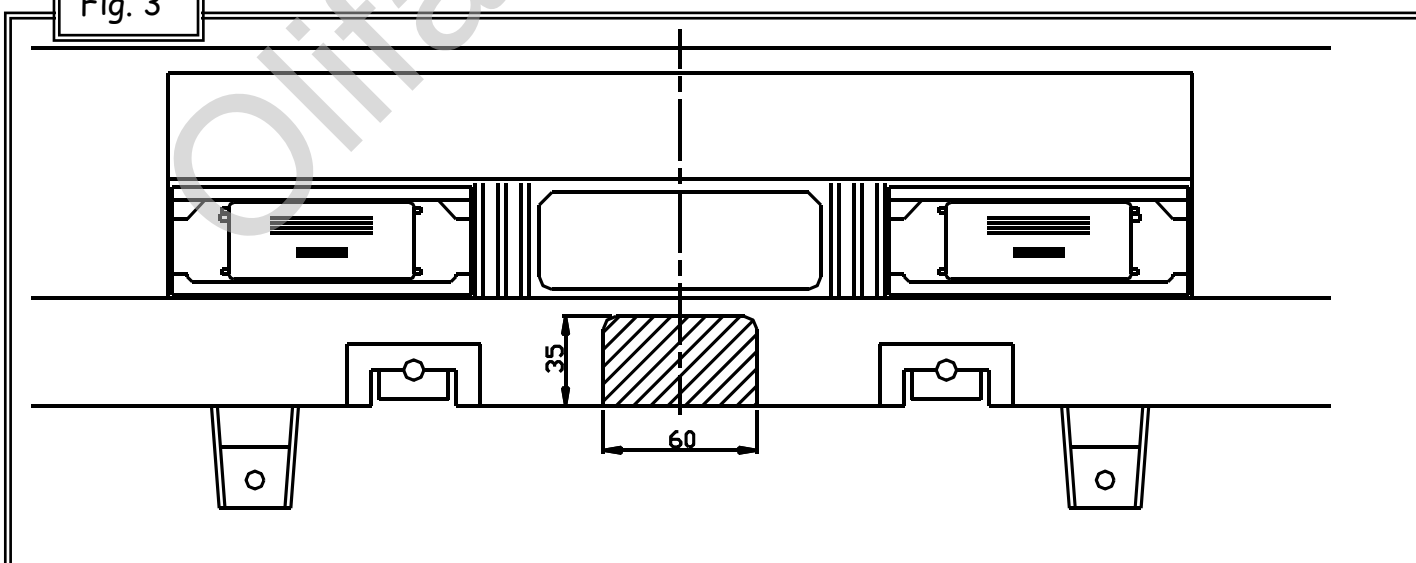

Fig. 3



Uitsnijding bumper : het gearceerde gebied moet weggesneden worden
Découpe pare-chocs : la zone hachurée doit être découpée
Ausschnittung Stoßstange : das schraffierte Gebiet muß weggeschnitten werden
Excision bumper : the hatched area has to be cut away

De tussenruimte conform supplement VII, afbeelding 30 van de richtlijn 94/20/EG moet in acht worden genomen.

La zone de dégagement doit être garantie conformément à l'annexe VII, illustration 30 de la directive 94/20/CE.

The clearance specified in appendix VII, diagram 30 of guideline 94/20/EG must be guaranteed.

Der Freiraum nach Anhang VII, Abbildung 30 der Richtlinie 94/20/EG ist zu gewährl.

La zona libera intorno alla sfera deve essere assicurata conformemente conformemente all'allegato VII, illustrazione 30 della direttiva 94/20/CE.

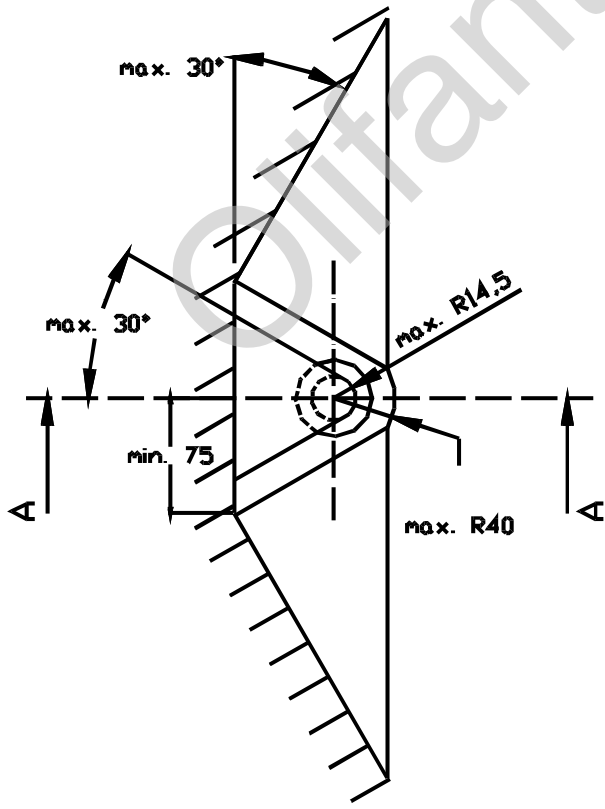
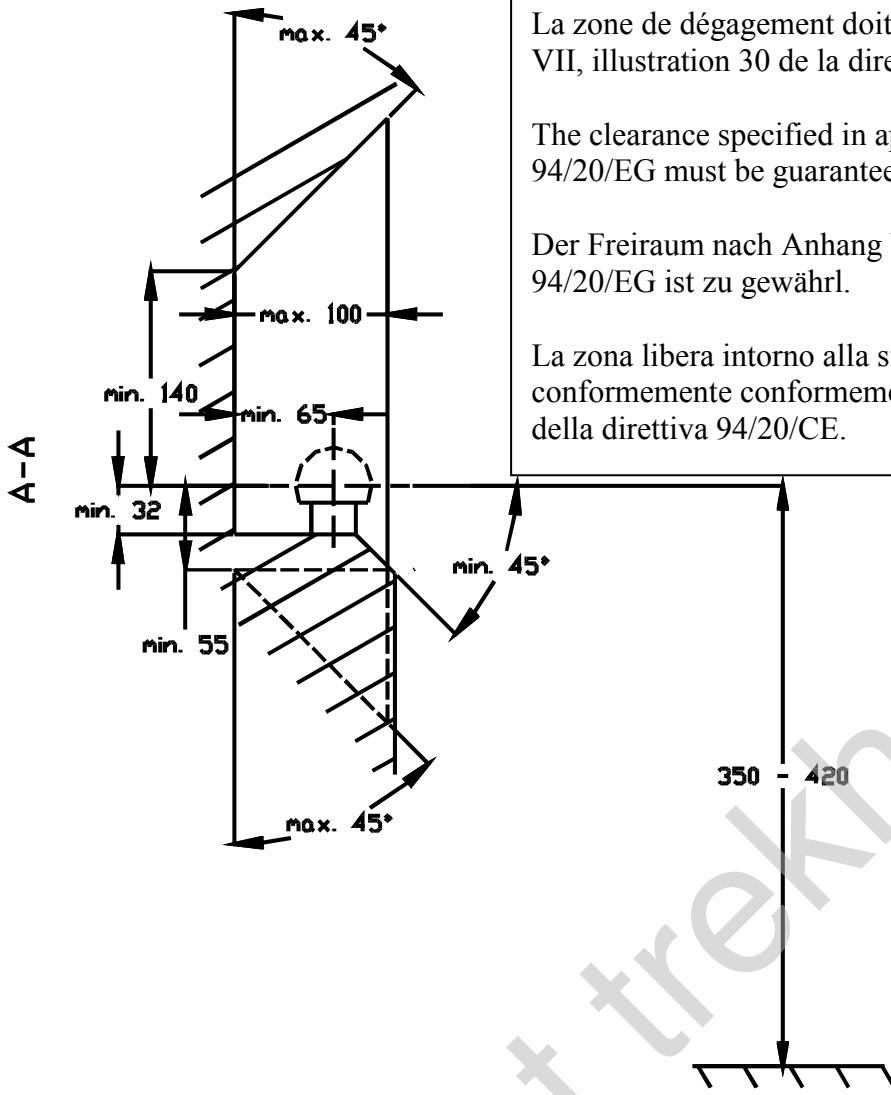

Bij toelaatbaar totaal gewicht van het voertuig

Pour poids total en charge autorisé du véhicule

At laden weight of the vehicle

Bei zulässigem Gesamtgewicht des Fahrzeuges

Per un peso totale di portata autorizzata del veicolo