

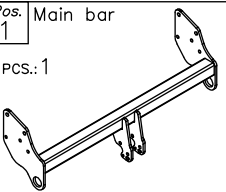

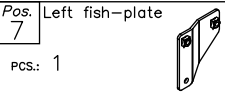

Towing hitch accessories:

Pos. 1 Main bar PCS.: 1 	Pos. 7 Left fish-plate PCS.: 1 	Pos. 14 Bolt 8,8 B M6x50 PCS.: 1 
	Pos. 8 Fish-plate PCS.: 1 	Pos. 15 Plain washer ø12mm PCS.: 16 
Pos. 2 Tow ball (mounting set) PCS.:1 	Pos. 9 Distance sleeve PCS.: 1 	Pos. 16 Plain washer ø10mm PCS.: 2 
Pos. 3 Socket plate PCS.: 1 	Pos. 10 Bolt 8,8 B M12x110mm PCS.: 4 	Pos. 17 Spring washer ø12mm PCS.: 16 
Pos. 4 Right angle bar PCS.: 1 	Pos. 11 Bolt 8,8 B M12x40mm PCS.: 4 	Pos. 18 Spring washer ø10mm PCS.: 2 
Pos. 5 Left angle bar PCS.: 1 	Pos. 12 Bolt 8,8 B M12x1,25x35mm PCS.: 8 	Pos. 19 Nut 8 B M12 PCS.: 4 
Pos. 6 Right fish-plate PCS.: 1 	Pos. 13 Bolt 8,8 B M10x45 PCS.: 2 	Pos. 20 Nut 8 B M10 PCS.: 2 

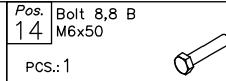
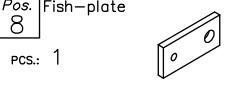
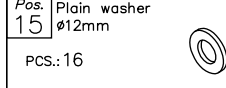
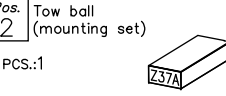
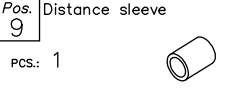
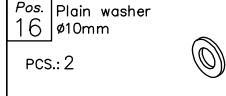
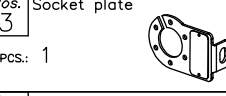
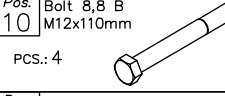
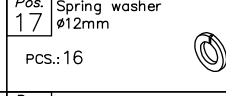
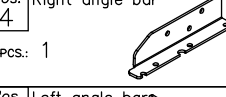
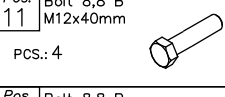

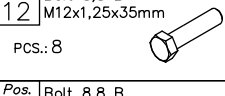
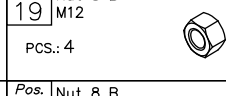
AUTO-HAK Sp. z o. o.

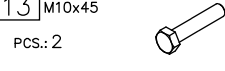
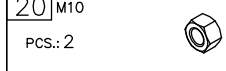
ul. Słoneczna 16K
76-200 SŁUPSK
tel./fax. 59 8 414 414; 59 8 414 413
E-mail: office@autohak.com.pl
www.autohak.com.pl

Towing hitch (without electrical set)

Class: **A50-X** Cat. no. **Z37A**

Designed for:

Manufacturer: **MITSUBISHI**

Model: **PAJERO, MONTERO**

Type: **5 doors**

produced since 03.2007

Technical data:

D-value: 15,8 kN

maximum trailer weight: **3300 kg**

maximum vertical cup load: **135 kg**

Approval number according to Directive 94/20/EC: **e20*94/20*1038*00**

Foreword

This towing hitch is designed according to rules of safety traffic regulations. The towing hitch is a safety component and can be install only by qualified personnel. Any alteration or conversion of the towing hitch is prohibited and would lead to cancellation of design certification. Remove insulating compound and underseal from vehicle (if present) in the area of the matting surfaces of the towing hitch.

The vehicle manufacturer's specifications regarding trailer load and max. vertical cup load are decisive for driving whereat values for the towing hitch cannot be exceeded.

D-value formula:

$$\frac{\text{Max trailer weight [kg]} \times \text{Max vehicle weight [kg]}}{\text{Max trailer weight [kg]} + \text{Max vehicle weight [kg]}} \times \frac{9,81}{1000} = D \text{ [kN]}$$

FITTING INSTRUCTION

Clamp mark in acc. with		Cables joining
ISO	PN	
1	L	Left directional lights
2	+	Rear fog lights
3	31	Ground
4	R	Right directional lights
5	58R	Right side parking lights
6	54	Stoptlights
7	58L	Left side parking lights

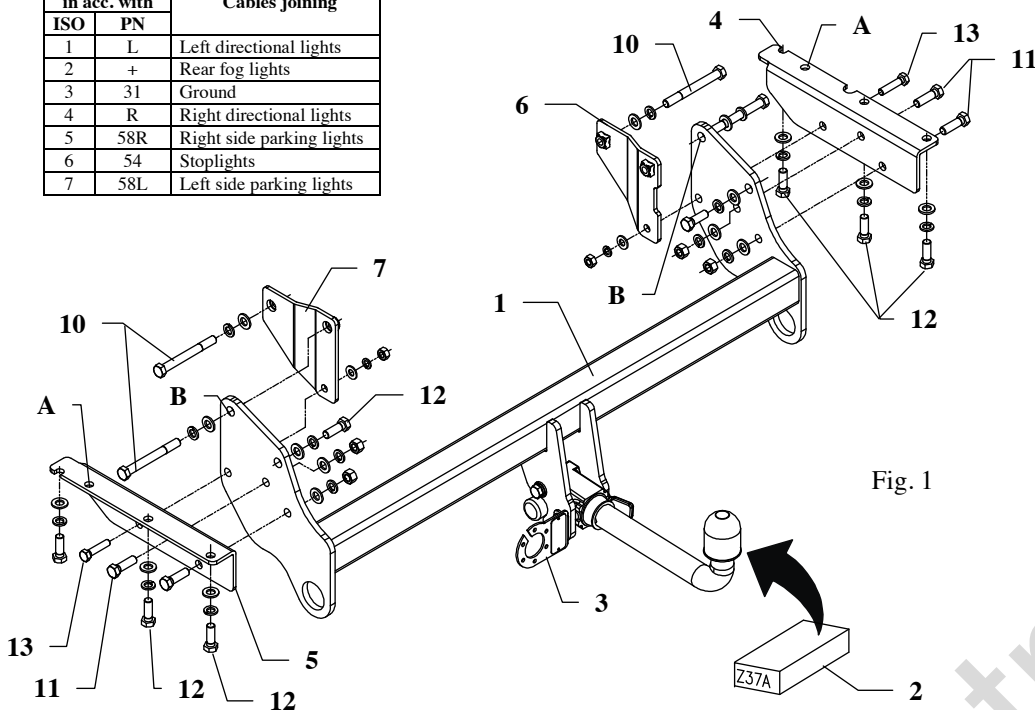

Fig. 1

This towing hitch is designed to assembly in following cars:
MITSUBISHI PAJERO, MONTERO, 5 doors, produced since 03.2007,
 catalogue no. **Z37A** and is prepared to tow trailers max total weight
3300 kg and max vertical load **135 kg**.

Torque settings for nuts and bolts (8,8):	
M 8 - 25 Nm	M 10 - 55 Nm
M 12 - 85 Nm	M 14 - 135 Nm

From manufacturer

Thank you for buying our product. Their reliability has been confirmed in many tests. Reliability of towing hitch depends also on correct assembly and right operation. For this reasons we kindly ask to read carefully this instruction and apply to hints.

The towing hitch should be install in points described by a car producer.

The instruction of the assembly

1. Disassemble mud covers and original bar with tow eyes (this unit will be not used any more).
2. In long version with air-conditioning disassemble a filter (fig. 2).
3. Put angle bar (pos. 4 and 5) below the car to chassis members in this way so holes in angle bar agree with holes in members and fix by bolts M12x1,25x35mm (pos. 12), see fig.1. **NOTE!** In short version the last bolt fix through hole A of angle bar.
4. Between mounted angle bar put main bar of the towing hitch (pos. 1) and fix by bolts M12x40mm (pos. 11) and:
 - **long body version** – put bend fish-plates (pos. 6 and 7) and fix all using bolts M12x110mm (pos. 10) and M10x45mm (pos. 13)
 - **short body version**- through holes B fix main bar to the chassis members by bolts M12x110mm (one each side, bend fish-plates pos. 6 and 7 not used)
5. Fix body of the automat and place tow-ball according to supplied instruction. Note! Remember to place socket plate (pos. 3) as shown on the drawing 1.
6. In long version with air-conditioning reassemble a filter (see fig. 2).
7. Reassemble mud covers and tighten all bolts according to the torque shown in the table.
8. Connect electric wires of 7-poles socket according to the instruction of the car. (Recommend to make at authorized service station).
9. Complete paint layer damaged during installation.

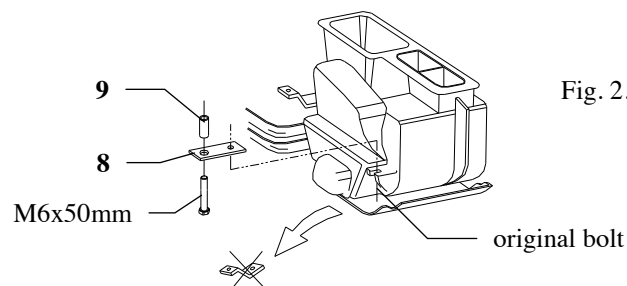

Fig. 2. Filter installation

NOTE

After installation of the towing hitch you should get adequate note in registration book (at authorised service station).The car should be equipped with:

- Indicators
- Tow mirrors

After 1000km check all bolts and nuts. The ball of towing hitch must be always kept clear and conserve with a grease.