

## FITTING INSTRUCTION

Clamp mark in acc. with		Cables joining
ISO	PN	
1	L	Left directional lights
2	+	Rear fog lights
3	31	Ground
4	R	Right directional lights
5	58R	Right side parking lights
6	54	Stoplights
7	58L	Left side parking lights

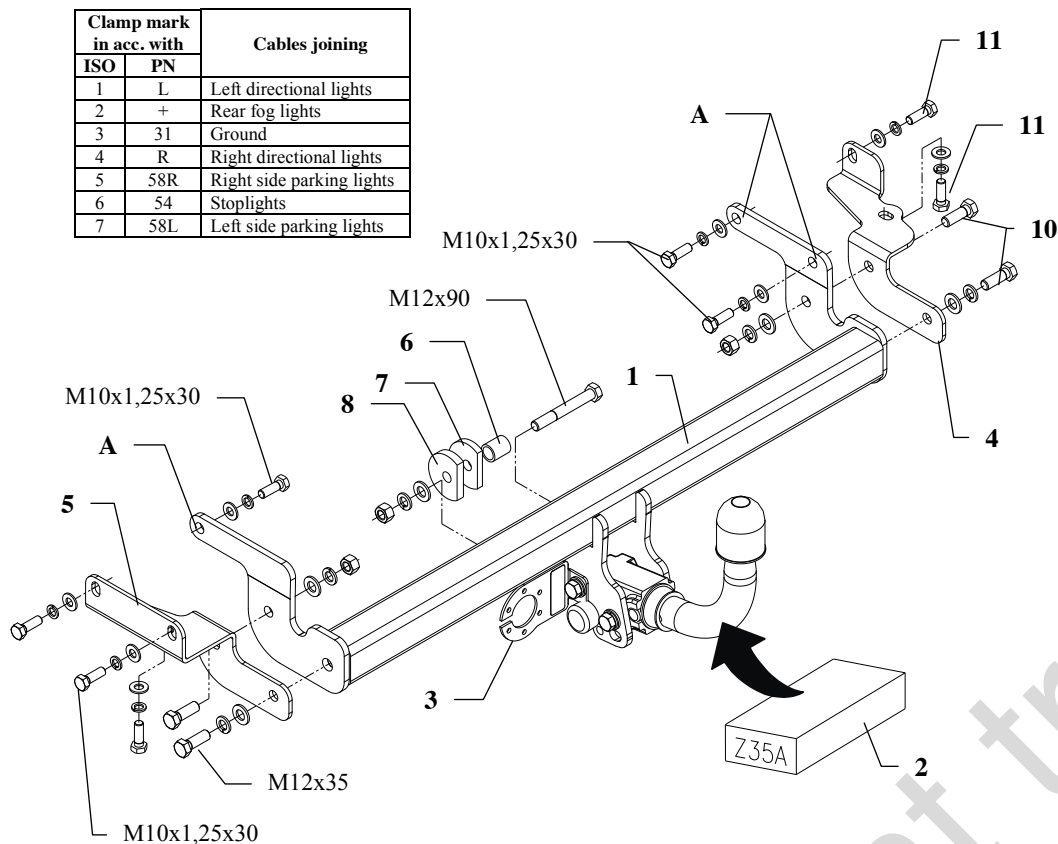

This towbar is designed to assembly in following cars:  
**MITSUBISHI LANCER 4 doors (JT41)**, produced since 09.2003 till 01.2008, catalogue no. **Z35A** and is prepared to tow trailers max total weight **1200 kg** and max vertical load **60 kg**.

### From manufacturer

Thank you for buying our product. Their reliability has been confirmed in many tests. Reliability of towbar depends also on correct assembly and right operation. For this reasons we kindly ask to read carefully this instruction and apply to hints.

*The towbar should be install in points described by a car producer.*

## The instruction of the assembly

1. Cut out the lower fragment of the bumper, as shown on the fig. 2.
2. Put main bar of the towbar to the car frame in that way so holes (pos. A) be covered with holes in frame and fix using bolts M10x1,25x30 mm (pos. 11) - fix loosely.
3. To the left chassis member put element (pos. 5) and fix using bolts M10x1,25x30mm (pos. 11) and M12x35mm (pos. 10) – see figure 1.
4. To the right chassis member put element (pos. 4) and fix using bolts M10x1,25x30mm (pos. 11) and M12x35mm (pos. 10) – see figure 1.
5. Through hole (pos. B) of the towbar fix with original towing eye – use truncate washers (pos. 7 and 8), distance sleeve  $\varnothing 21\text{mm}$ ,  $L=25\text{mm}$  (pos. 6) and bolt M12x90mm (pos. 9) – see figure 3.
6. Fix body of the automat and place tow-ball according to supplied instruction. Note! Remember to place socket plate (pos. 3) as shown on the drawing 1.
7. Tighten all bolts according to the torque shown in the table.
8. Connect electric wires of 7-poles socket according to the instruction of the car. (Recommend to make at authorized service station).
9. Complete paint layer damaged during installation.

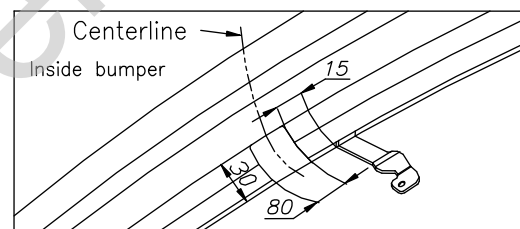

Fig. 2. Bumper cut out

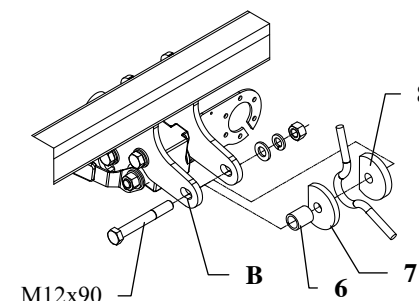

Fig. 3. Rear view

### Torque settings for nuts and bolts (8,8):

<b>M6</b> - 11 Nm	<b>M8</b> - 25 Nm	<b>M10</b> - 50 Nm
<b>M12</b> - 87 Nm	<b>M14</b> - 138 Nm	<b>M16</b> - 210 Nm





### NOTE

After install the towbar you should get adequate note in registration book (at authorised service station). The car should be equipped with:

- Indicators
- Tow mirrors

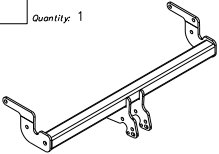
After 1000km of exploitation check all bolts and nuts. The ball of towbar must be always kept clear and conserve with a grease.

## Towbar accessories:

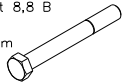
Pos. 1 Name: Main bar Quantity: 1	Pos. 5 Name: Left handle Quantity: 1	Pos. 10 Name: Bolt 8,8 B Quantity: 4 Dim.: M12x35mm	Pos. 15 Name: Spring washer Quantity: 5 Dim.: Ø 12,2 mm
	Pos. 6 Name: Distance sleeve Quantity: 1 Dim.: Ø21x2,65mm L=25mm	Pos. 11 Name: Bolt 8,8 B Quantity: 8 Dim.: M10x1,25x30mm	Pos. 16 Name: Spring washer Quantity: 8 Dim.: Ø 10,2 mm
Pos. 2 Name: Tow ball Quantity: 1	Pos. 7 Name: Truncate washer Quantity: 1 Dim.: Ø58xØ13x8mm	Pos. 12 Name: Nut 8 B Quantity: 3 Dim.: M12	
	Pos. 8 Name: Truncate washer Quantity: 1 Dim.: Ø58xØ13x10mm	Pos. 13 Name: Plain washer Quantity: 5 Dim.: Ø 13 mm	
Pos. 3 Name: Socket plate Quantity: 1		Pos. 14 Name: Plain washer Quantity: 8 Dim.: Ø 10,5 mm	
Pos. 4 Name: Right handle Quantity: 1	Pos. 9 Name: Bolt 8,8 B Quantity: 1 Dim.: M12x90mm		
			



## PPUH AUTO-HAK S.J.

Produkcja Zaczepów Kulowych  
Henryk & Zbigniew Nejman  
76-200 SŁUPSK ul. Słoneczna 16K  
tel/fax (059) 8-414-414; 8-414-413  
E-mail: [office@autohak.com.pl](mailto:office@autohak.com.pl)  
[www.autohak.com.pl](http://www.autohak.com.pl)

### Towing hitch (without electrical set)

Class: **A50-X** Cat. no. **Z35A**

Designed for:

Manufacturer: **MITSUBISHI**

Model: **LANCER**

Type: **4 doors (JT41)**

produced since 09.2003 till 01.2008

Technical data:

**D-value: 6,2 kN**

maximum trailer weight: **1200 kg**

maximum vertical cup load: **60 kg**

Approval number according to Directive 94/20/EC: **e20\*94/20\*0125\*00**

### Foreword

This towbar is designed according to rules of safety traffic regulations. The towing hitch is a safety component and can be install only by qualified personnel. Any alteration or conversion of the towing hitch is prohibited and would lead to cancellation of design certification. Remove insulating compound and underseal from vehicle (if present) in the area of the matting surfaces of the towing hitch. The vehicle manufacturer's specifications regarding trailer load and max. vertical cup load are decisive for driving whereat values for the towing hitch cannot be exceeded.

*D-value formula:*

$$\frac{\text{Max trailer weight [kg]} \times \text{Max vehicle weight [kg]}}{\text{Max trailer weight [kg]} + \text{Max vehicle weight [kg]}} \times \frac{9,81}{1000} = D \text{ [kN]}$$