

PPUH AUTO-HAK Sp.J.

Henryk & Zbigniew Nejman
ul. Słoneczna 16K 76-200 SŁUPSK
POLAND

tel/fax +48 059 8-414-414; 8-414-413

e-mail: office@autohak.com.pl

www.autohak.com.pl



AUTO-HAK



**mitsubishi LANCER
KOMBI (JT45, CS3)**

Cat. no:

Z30A



09.2003 → 08.2008

e20

e20*94/20*1037*00



1,5h

D

7,12 kN

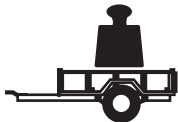

R=1200 kg



S=60 kg



17,3 kg

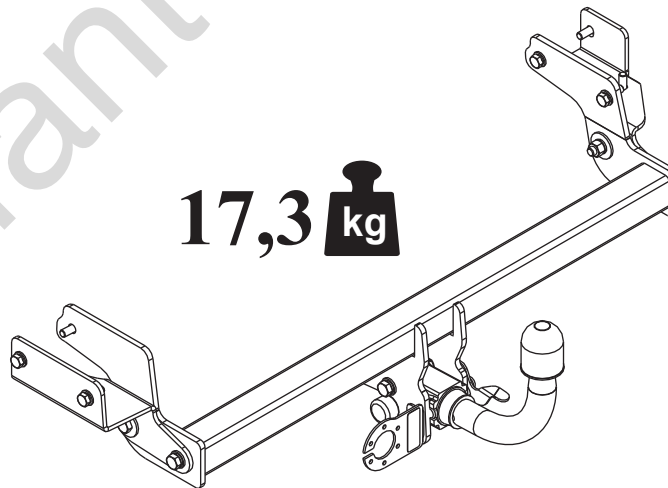

**M6 - 11 Nm
M10 - 50 Nm
M14 - 138 Nm**

**M8 - 25 Nm
M12 - 87 Nm
M16 - 210 Nm**









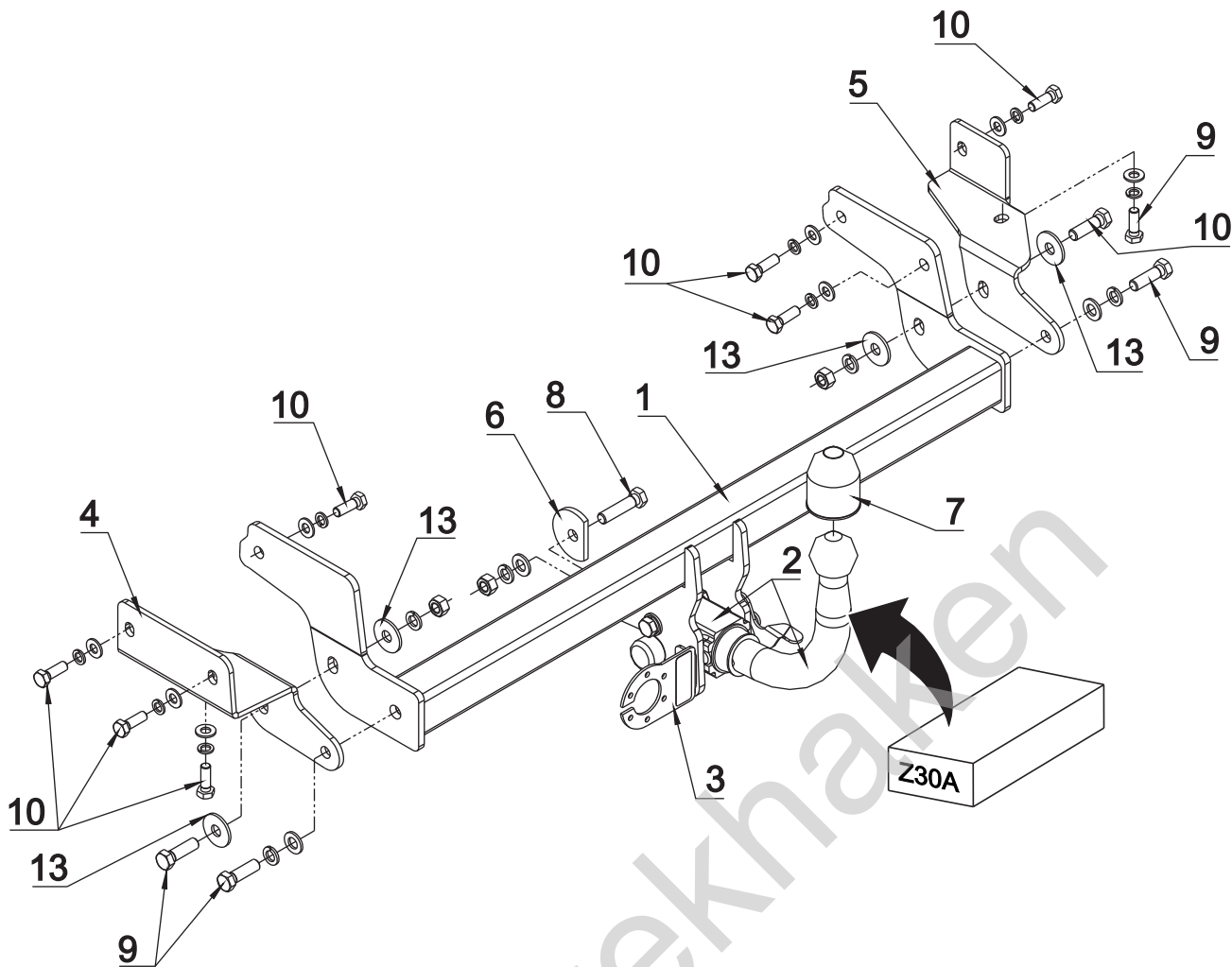

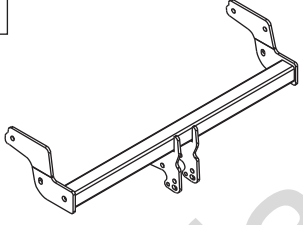

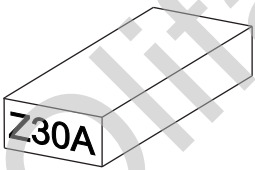
0 km →

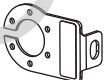

1000 km





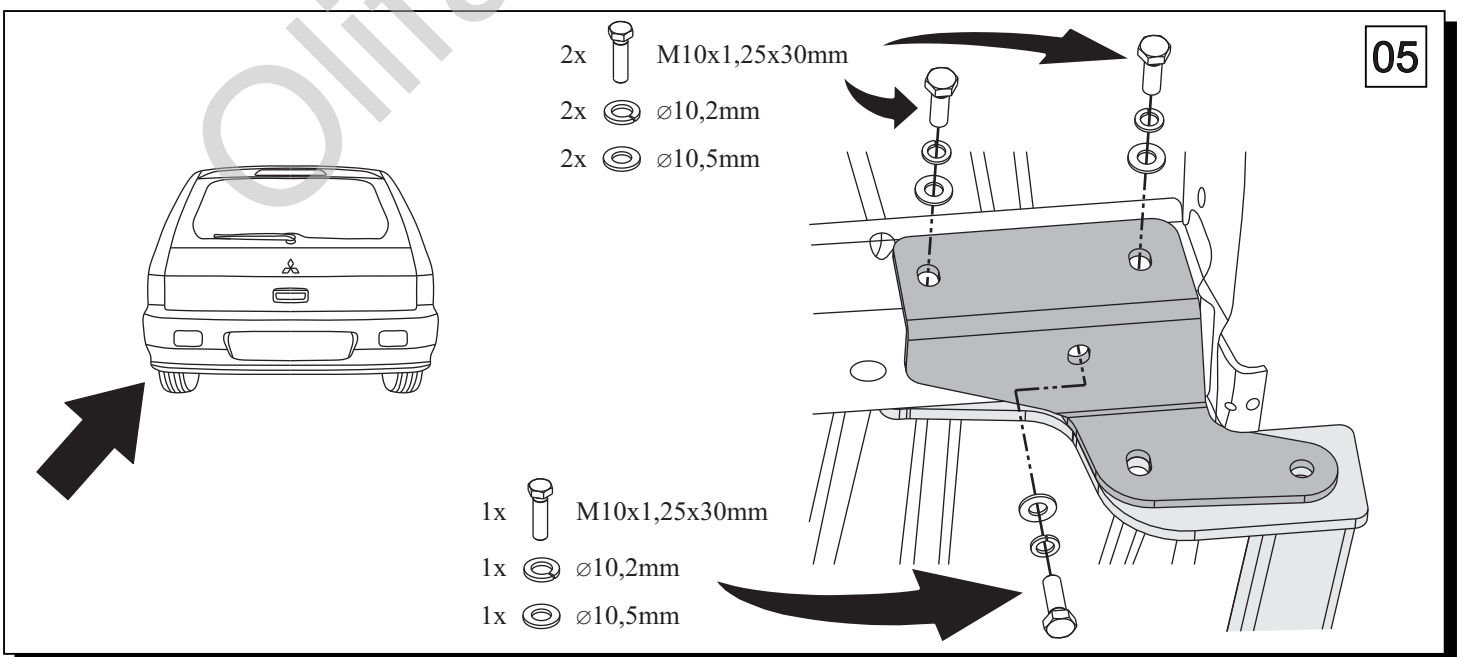
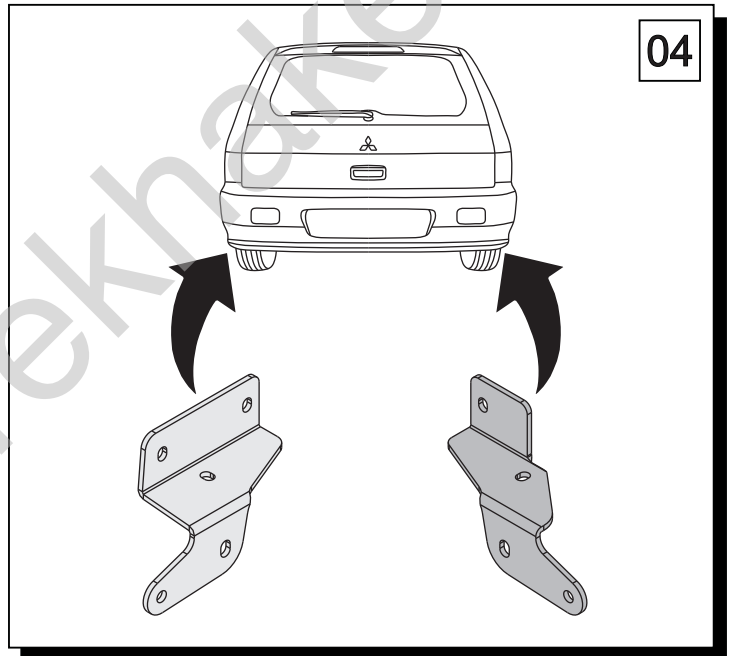
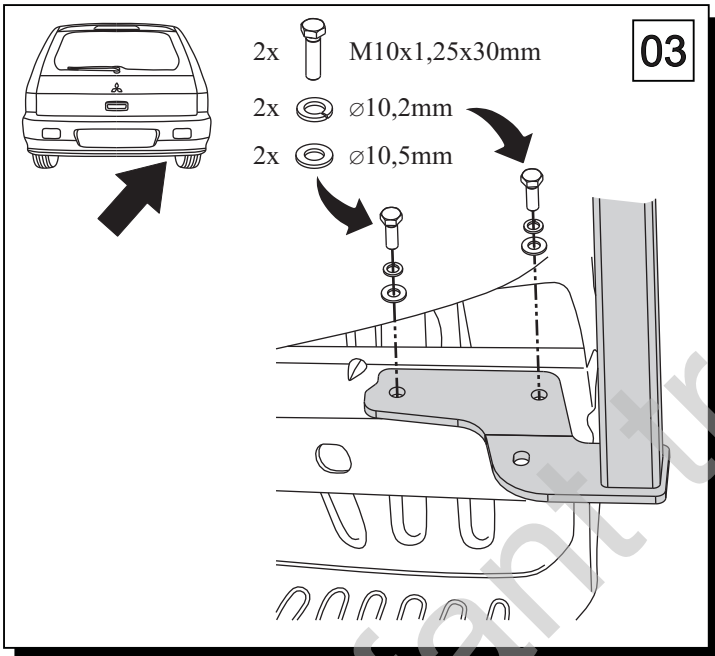
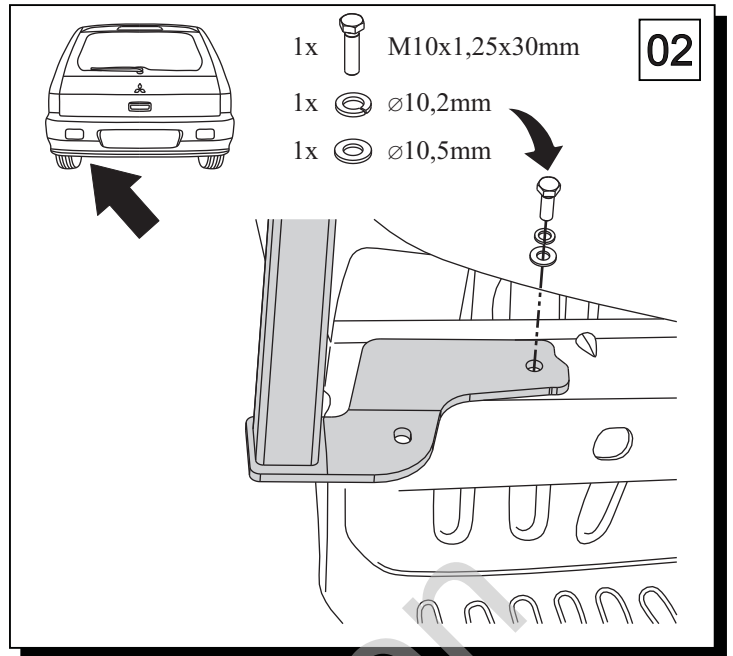
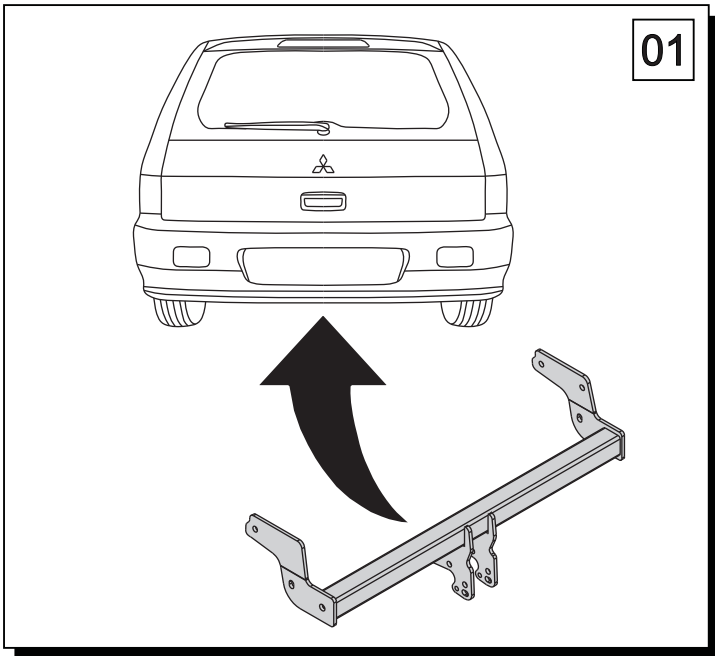

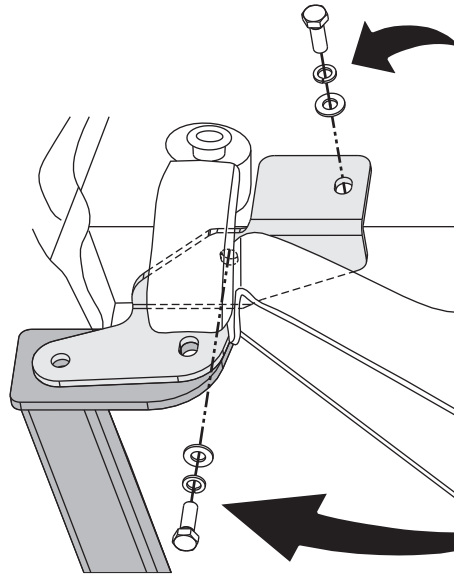
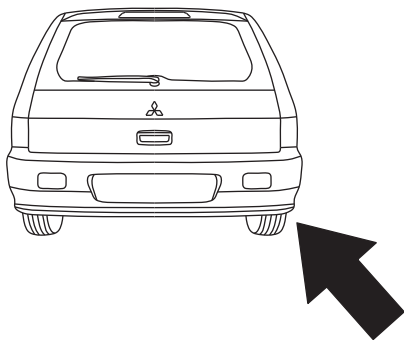

1		x 1		8	M12x50	x 1
				9	M12x40	x 4
				10	M10x1,25x30	x 8
				11	∅ 37x∅13x3 13 (DIN 9021)	x 4
2		x 1		12	∅ 13	x 3
				13	∅ 10.5	x 8
				14	∅ 12.2	x 5
				15	∅ 10.2	x 8
3		x 1		16	M12	x 3
4		x 1				
5		x 1				
6		x 1				
7		x 1				



06







- 1x  M10x1,25x30mm
- 1x  $\varnothing 10,2\text{mm}$
- 1x  $\varnothing 10,5\text{mm}$

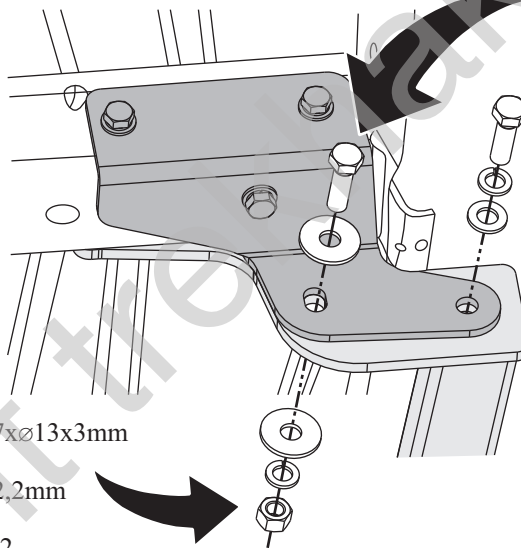
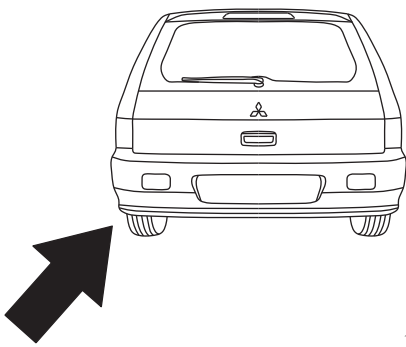

- 1x  M10x1,25x30mm
- 1x  $\varnothing 10,2\text{mm}$
- 1x  $\varnothing 10,5\text{mm}$

07





- 1x  M12x40mm
- 1x  $\varnothing 37 \times 13 \times 3\text{mm}$



- 1x  M12x40mm
- 1x  $\varnothing 12,2\text{mm}$
- 1x  $\varnothing 13\text{mm}$

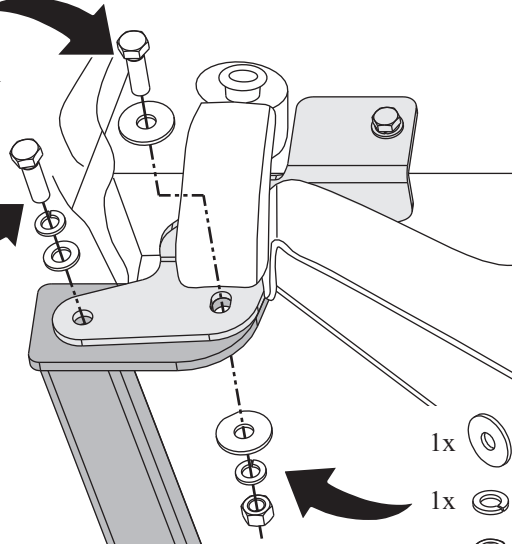
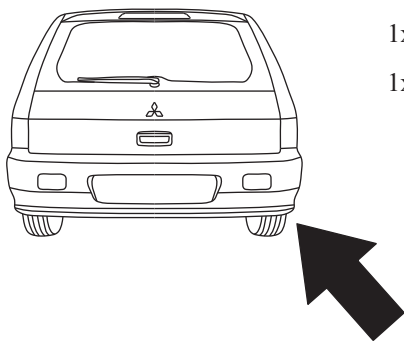

- 1x  $\varnothing 37 \times 13 \times 3\text{mm}$
- 1x  $\varnothing 12,2\text{mm}$
- 1x  M12

08



- 1x  M12x40mm
- 1x  $\varnothing 37 \times 13 \times 3\text{mm}$

- 1x  M12x40mm
- 1x  $\varnothing 12,2\text{mm}$
- 1x  $\varnothing 13\text{mm}$

- 1x  $\varnothing 37 \times 13 \times 3\text{mm}$
- 1x  $\varnothing 12,2\text{mm}$
- 1x  M12

09

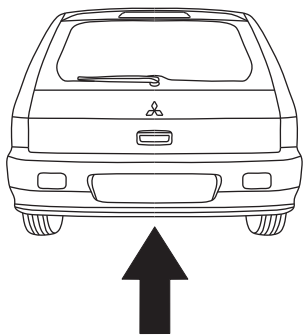

1x M12x50mm

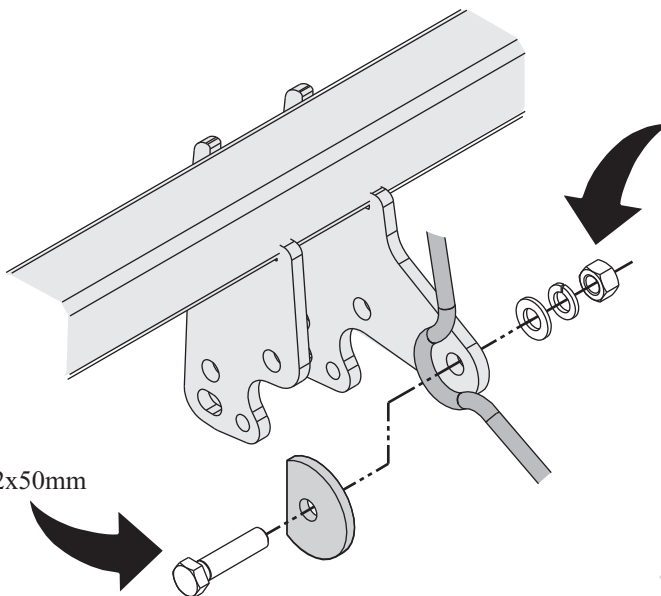

1x  $\varnothing 13\text{mm}$

1x  $\varnothing 12,2\text{mm}$

1x  M12

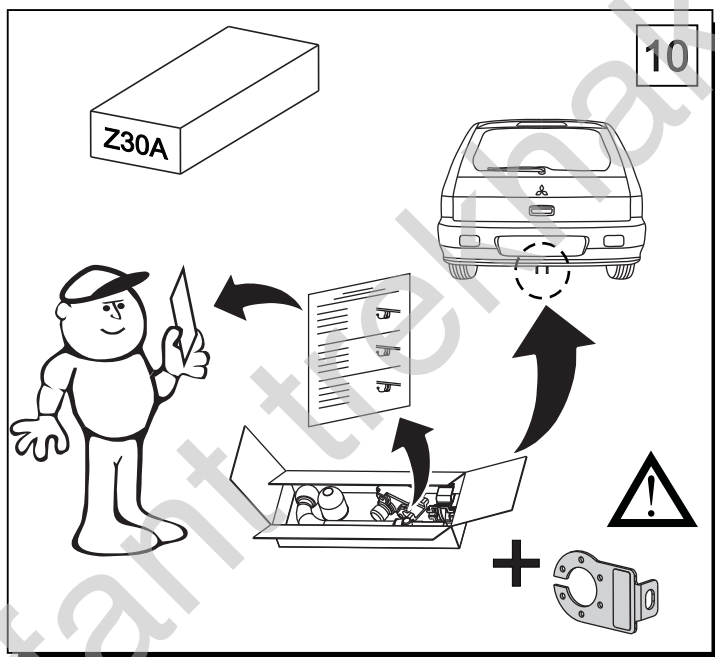

10

M6 - 11 Nm
M10 - 50 Nm
M14 - 138 Nm

M8 - 25 Nm
M12 - 87 Nm
M16 - 210 Nm



 0 km \rightarrow  1000 km