

FITTING INSTRUCTION

Clamp mark in acc. with		Cables joining
ISO	PN	
1	L	Left directional lights
2	+	Rear fog lights
3	31	Ground
4	R	Right directional lights
5	58R	Right side parking lights
6	54	Stoplights
7	58L	Left side parking lights

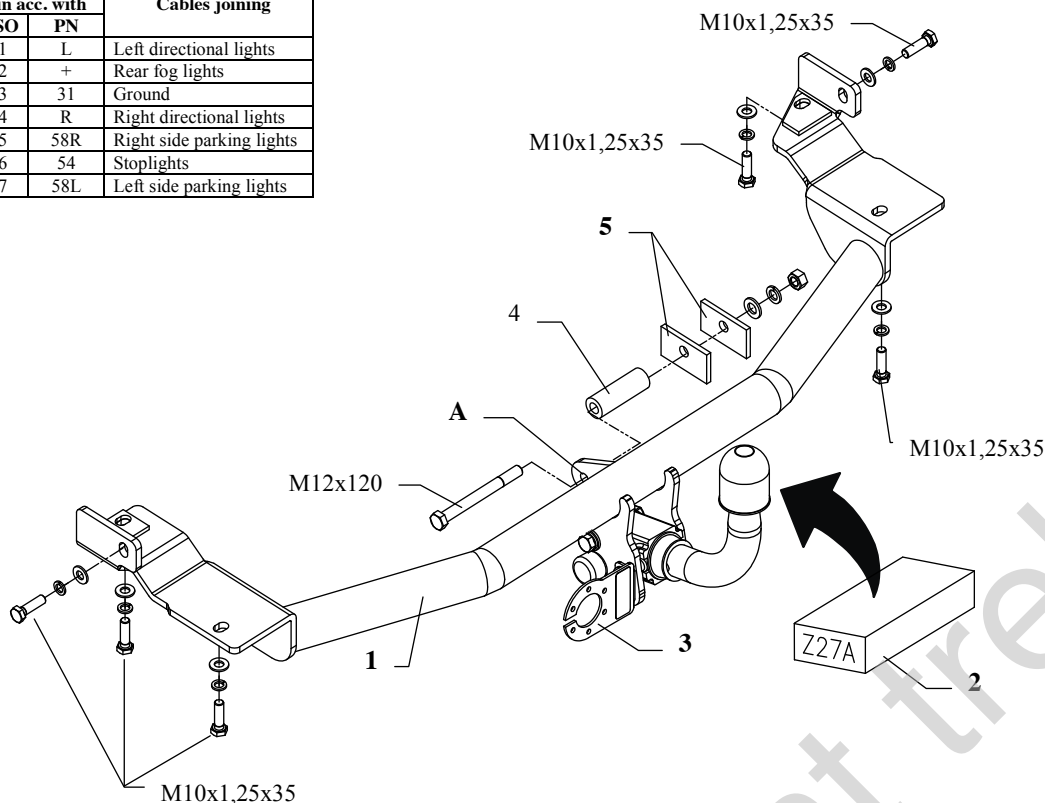

This towbar is designed to assembly in following car: **MITSUBISHI SPACEWAGON, VAN (N5, N8, N9)**, produced since 11.1998 till 04.2004, catalogue no. **Z27A** and is prepared to tow trailers max total weight **1600 kg** and max vertical load **80 kg**.

From manufacturer

Thank you for buying our product. Their reliability has been confirmed in many tests. Reliability of towbar depends also on correct assembly and right operation. For this reasons we kindly ask to read carefully this instruction and apply to hints.

The towbar should be install in points described by a car producer.

The instruction of the assembly

1. Disassemble the rear bumper.
2. Take out the spare wheel.
3. Position the main bar of the towbar (pos. 1) to chassis members and fix it through the original holes using bolts M10x1,25x35mm (pos. 7).
4. Through the hole (pos. A) and original towing eye fix using bolt M12x120mm (pos. 6) together with washers (pos. 5) and distance sleeve $\varnothing 25 \times \varnothing 13 \text{mm}$, L=59mm (pos. 4).
5. Cut the bumper according to the fig.2, then reassemble it.

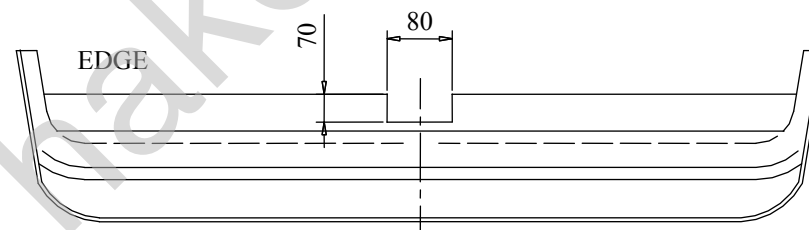

Fig. 2

6. Fix body of the automat and place tow-ball according to supplied instruction. Note! Remember to place socket plate (pos. 3) as shown on the drawing 1.
7. Tighten all nuts and bolts according to the torque shown in the table.
8. Connect to the electric wires according to the instructions of the car.
9. Complete the paint cover of towbar (during the mounting paint cover could be destroyed).

Torque settings for nuts and bolts (8,8):	
M 8 - 25 Nm	M 10 - 55 Nm
M 12 - 85 Nm	M 14 - 135 Nm









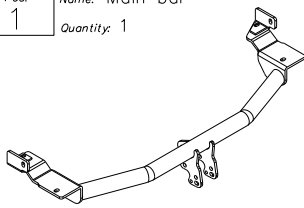

NOTE

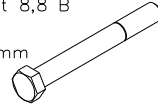
After install the towbar you should get adequate note in registration book (at authorised service station).The car should be equipped with:

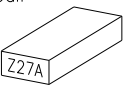
- Indicators
- Tow mirrors

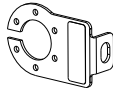
After 1000km of exploitation check all bolts and nuts. The ball of towbar must be always kept clear and conserve with a grease.

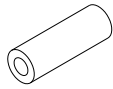
Towbar accessories:

Pos. 1 Name: Main bar Quantity: 1 	Pos. 5 Name: Washer Quantity: 2 Dim.: 70x40x6mm 	Pos. 10 Name: Plain washer Quantity: 6 Dim.: Ø 10,5 mm 
	Pos. 6 Name: Bolt 8,8 B Quantity: 1 Dim.: M12x120mm 	Pos. 11 Name: Spring washer Quantity: 1 Dim.: Ø 12,2 mm 
Pos. 2 Name: Tow ball Quantity: 1 	Pos. 7 Name: Bolt 8,8 B Quantity: 6 Dim.: M10x1.25x35mm 	Pos. 12 Name: Spring washer Quantity: 6 Dim.: Ø 10,2 mm 
Pos. 3 Name: Socket plate Quantity: 1 	Pos. 8 Name: Nut 8 B Quantity: 1 Dim.: M12 	
Pos. 4 Name: Distance sleeve Quantity: 1 Dim.: Ø25xØ13xmm L=59mm 	Pos. 9 Name: Plain washer Quantity: 1 Dim.: Ø 13 mm 	



PPUH AUTO-HAK S.J.

Produkcja Zaczepów Kulowych
Henryk i Zbigniew Nejman
76-200 SŁUPSK ul. Słoneczna 16K
tel/fax (059) 8-414-414; 8-414-413
E-mail: office@autohak.com.pl
www.autohak.com.pl

Towing hitch (without electrical set)

Class: **A50-X** Cat. no. **Z27A**

Designed for:

Manufacturer: **MITSUBISHI**

Model: **SPACEWAGON**

Type: **VAN (N5, N8, N9)**

produced since 11.1998 till 04.2004

Technical data:

D-value: 10,0 kN

maximum trailer weight: **1600 kg**

maximum vertical cup load: **80 kg**

Approval number according to Directive 94/20/EC: **e20*94/20*0621*00**

Foreword

This towbar is designed according to rules of safety traffic regulations. The towing hitch is a safety component and can be install only by qualified personnel. Any alteration or conversion of the towing hitch is prohibited and would lead to cancellation of design certification. Remove insulating compound and underseal from vehicle (if present) in the area of the matting surfaces of the towing hitch. The vehicle manufacturer's specifications regarding trailer load and max. vertical cup load are decisive for driving whereat values for the towing hitch cannot be exceeded.

D-value formula:

$$\frac{\text{Max trailer weight [kg]} \times \text{Max vehicle weight [kg]}}{\text{Max trailer weight [kg]} + \text{Max vehicle weight [kg]}} \times \frac{9,81}{1000} = D \text{ [kN]}$$