

FITTING INSTRUCTION

Clamp mark in acc. with		Cables joining
ISO	PN	
1	L	Left directional lights
2	+	Rear fog lights
3	31	Ground
4	R	Right directional lights
5	58R	Right side parking lights
6	54	Stoplights
7	58L	Left side parking lights

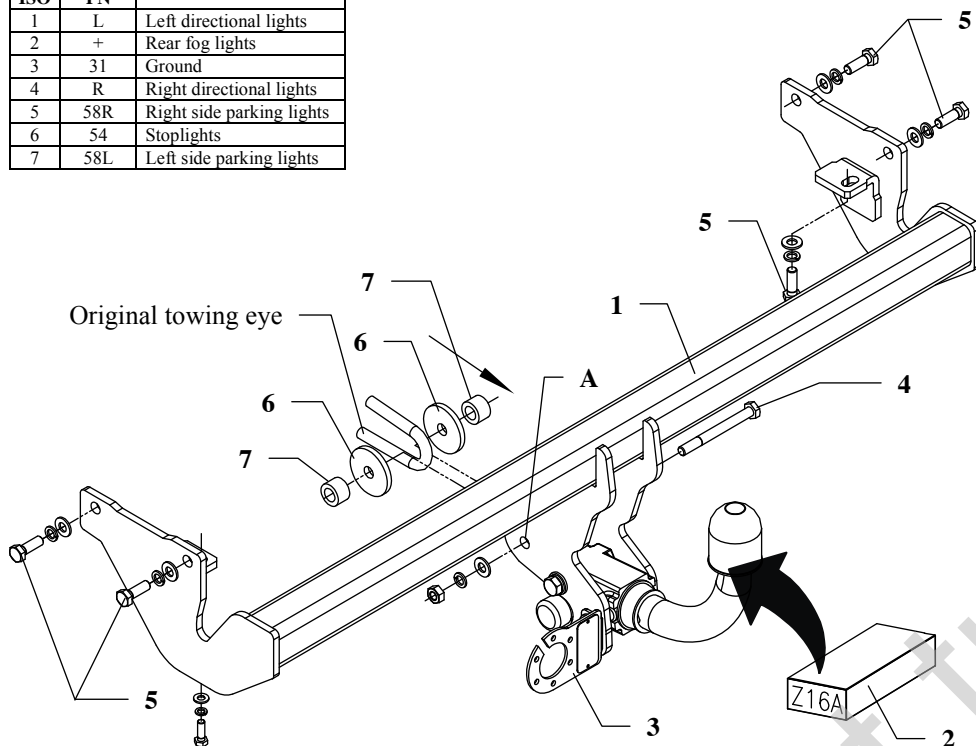

This towbar is designed to assembly in following cars:
MITSUBISHI SPACESTAR VAN (D40), produced since 03.1999 till 12.2006, catalogue no. **Z16A** and is prepared to tow trailers max total weight **1400 kg** and max vertical load **75 kg**.

From manufacturer

Thank you for buying our product. Their reliability has been confirmed in many tests. Reliability of towbar depends also on correct assembly and right operation. For this reasons we kindly ask to read carefully this instruction and apply to hints.

The towbar should be installing in points described by a car producer.

The instruction of the assembly

1. Disassemble the rear bumper.
2. Put main bar of the towbar (pos. 1) to the chassis member and fix it through the original holes using bolts M10x1,25x30mm (pos. 5).
3. Fix through the hole (pos. A) and original towing eye using bolt M12x100mm (pos. 4) together with big washers (pos. 6) and distance sleeves (pos. 7).
4. Reassemble the bumper.
5. Fix body of the automat and place tow-ball according to supplied instruction. Note! Remember to place socket plate (pos. 3) as shown on the drawing 1.
6. Tighten all nuts and bolts according to the torque shown in the table.
7. Connect to the electric wires according to the instruction of the car.
8. Complete the paint cover of towbar (during the mounting paint cover could be destroyed).

Torque settings for nuts and bolts (8,8):	
M 8 - 25 Nm	M 10 - 55 Nm
M 12 - 85 Nm	M 14 - 135 Nm



NOTE

After install the towbar you should get adequate note in registration book (at authorised service station).The car should be equipped with:

- Indicators
- Tow mirrors

Check all bolts and nuts after 1000km of exploitation. The ball of towbar must be always kept clear and conserve with a grease.

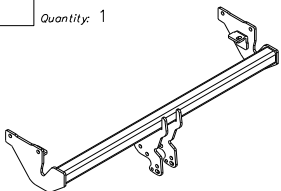
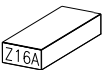
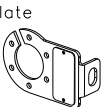
Towbar equipment:

Pos. 1	Name: Main bar Quantity: 1	Pos. 4	Name: Bolt 8,8 B Quantity: 1 Dim.: M12x100mm	Pos. 8	Name: Nut 8 B Quantity: 1 Dim.: M12
		Pos. 5	Name: Bolt 8,8 B Quantity: 6 Dim.: M10x1,25x35mm	Pos. 9	Name: Plain washer Quantity: 1 Dim.: Ø 13 mm
Pos. 2	Name: Tow ball Quantity: 1	Pos. 6	Name: Washer Quantity: 2 Dim.: Ø58xØ13x6mm	Pos. 10	Name: Plain washer Quantity: 6 Dim.: Ø 10,5 mm
		Pos. 7	Name: Distance sleeve Quantity: 2 Dim.: Ø25xØ13mm L = 16,5mm	Pos. 11	Name: Spring washer Quantity: 1 Dim.: Ø 12,2 mm
Pos. 3	Name: Socket plate Quantity: 1			Pos. 12	Name: Spring washer Quantity: 6 Dim.: Ø 10,2 mm
					



PPUH AUTO-HAK Sp.J.

Produkcja Zaczepów Kulowych
Henryk & Zbigniew Nejman
76-200 SŁUPSK ul. Słoneczna 16K
tel/fax (059) 8-414-414; 8-414-413
E-mail: office@autohak.com.pl
www.autohak.com.pl

Towing hitch (without electrical set)

Class: **A50-X** Cat. no. **Z16A**

Designed for:

Manufacturer: **MITSUBISHI**

Model: **SPACESTAR VAN (D40)**

produced since 03.1999 till 12.2006

Technical data:

D-value: 7,59 kN

maximum trailer weight: **1400 kg**

maximum vertical cup load: **75 kg**

Approval number according to Directive 94/20/EC: e20*94/20*1040*00

Foreword

This towbar is designed according to rules of safety traffic regulations. The towing hitch is a safety component and can be install only by qualified personnel. Any alteration or conversion of the towing hitch is prohibited and would lead to cancellation of design certification. Remove insulating compound and underseal from vehicle (if present) in the area of the matting surfaces of the towing hitch. The vehicle manufacturer's specifications regarding trailer load and max. vertical cup load are decisive for driving whereat values for the towing hitch cannot be exceeded.

D-value formula:

$$\frac{\text{Max trailer weight [kg]} \times \text{Max vehicle weight [kg]}}{\text{Max trailer weight [kg]} + \text{Max vehicle weight [kg]}} \times \frac{9,81}{1000} = D \text{ [kN]}$$