

## FITTING INSTRUCTION

Clamp mark in acc. with		Cables joining
ISO	PN	
1	L	Left directional lights
2	+	Rear fog lights
3	31	Ground
4	R	Right directional lights
5	58R	Right side parking lights
6	54	Stoplights
7	58L	Left side parking lights

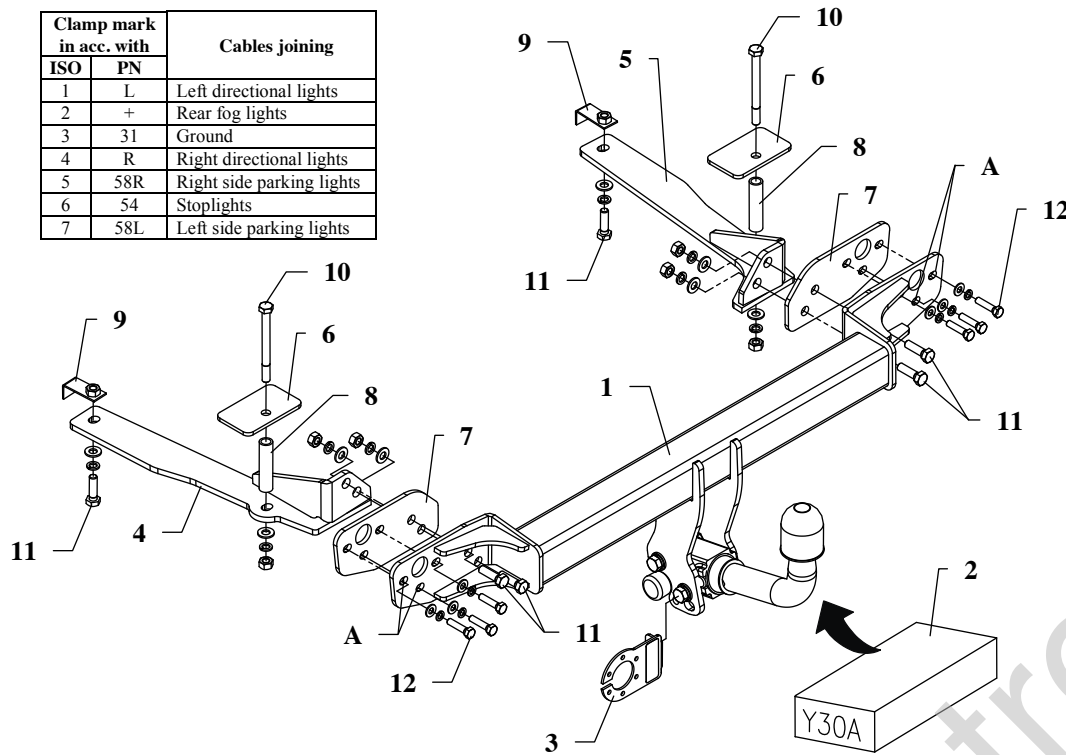

Fig.1

This towbar is designed to assembly in following car:  
**HONDA ACCORD 4 door, (CL7, CL9 CN1), besides motor 2,4l and Type S** produced since 01.2003 till 07.2008, catalogue no. **Y30A** and is prepared to tow trailers max total weight **1500 kg** and max vertical load **75 kg**.

### From manufacturer

Thank you for buying our product. Their reliability has been confirmed in many tests. Reliability of towing hitch depends also on correct assembly and right operation. For this reasons we kindly ask to read carefully this instruction and apply to hints.

*The towing hitch should be install in points described by a car producer.*

## The instruction of the assembly

1. Disassemble bumper and metal reinforcement (not used any more), disassemble side and rear cover plates in trunk.
2. In factory marked points (on the right and left side of the trunk) make holes  $\varnothing 18$  mm.
3. In maked holes put sleeves  $\varnothing 17$  mm (pos. 8), length = 73 mm.
4. To rear side put main bar of towing hitch (pos. 1) in that way, so holes pos. A agree to holes for unscrewed reinforcement and fix using bolts M8x35mm (loosely) – pos. 12.
5. Elements (pos. 4 and 5) put to chassis members and rear side and fix using bolts M10x110 mm (pos. 10) and M10x35mm (pos. 11).
6. Assemble masking cover and bumper after cut his fragment 80x50mm – see fig. 2.

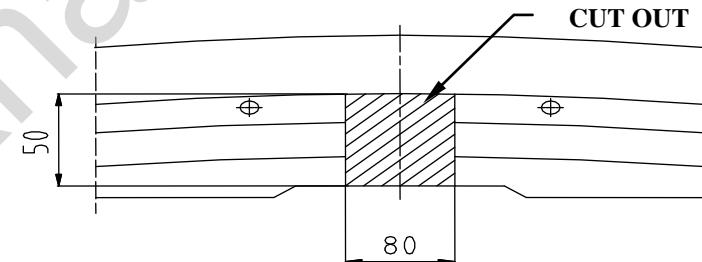

Fig.2.

7. Tighten all bolts according to the torque shown in the table.
8. Fix body of the automat and place tow-ball according to supplied instruction. Note! Remember to place socket plate (pos. 3) as shown on the drawing 1.
9. Connect electric wires of 7-poles socket according to the instruction of the car. (Recommend to make at authorized service station)
10. Complete the paint coating damaged during installation.

Torque settings for nuts and bolts (8,8):

**M 8** - 25 Nm                      **M 10** - 55 Nm

**M 12** - 85 Nm                      **M 14** - 135 Nm











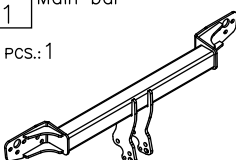

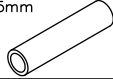

### NOTE

After installation of a towing hitch you should get adequate note in registration book (at authorised service station). The car should be equipped with:

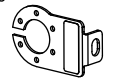
- Indicators
- Tow mirrors

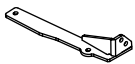
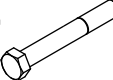
After 1000km of exploitation check all bolts and nuts. The ball of towing hitch must be always kept clear and conserve with a grease.

Towbar accessories:

Pos. 1 Main bar PCS.: 1 	Pos. 6 Fish-plate PCS.: 2 	Pos. 12 Bolt 8.8 B M8x35mm PCS.: 6 
	Pos. 7 Plate PCS.: 2 	Pos. 13 Washer ø10,5mm PCS.: 8 
Pos. 2 Tow ball (mounting set) PCS.: 1 	Pos. 8 Distance sleeve ø17,2x2.35mm L=73mm PCS.: 2 	Pos. 14 Washer ø8,5mm PCS.: 6 
Pos. 3 Socket plate PCS.: 1 	Pos. 9 Jib with the nut PCS.: 2 	Pos. 15 Spring washer ø10,2mm PCS.: 8 
Pos. 4 Left bracket PCS.: 1 	Pos. 10 Bolt 8.8 B M10x110mm PCS.: 2 	Pos. 16 Spring washer ø8,2mm PCS.: 6 
Pos. 5 Right bracket PCS.: 1 	Pos. 11 Bolt 8.8 B M10x35mm PCS.: 6 	Pos. 17 Nut 8.8 B M10 PCS.: 6 



**PPUH AUTO-HAK S.J.**

Produkcja Zaczepów Kulowych  
Henryk i Zbigniew Nejman  
76-200 SŁUPSK ul. Słoneczna 16K  
tel/fax (059) 8-414-414; 8-414-413  
E-mail: office@autohak.com.pl  
www. autohak.com.pl

## Towing hitch (without electrical set)

Class: **A50-X** Cat. no. **Y30A**

Designed for:

Manufacturer: **HONDA**

Model: **ACCORD**

Type: **4 door, (CL7, CL9, CN1)**

**besides motor 2,4l and Type S**

produced since 01.2003 till 07.2008

Technical data:

**D-value: 8,26 kN**

maximum trailer weight: **1500 kg**

maximum vertical cup load: **75 kg**

Approval number according to Directive 94/20/EC: **e20\*94/20\*0979\*00**

### Foreword

This towing hitch is designed according to rules of safety traffic regulations. The towing hitch is a safety component and can be install only by qualified personnel. Any alteration or conversion of the towing hitch is prohibited and would lead to cancellation of design certification. Remove insulating compound and underseal from vehicle (if present) in the area of the matting surfaces of the towing hitch.

The vehicle manufacturer's specifications regarding trailer mass and max. vertical cup mass are decisive for driving whereat values for the towing hitch cannot be exceeded.

*D-value formula:*

$$\frac{\text{Max trailer weight [kg]} \times \text{Max vehicle weight [kg]}}{\text{Max trailer weight [kg]} + \text{Max vehicle weight [kg]}} \times \frac{9,81}{1000} = D \text{ [kN]}$$