

PPUH AUTO-HAK Sp.J.

Henryk i Zbigniew Nejman
ul. Słoneczna 16K 76-200 SŁUPSK
POLAND

tel/fax +48 59 8 414 414; +48 59 8 414 413

e-mail: office@autohak.com.pl

www.autohak.com.pl



AUTO-HAK

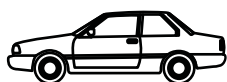

CHEVROLET CAPTIVA

(C100), (dotyczy wiązki: model ze złączem elektrycznym haka)

(C100), (dotyczy wiązki: model bez złącza elektrycznego haka)

Cat. no:

X20A



09.2006 →

e20

e20*94/20*0253*00



2h

D

11,0 kN



R=2000 kg



S=80 kg



19 kg

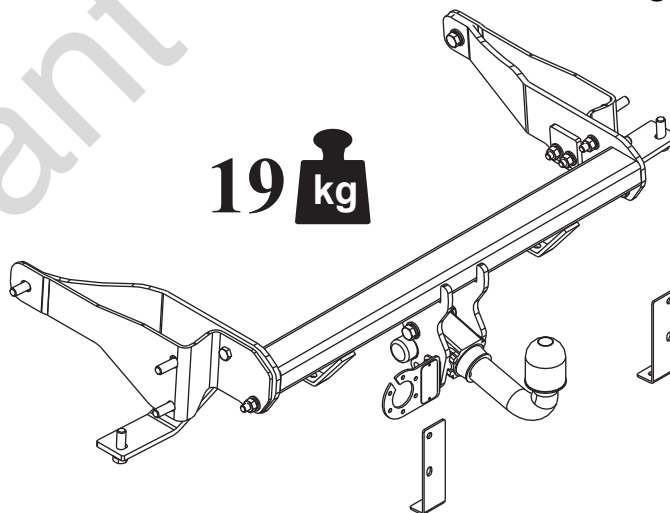

M6 - 8,5 Nm
M10 - 41 Nm
M14 - 112 Nm

M8 - 20 Nm
M12 - 70 Nm
M16 - 170 Nm









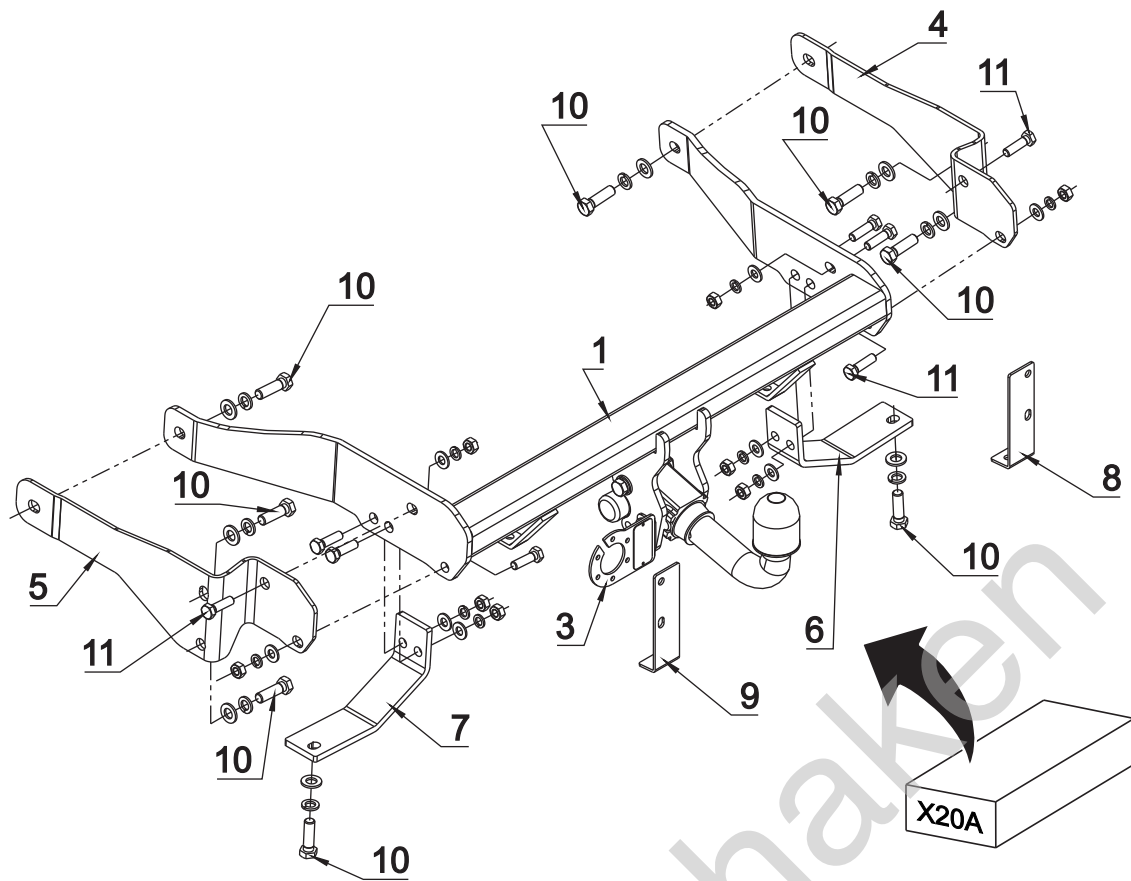

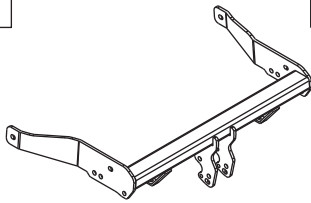

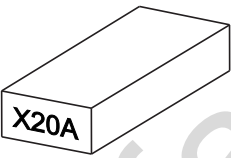
0 km →

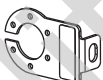

1000 km



1		x1		10	M12x40	x8
				11	M10x35	x8
2		x1		12	∅ 13	x8
				13	∅ 10.5	x8
				14	∅ 12.2	x8
				15	∅ 10.2	x8
				16	M10	x8
3		x1	Art. nr-BL1X20A			
4		x1				
5		x1				
6		x1				
7		x1				
8		x1				
9		x1				

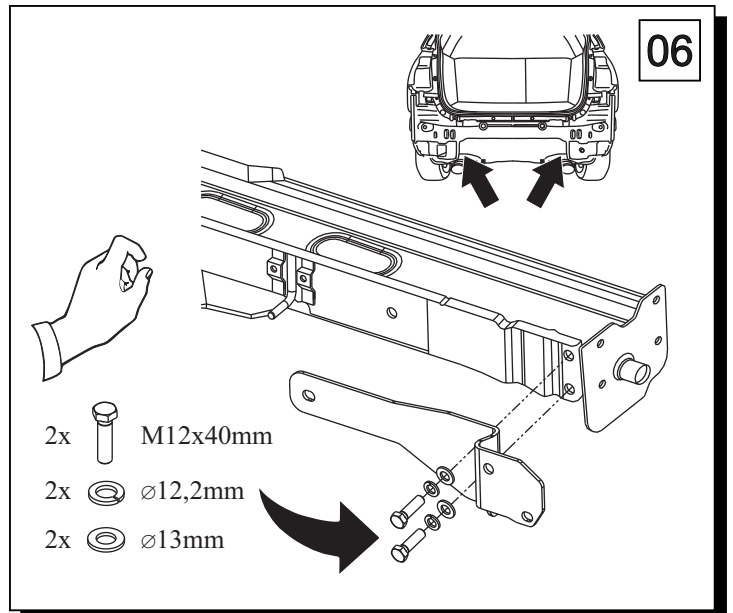
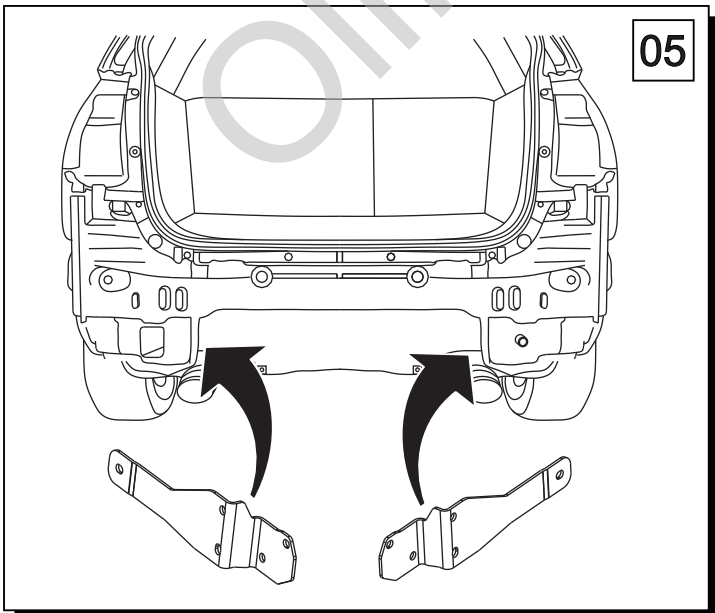
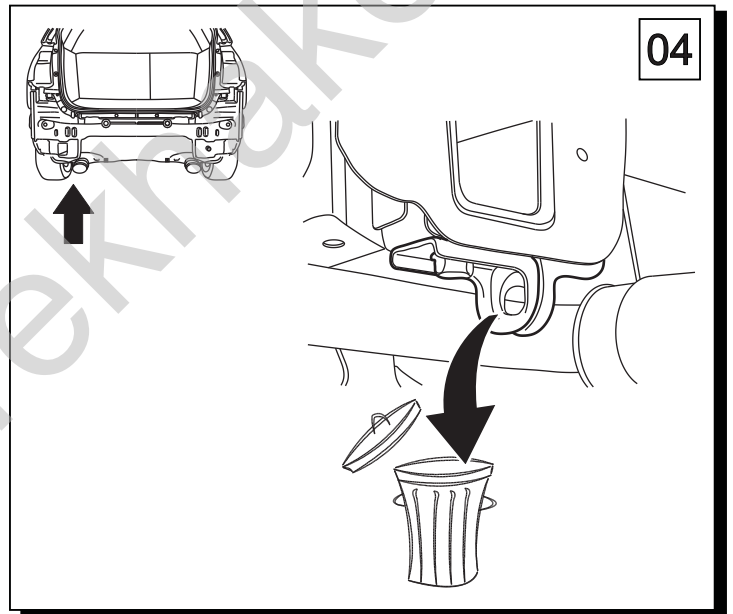
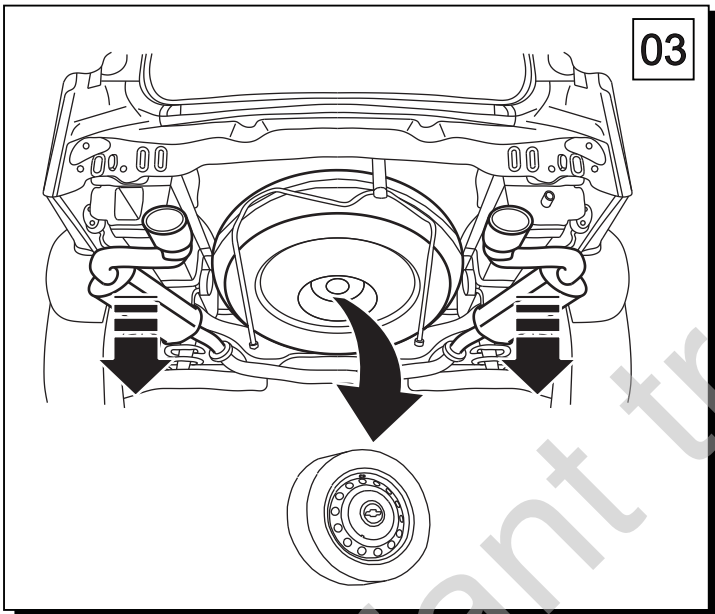
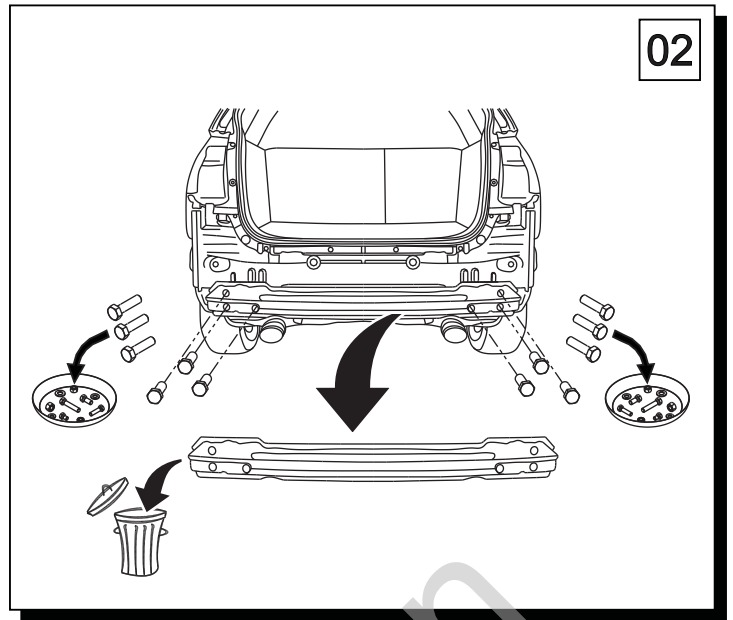
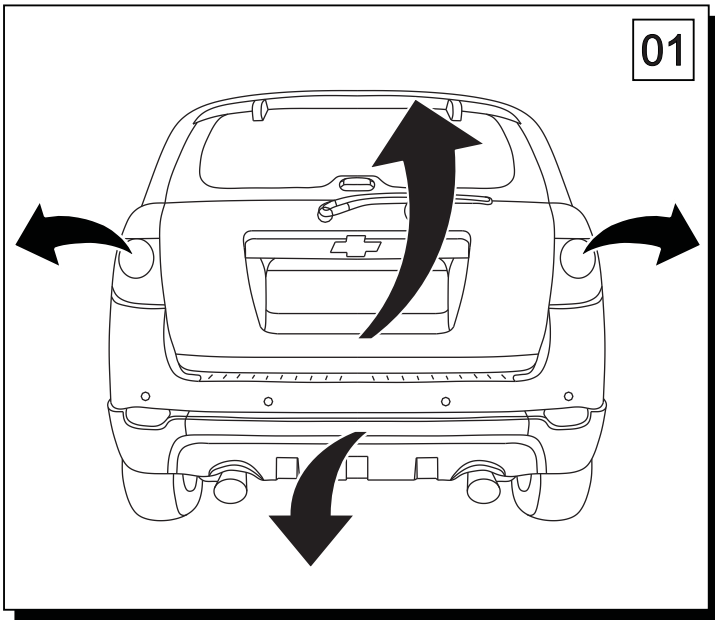

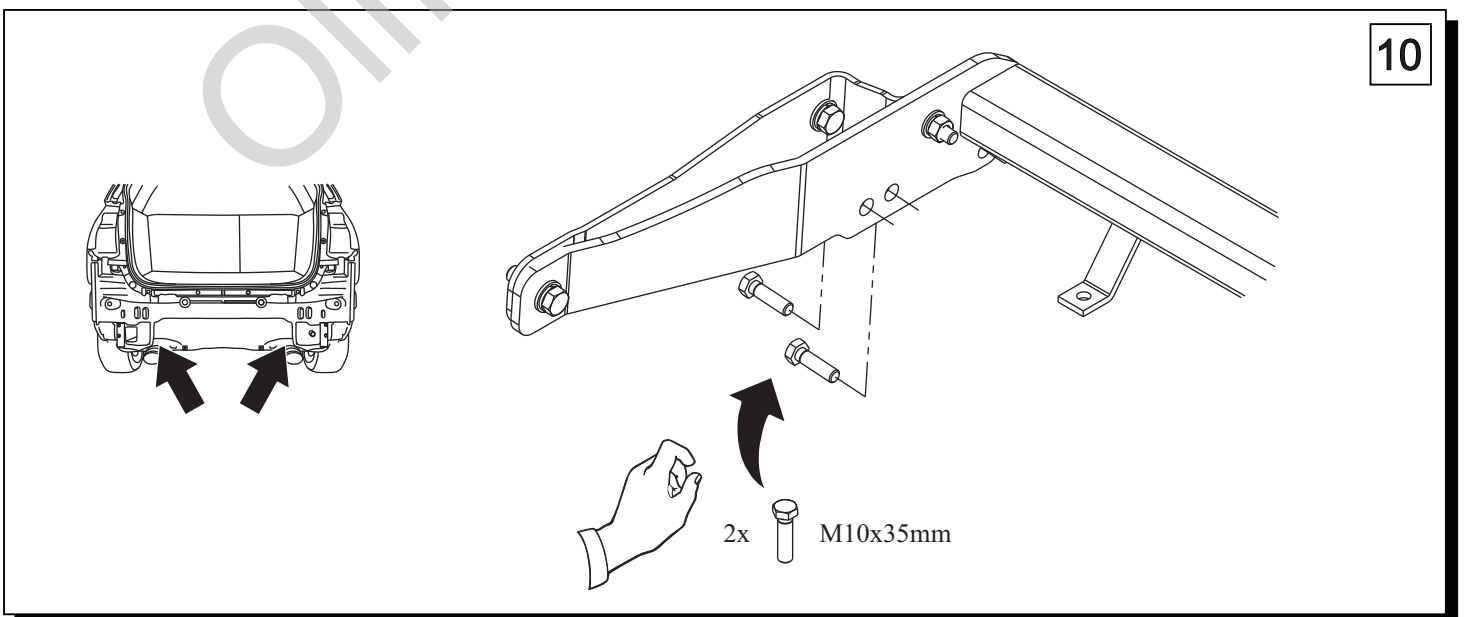
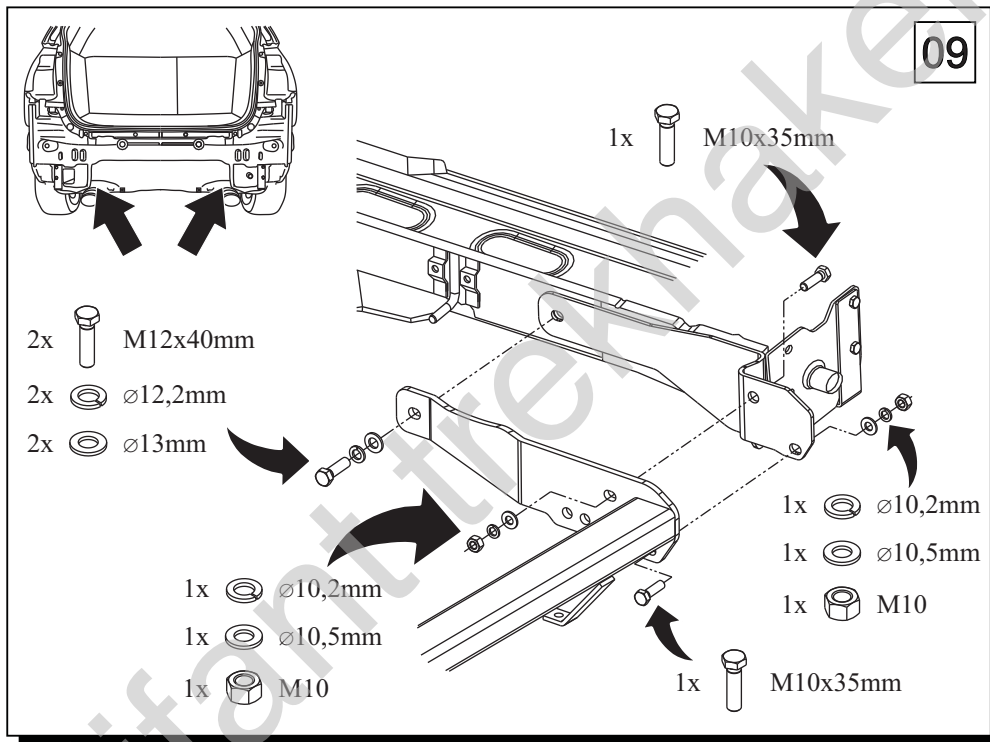
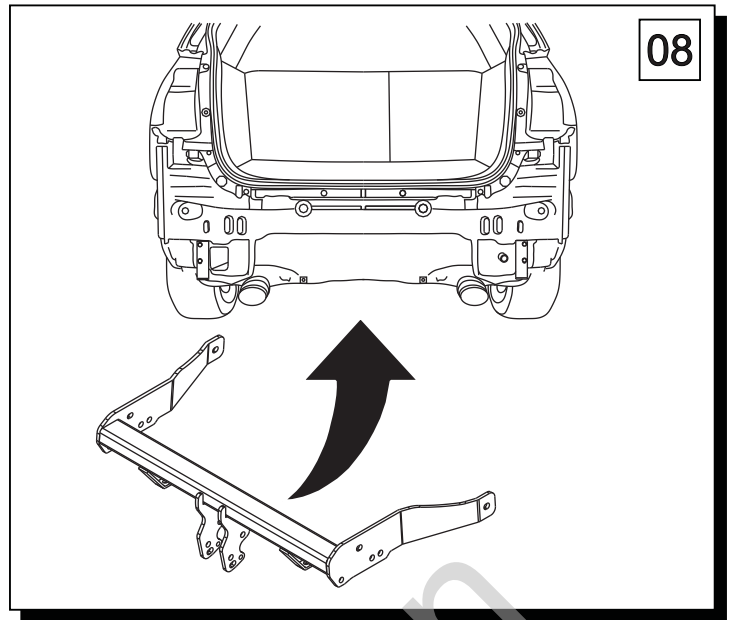
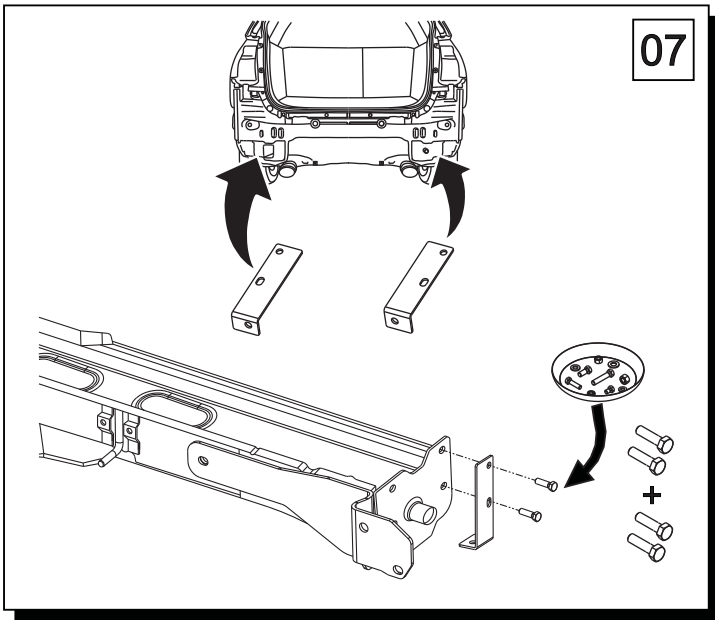

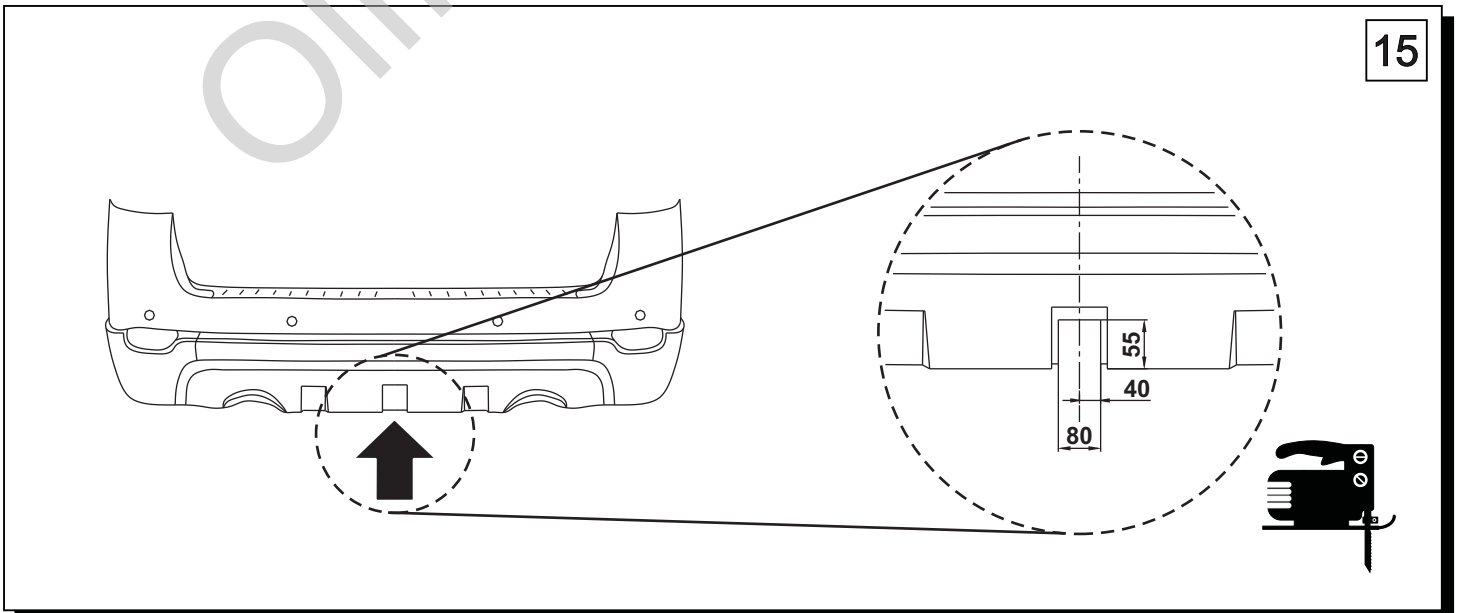
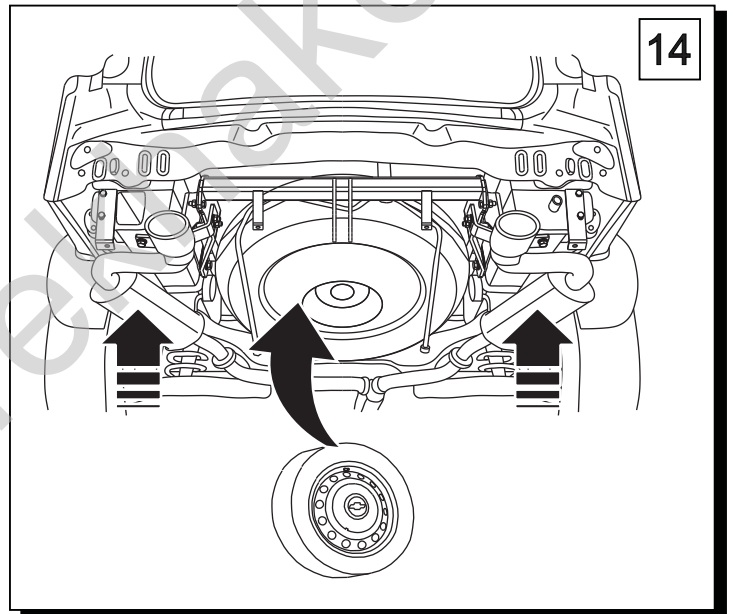
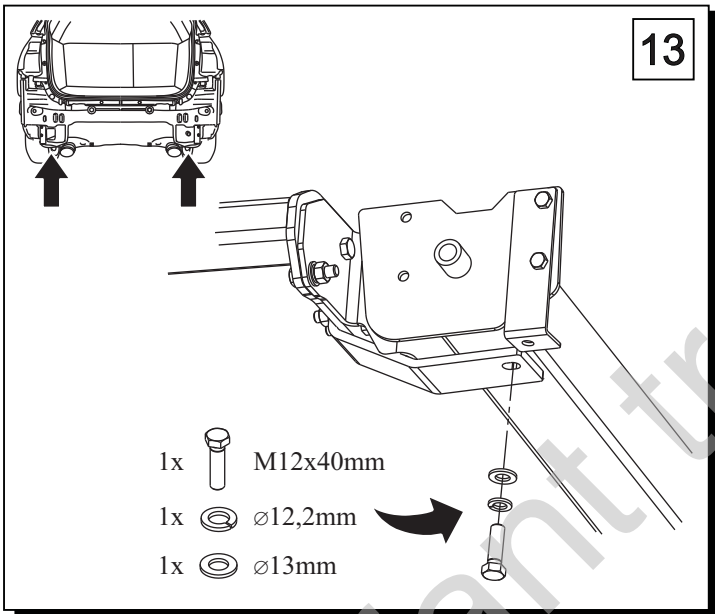
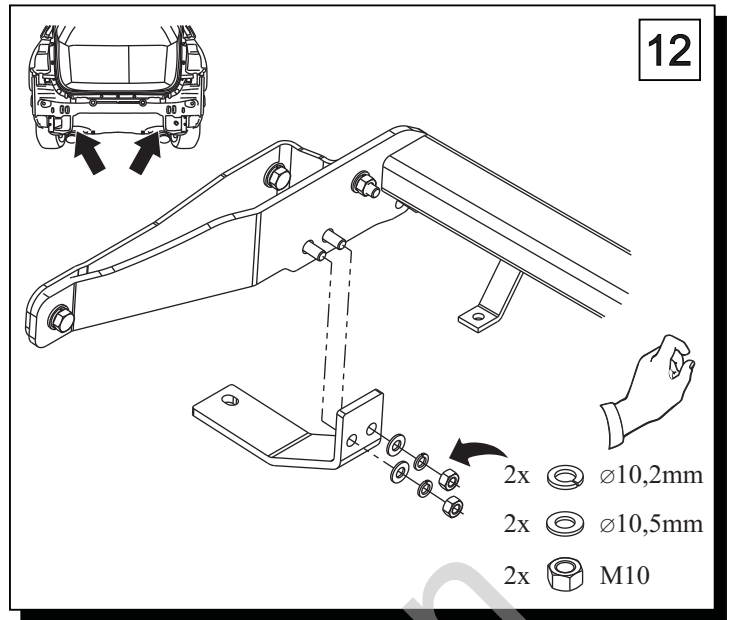
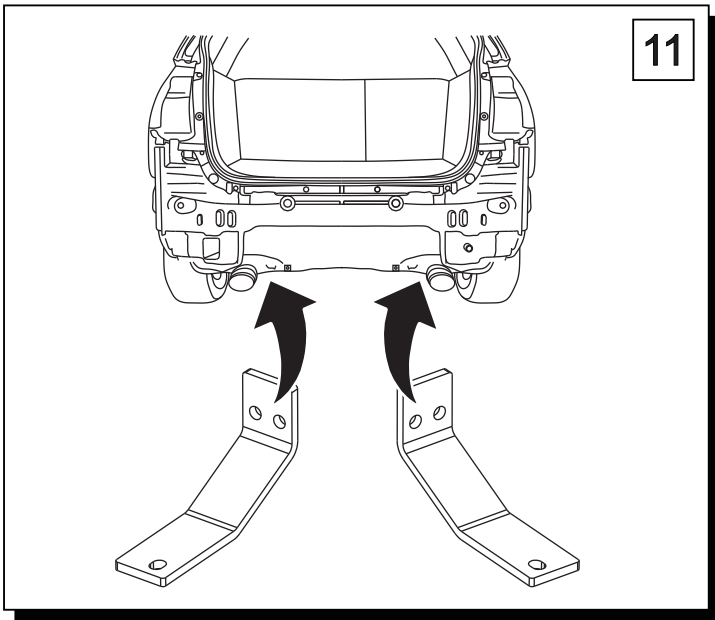

16

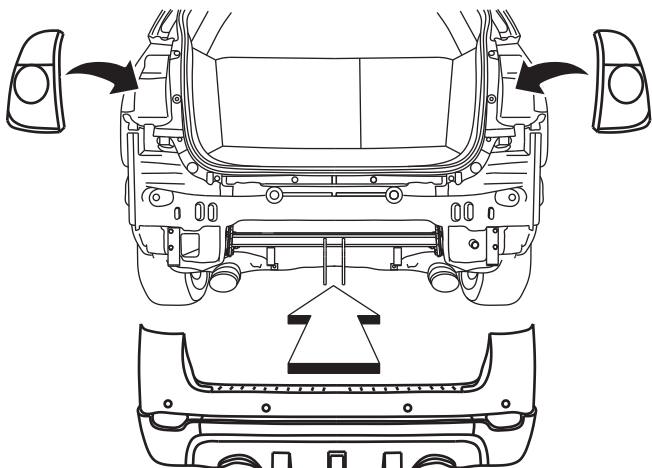

17

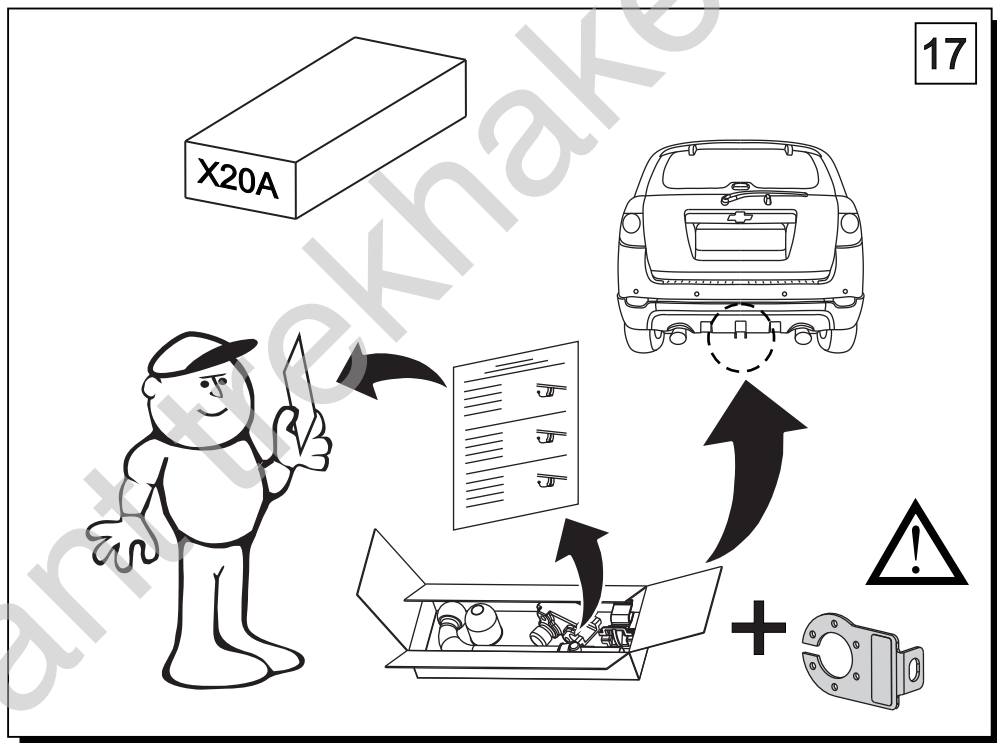

M6 - 11 Nm
M10 - 50 Nm
M14 - 138 Nm

M8 - 25 Nm
M12 - 87 Nm
M16 - 210 Nm

0 km → 1000 km