

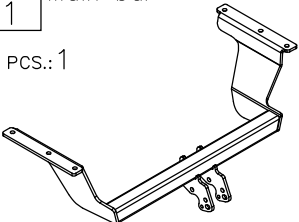

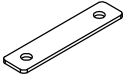





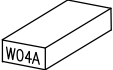

Towing hitch accessories:

Pos. 1 Main bar PCS.: 1 	Pos. 5 Washer I PCS.: 4 	Pos. 10 Nut 8 B M10 PCS.: 12 
	Pos. 6 Washer II PCS.: 4 	Pos. 11 Washer ø10,5mm PCS.: 16 
Pos. 2 Tow ball (mounting set) PCS.: 1 	Pos. 7 Distance sleeve ø21.3x2.35mm L=16mm PCS.: 4 	Pos. 12 Spring washer ø10,2mm PCS.: 16 
Pos. 3 Socket plate PCS.: 1 	Pos. 8 Bolt 8.8 B M10x35mm PCS.: 12 	
Pos. 4 Fish-plate PCS.: 2 	Pos. 9 Bolt 8.8 B M10x1.25x50mm PCS.: 4 	

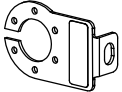

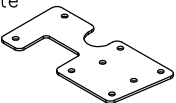
PPUH AUTO-HAK S.J.

Produkcja Haków Holowniczych
Henryk & Zbigniew Nejman
76-200 SŁUPSK ul. Słoneczna 16K
tel/fax (059) 8-414-414; 8-414-413
E-mail: office@autohak.com.pl
www.autohak.com.pl

Towing hitch (without electrical set)

Class: **A50-X** Cat. no. **W04A**

Designed for:

Manufacturer: **SUZUKI**

Model: **BALENO**

Type: **ESTATE (EG)**

produced since 08.1996 till 05.2002

Technical data:

D-value: 7,04 kN

maximum trailer weight: **1300 kg**

maximum vertical cup load: **75 kg**

Approval number according to Directive 94/20/EC: **e20*94/20*0364*00**

Foreword

This towing hitch is designed according to rules of safety traffic regulations. The towing hitch is a safety component and can be install only by qualified personnel. Any alteration or conversion of the towing hitch is prohibited and would lead to cancellation of design certification. Remove insulating compound and underseal from vehicle (if present) in the area of the matting surfaces of the towing hitch. The vehicle manufacturer's specifications regarding trailer load and max. vertical cup load are decisive for driving whereat values for the towing hitch cannot be exceeded.

D-value formula:

$$\frac{\text{Max trailer weight [kg]} \times \text{Max vehicle weight [kg]}}{\text{Max trailer weight [kg]} + \text{Max vehicle weight [kg]}} \times \frac{9,81}{1000} = D \text{ [kN]}$$

FITTING INSTRUCTION

Clamp mark in acc. with		Cables joining
ISO	PN	
1	L	Left directional lights
2	+	Rear fog lights
3	31	Ground
4	R	Right directional lights
5	58R	Right side parking lights
6	54	Stoplights
7	58L	Left side parking lights

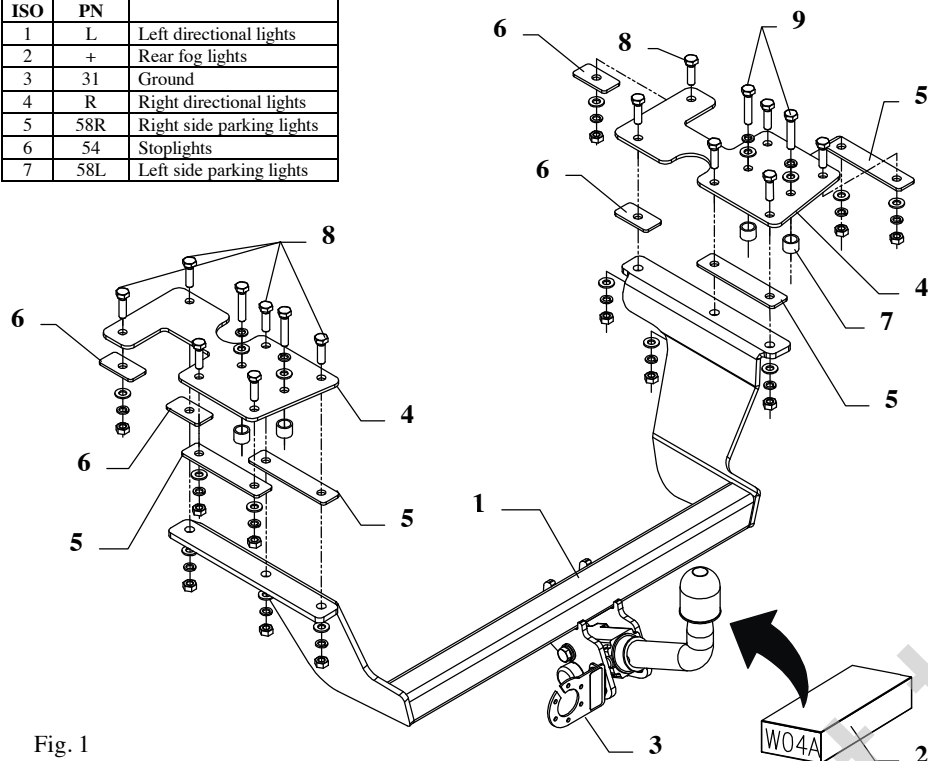

Fig. 1

This towing hitch is designed to assembly in following cars:
SUZUKI BALENO ESTATE (EG), produced since 08.1996 till 05.2002,
 catalogue no. **W04A** and is prepared to tow trailers max total weight
1300 kg and max vertical load **75 kg**.

From manufacturer

Thank you for buying our product. Their reliability has been confirmed in many tests. Reliability of towing hitch depends also on correct assembly and right operation. For this reasons we kindly ask to read carefully this instruction and apply to hints.

The towing hitch should be install in points described by a car producer.

The instruction of the assembly

- One ought to remove from the trunk:
 - the fitted carpet,
 - plastic cover plate from the back piece,
 - plastic cover plate of the floor,
 - the metal rise of the floor from the left and right side.

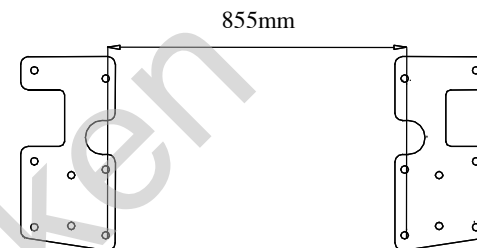

Fig. 2

- Unscrew bolts fastening arms of the bumper.
- Apply fish-plates (pos. 4) such way, so holes, in which enter bolts M10x1,25x50mm (pos. 9) overlapped on holes, which were previously unscrewing bolts fastening arms of the bumper. Then marked the contour of fish-plates and after this put aside fish-plates – inside contours remove the anti-noise layer. Put fish-plates (pos. 4) in this way, so holes for bolts M10x1,25x50mm (pos. 9) agree with holes after disassembly of towing hitch brackets. Mark contour of the fish—plates, next take them of and remove protective layer from inside of contour.
- On holes fastening arms of the bumper put distance sleeves L=16mm (pos. 7). Then apply again fish-plates (pos. 4) and fix with bolts M10x1,25x50mm (pos. 9) as showed on the fig. 1.
- Attention! Make sure whether fish-plates lay as one showed on the fig. 2.**
- By remaining holes of fish-plates (pos. 4) drill through holes $\phi 10,5$ mm. Then into all holes insert bolts M10x35mm (pos. 8).
- From the bottom of the car on protruding bolts put distance washers (pos. 5 and 6) and the main bar of the towing hitch (pos. 1) and fix as showed on the fig. 1.
- Fix body of the automat and place tow-ball according to supplied instruction. Note! Remember to place socket plate (pos. 3) as shown on the drawing 1.
- Tighten all bolts according to the torque shown in the table.
- Connect electric wires of 7-poles socket according to the instruction of the car. (Recommend to make at authorized service station).
- Complete paint layer damaged during installation.

Torque settings for nuts and bolts (8,8):	
M 8 - 25 Nm	M 10 - 55 Nm
M 12 - 85 Nm	M 14 - 135 Nm

NOTE

After install the towing hitch you should get adequate note in registration book (at authorised service station).The car should be equipped with:

- Indicators
- Tow mirrors

After 1000km check all bolts and nuts. The ball of towing hitch must be always kept clear and conserve with a grease.