

FITTING INSTRUCTION

Clamp mark in acc. with		Cables joining
ISO	PN	
1	L	Left directional lights
2	+	Rear fog lights
3	31	Ground
4	R	Right directional lights
5	58R	Right side parking lights
6	54	Stoplights
7	58L	Left side parking lights

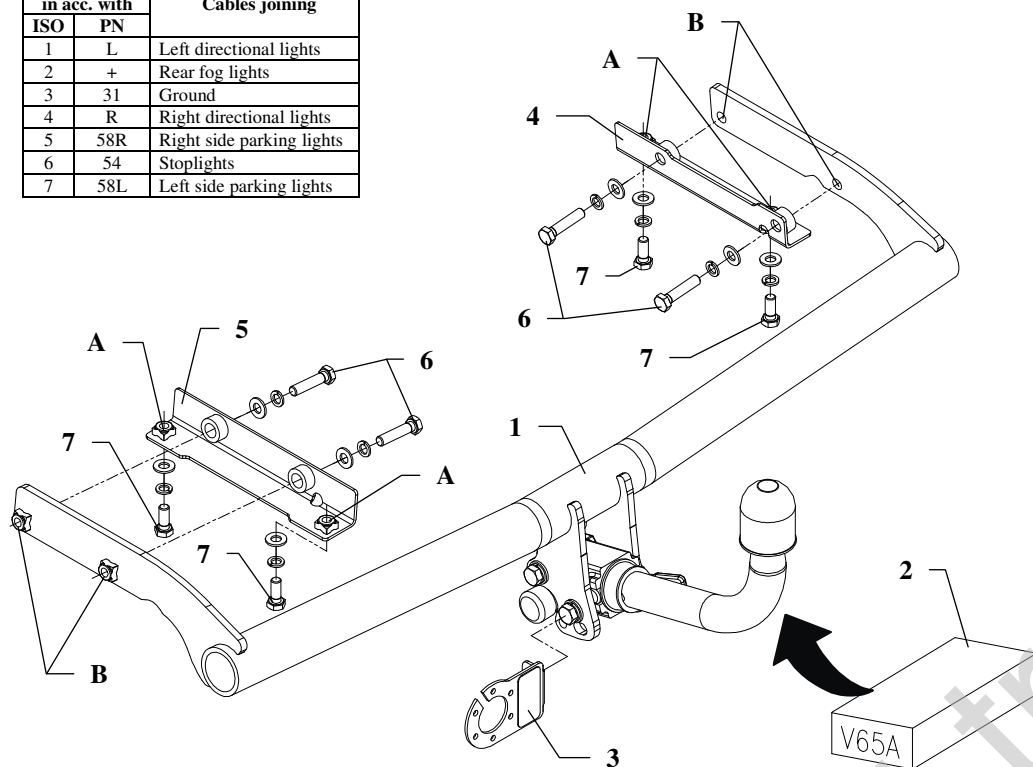

This towbar is designed to assembly in following cars: **NISSAN NOTE, 5 DOORS (E11), VAN**, produced since 03.2006 till 09.2013, catalogue no. **V65A** and is prepared to tow trailers max total weight **1200 kg** and max vertical load **50 kg**.

From manufacturer

Thank you for buying our product. Their reliability has been confirmed in many tests. Reliability of towbar depends also on correct assembly and right operation. For this reasons we kindly ask to read carefully this instruction and apply to hints.

The towbar should be install in points described by a car producer.

The instruction of the assembly

1. Disassemble a rear bumper.
2. Disassemble supports of bumper on the left and right side (not used any more).
3. The angled elements (elements No 4 and 5) slip into the steel frame of the car so the holes could be in the same place that the holes in the car are. Then please screw them, not tight, using screws M10x25 mm (elements 7) throught the points A.
4. Put main bar of the towbar (pos. 1) to chassis frame. Fix using bolts M10x45mm (pos. 6) through holes (pos. B) as shown on the figure 1.
5. Cut out fragment bumper's reinforcement according to figure 2.

Fig. 2

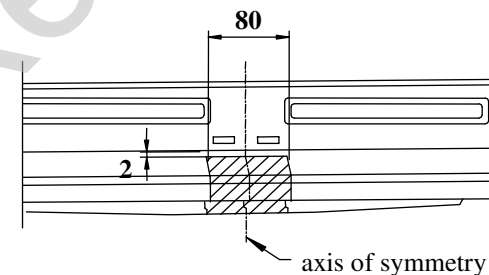

6. Reassemble a bumper after cut out its fragment (underneath, in axis of symmetry) – width 80mm and depth 70mm.
7. Fix body of the automat and place tow-ball according to supplied instruction. Note! Remember to place socket plate (pos. 3) as shown on the drawing 1.
8. Tighten all bolts according to the torque shown in the table.
9. Connect electric wires of 7-poles socket according to the instruction of the car. (Recommend to make at authorized service station).
10. Complete paint layer damaged during installation.

Torque settings for nuts and bolts (8,8):	
M 8 - 25 Nm	M 10 - 55 Nm
M 12 - 85 Nm	M 14 - 135 Nm







NOTE

After install the towbar you should get adequate note in registration book (at authorised service station).The car should be equipped with:

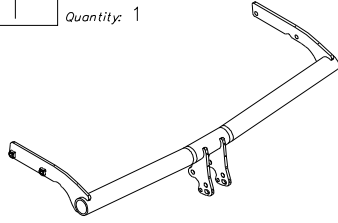
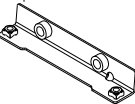
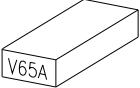
- Indicators
- Tow mirrors

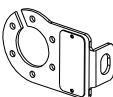
After 1000km of exploitation check all bolts and nuts. The ball of towbar must be always kept clear and conserve with a grease.

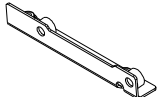
Towbar accessories:

Pos. 1 Name: Main bar Quantity: 1	Pos. 5 Name: Left fish-plate Quantity: 1
	
Pos. 2 Name: Tow ball Quantity: 1	Pos. 6 Name: Bolt 8,8 B Quantity: 4 Dim. : M10x45mm
	
Pos. 3 Name: Socket plate Quantity: 1	Pos. 7 Name: Bolt 8,8 B Quantity: 4 Dim. : M10x25mm
	
Pos. 4 Name: Right fish-plate Quantity: 1	Pos. 8 Name: Plain washer Quantity: 8 Dim. : Ø 10,5 mm
	
	Pos. 9 Name: Spring washer Quantity: 8 Dim. : Ø 10,2 mm
	



PPUH AUTO-HAK Sp.J.

Produkcja Zaczepów Kulowych
Henryk i Zbigniew Nejman
76-200 SŁUPSK ul. Słoneczna 16K
tel/fax (059) 8-414-414; 8-414-413
E-mail: office@autohak.com.pl
www.autohak.com.pl

Towing hitch (without electrical set)

Class: **A50-X** Cat. no. **V65A**

Designed for:

Manufacturer: **NISSAN**

Model: **NOTE**

Type: **5 doors (E11), VAN**

produced since 03.2006 till 09.2013

Technical data:

D-value: 6,9 kN

maximum trailer weight: **1200 kg**

maximum vertical cup load: **50 kg**

Approval number acc. to regulations EKG/ONZ 55.01: **E20-55R-01 4199**

Foreword

This towbar is designed according to rules of safety traffic regulations. The towing hitch is a safety component and can be install only by qualified personnel. Any alteration or conversion of the towing hitch is prohibited and would lead to cancellation of design certification. Remove insulating compound and underseal from vehicle (if present) in the area of the matting surfaces of the towing hitch. The vehicle manufacturer's specifications regarding trailer load and max. vertical cup load are decisive for driving whereat values for the towing hitch cannot be exceeded.

D-value formula:

$$\frac{\text{Max trailer weight [kg]} \times \text{Max vehicle weight [kg]}}{\text{Max trailer weight [kg]} + \text{Max vehicle weight [kg]}} \times \frac{9,81}{1000} = D \text{ [kN]}$$