

## FITTING INSTRUCTION

Clamp mark in acc. with		Cables joining
ISO	PN	
1	L	Left directional lights
2	+	Rear fog lights
3	31	Ground
4	R	Right directional lights
5	58R	Right side parking lights
6	54	Stoptights
7	58L	Left side parking lights

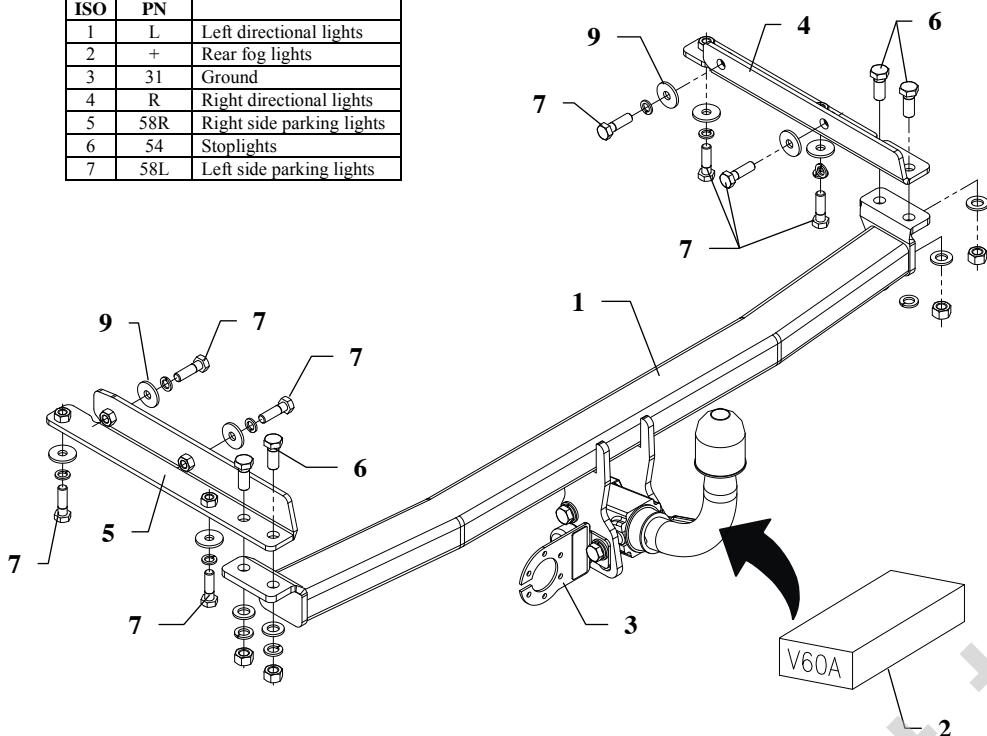

This towbar is designed to assembly in following cars: **NISSAN MICRA, 3/5 doors (K12), except Cabrio** produced since 02.2003 till 12.2010, catalogue no. **V60A** and is prepared to tow trailers max total weight **1300 kg** and max vertical load **75 kg**.

Torque settings for nuts and bolts (8,8):

<b>M6</b> - 11 Nm	<b>M8</b> - 25 Nm	<b>M10</b> - 50 Nm
<b>M12</b> - 87 Nm	<b>M14</b> - 138 Nm	<b>M16</b> - 210 Nm

### From manufacturer

Thank you for buying our product. Their reliability has been confirmed in many tests. Reliability of towbar depends also on correct assembly and right operation. For this reasons we kindly ask to read carefully this instruction and apply to hints.

*The towbar should be install in points described by a car producer.*

## The instruction of the assembly

1. Disassemble the bumper.
2. Get lower the muffler – unfast from last handles.
3. Twist off plugs in chassis members (not used any more).
4. To the left chassis member slip side bracket (pos. 5) in this way, so holes with nuts agree with original holes. Fix loosely with bolts M10x30mm (pos. 7).
5. To the right chassis member slip side bracket (pos. 4) in this way, so holes with nuts agree with original holes. Fix loosely with bolts M10x30mm (pos. 7).
6. Between side brackets put main bar of the towbar (pos. 1) and fix by bolts M12x30mm (pos. 6). Attention! Cut out fragment of plastic profile acc. to figure no. 2
7. Tighten all bolts according to the torque shown in the table.
8. Reassemble the bumper after cut out fragment as shown in fig. 3.
9. Reassemble the muffler.
10. Fix body of the automat and place tow-ball according to supplied instruction.  
Note! Remember to place socket plate (pos. 3) as shown on the drawing 1.
11. Connect electric wires of 7-pole socket according to the instruction of the car. (Recommend to make at authorized service station)
12. Complete paint layer damaged during installation.

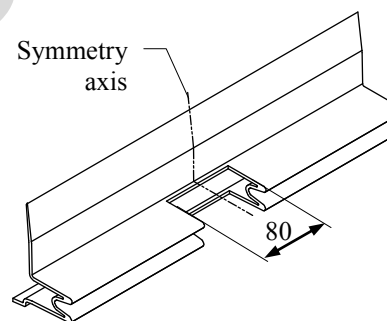

Fig. 2 Plastic profile cut out

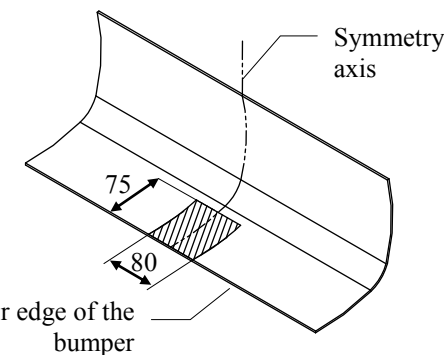

Fig. 3 Bumper cut out

### NOTE

After install the towbar you should get adequate note in registration book (at authorised service station). The car should be equipped with:

- Indicators
- Tow mirrors

After 1000km of exploitation check all bolts and nuts. The ball of towbar must be always kept clear and conserve with a grease.

## Towbar accessories:

Pos. 1	Name: Main bar Quantity: 1	Pos. 5	Name: Left bracket Quantity: 1	Pos. 10	Name: Plain washer Quantity: 4 Dim.: $\varnothing$ 13 mm
Pos. 2	Name: Tow ball Quantity: 1	Pos. 6	Name: Bolt 8,8 B Quantity: 4 Dim.: M12x30mm	Pos. 11	Name: Spring washer Quantity: 4 Dim.: $\varnothing$ 12,2 mm
Pos. 3	Name: Socket plate Quantity: 1	Pos. 8	Name: Nut 8 B Quantity: 4 Dim.: M12		
Pos. 4	Name: Right bracket Quantity: 1	Pos. 9	Name: Washer Quantity: 8 Dim.: $\varnothing$ 30x $\varnothing$ 10x3mm		



**PPUH AUTO-HAK Sp.J.**

Produkcja Zaczepów Kulowych  
Henryk i Zbigniew Nejman  
76-200 SŁUPSK ul. Słoneczna 16K  
tel/fax (059) 8-414-414; 8-414-413  
E-mail: [office@autohak.com.pl](mailto:office@autohak.com.pl)  
[www.autohak.com.pl](http://www.autohak.com.pl)

## Towing hitch (without electrical set)

Class: **A50-X** Cat. no. **V60A**  
Designed for:  
Manufacturer: **NISSAN**  
Model: **MICRA**  
Type: **3/5 doors (K12), except Cabrio**  
produced since 02.2003 till 12.2010

Technical data:  
**D-value: 6,78 kN**  
maximum trailer weight: **1300 kg**  
maximum vertical cup load: **75 kg**

**Approval number according to Directive 94/20/EC: e20\*94/20\*1044\*00**

## Foreword

This towbar is designed according to rules of safety traffic regulations. The towing hitch is a safety component and can be install only by qualified personnel. Any alteration or conversion of the towing hitch is prohibited and would lead to cancellation of design certification. Remove insulating compound and underseal from vehicle (if present) in the area of the matting surfaces of the towing hitch. The vehicle manufacturer's specifications regarding trailer load and max. vertical cup load are decisive for driving whereat values for the towing hitch cannot be exceeded.

*D-value formula:*

$$\frac{\text{Max trailer weight [kg]} \times \text{Max vehicle weight [kg]}}{\text{Max trailer weight [kg]} + \text{Max vehicle weight [kg]}} \times \frac{9,81}{1000} = D \text{ [kN]}$$