

AUTO-HAK Sp. z o.o.

ul. Słoneczna 16K 76-200 SŁUPSK
POLAND

tel/fax +48 59 8 414 414; +48 59 8 414 413

e-mail: office@autohak.com.pl

www.autohak.com.pl



AUTO-HAK

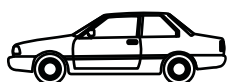

KIA NIRO 5D, Hybryda/Hybrid

Cat. no:

T74A



2016 → 05.2019



E20-55R-01 4922



8,04 kN



R=1300 kg



S=100 kg



2h



TYPE:
•C5P11/D61AY1
•C5P11/D61BY1

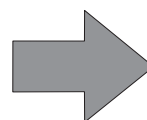

TYPE:
•C5P11/D61AZ1
•C5P11/D61BZ1



M6 - 8,5 Nm
M10 - 41 Nm
M14 - 112 Nm

M8 - 20 Nm
M12 - 70 Nm
M16 - 170 Nm









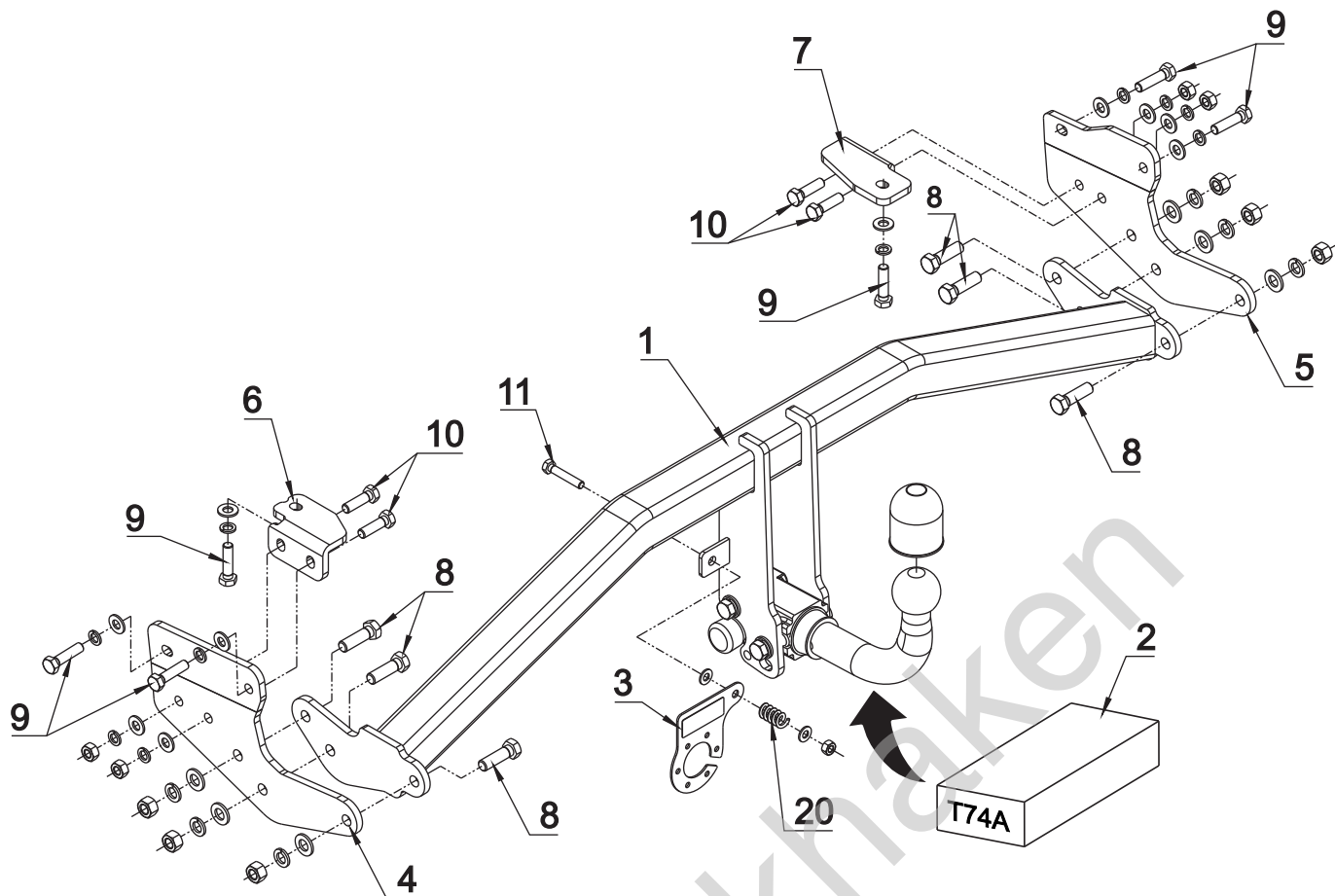

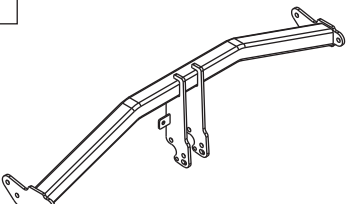

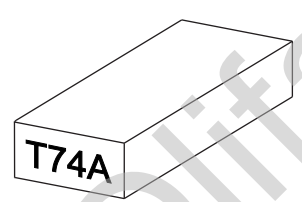

0 km



1000 km

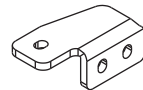

1		x 1		8	M12x40	x 6
2	 Art.nr-KL1T74A	x 1		9	M10x1,25x40	x 6
				10	M10x35	x 4
				11	M8x45	x 1
				12	M12	x 6
				13	M10	x 4
3	 Art.nr-BL1T74A	x 1		14	M8	x 1
				15	∅ 13	x 6
				16	∅ 10.5	x 10
4		x 1		17	∅ 8.4	x 2
				18	∅ 12.2	x 6
5		x 1		19	∅ 10.2	x 10
				20		x 1
6		x 1				
7		x 1				

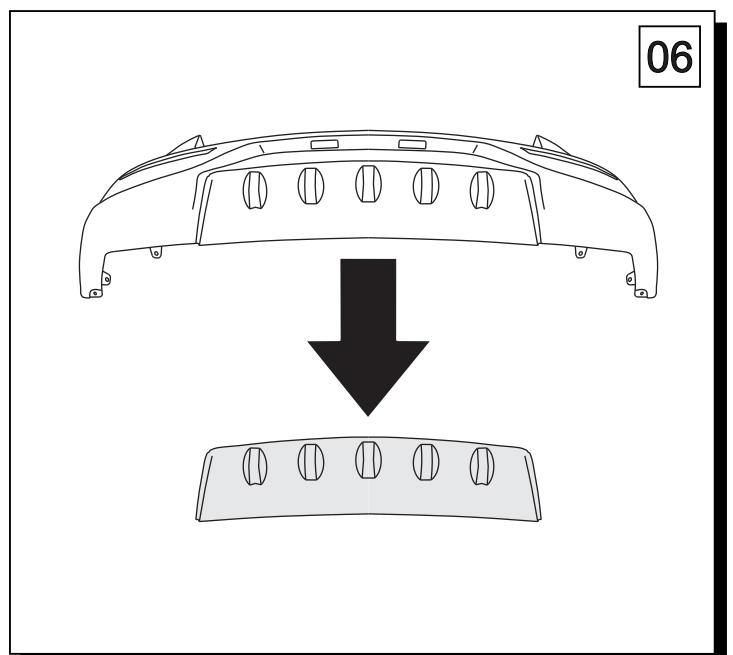
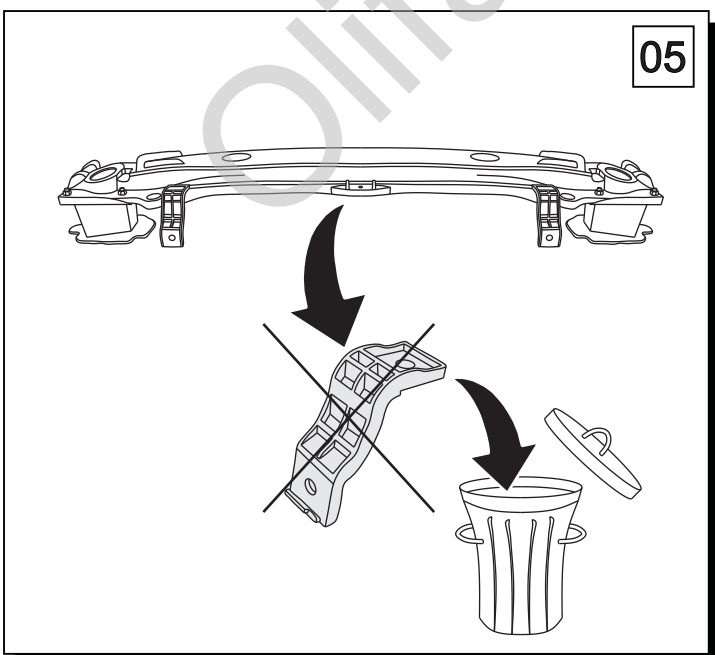
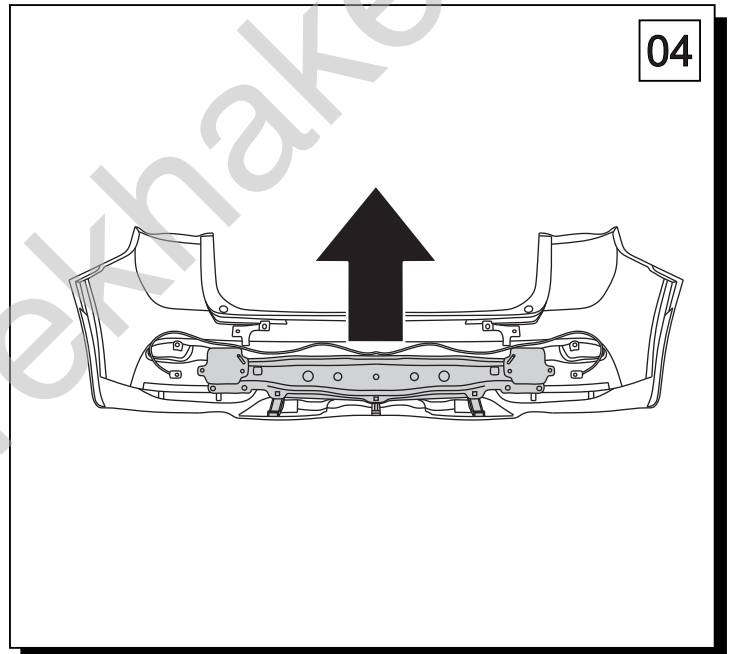
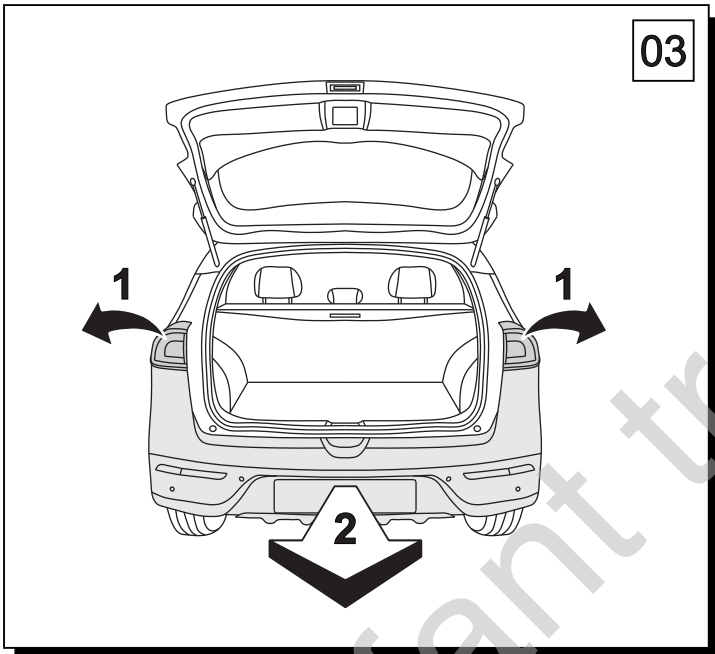
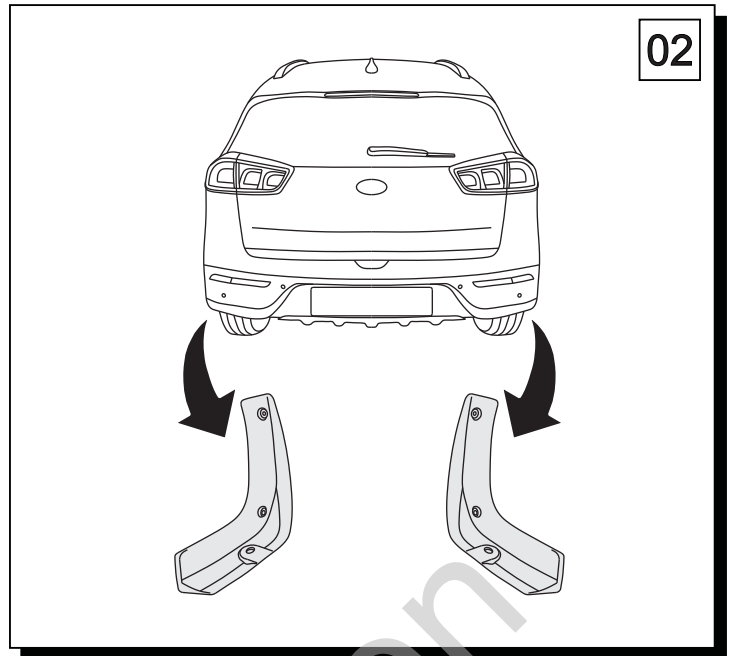
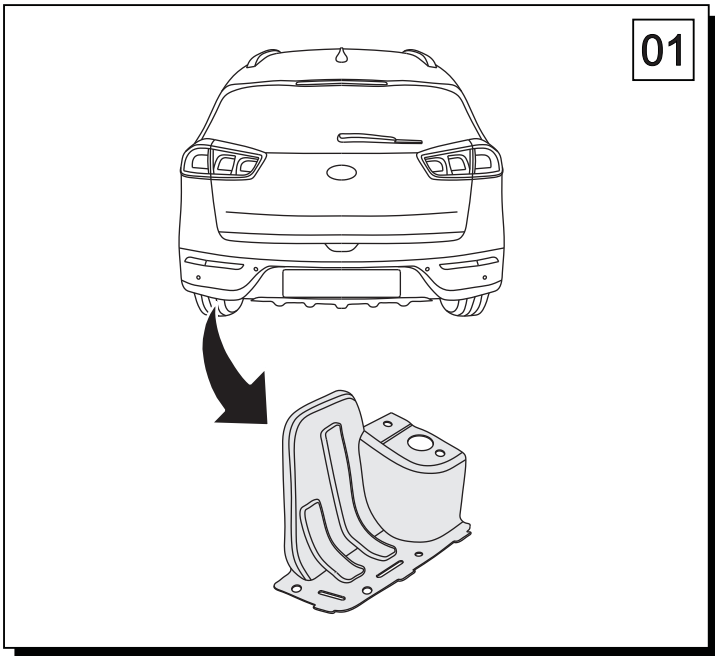

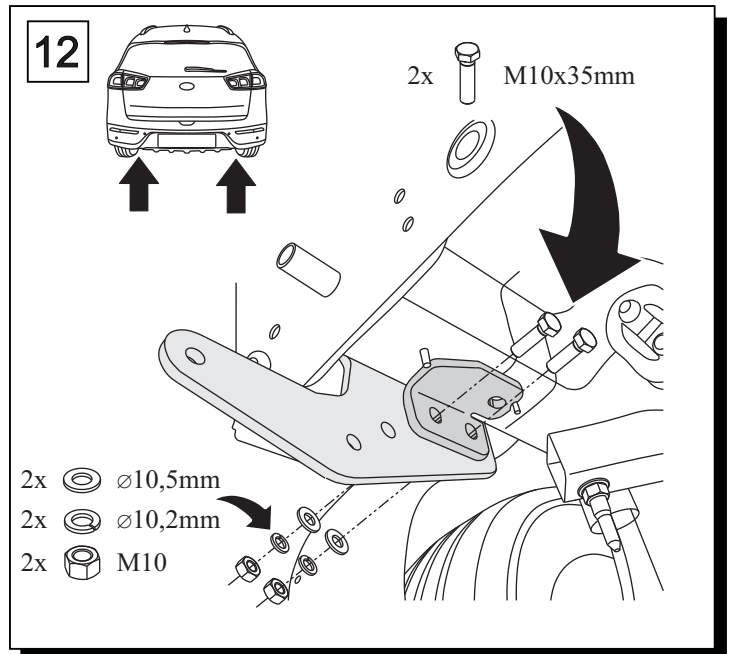
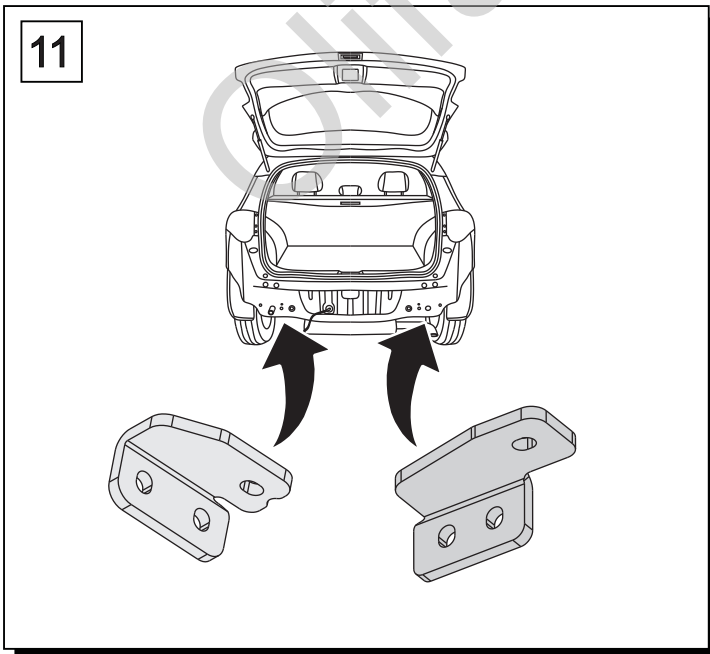
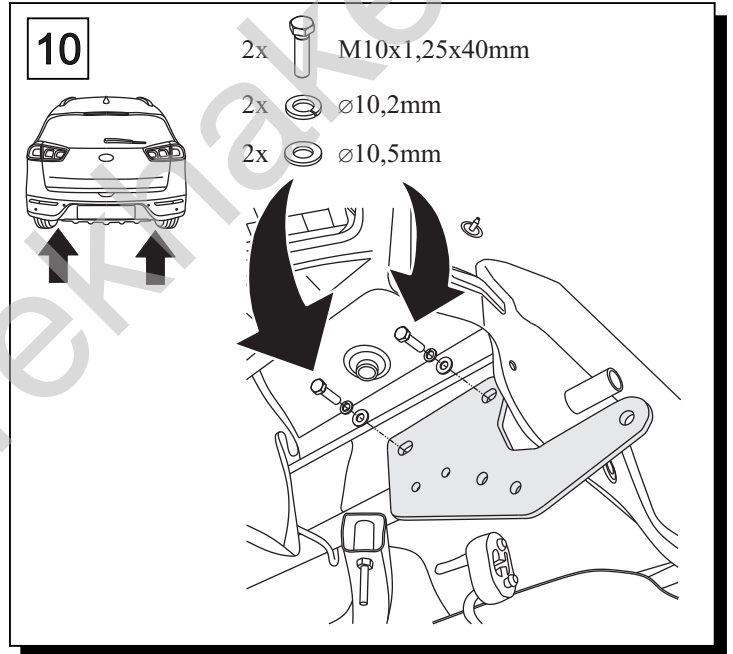
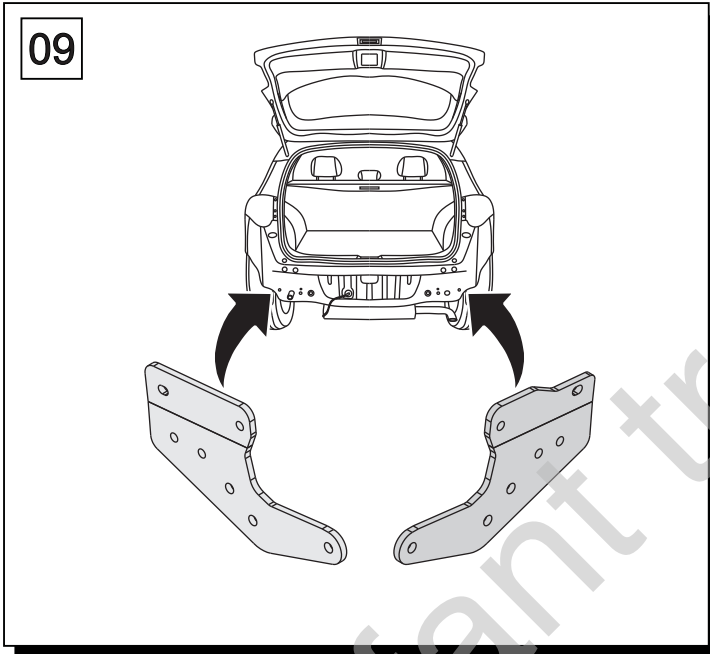
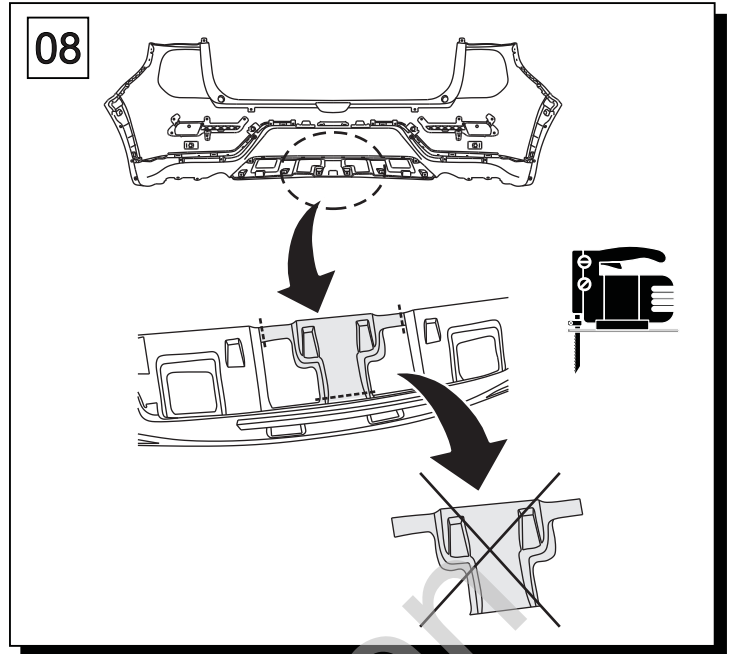
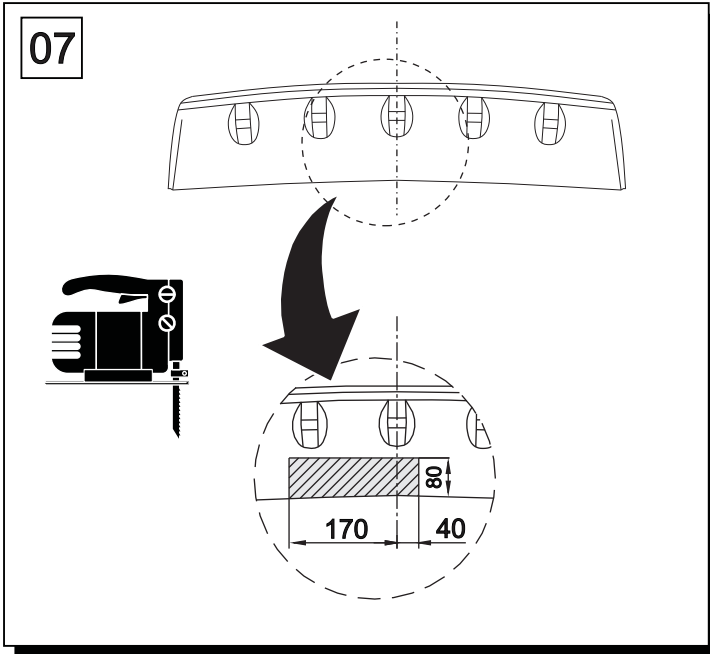

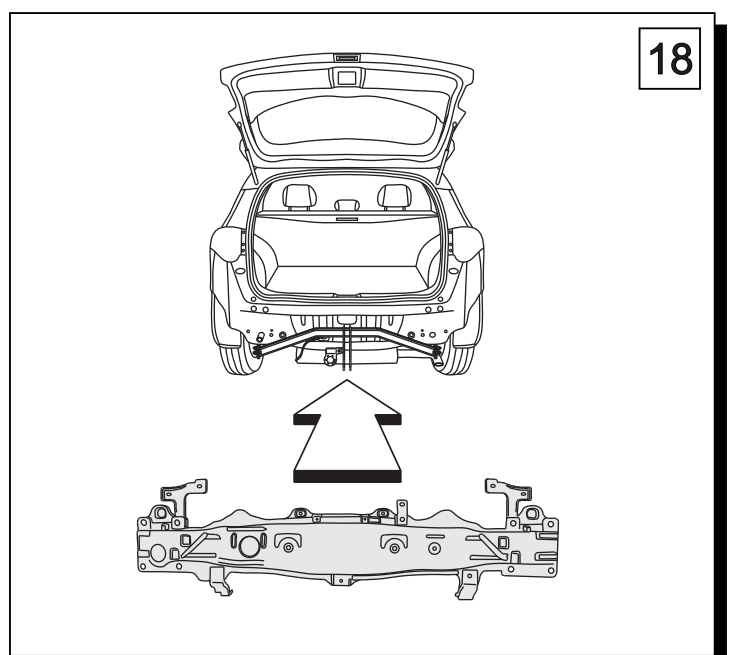
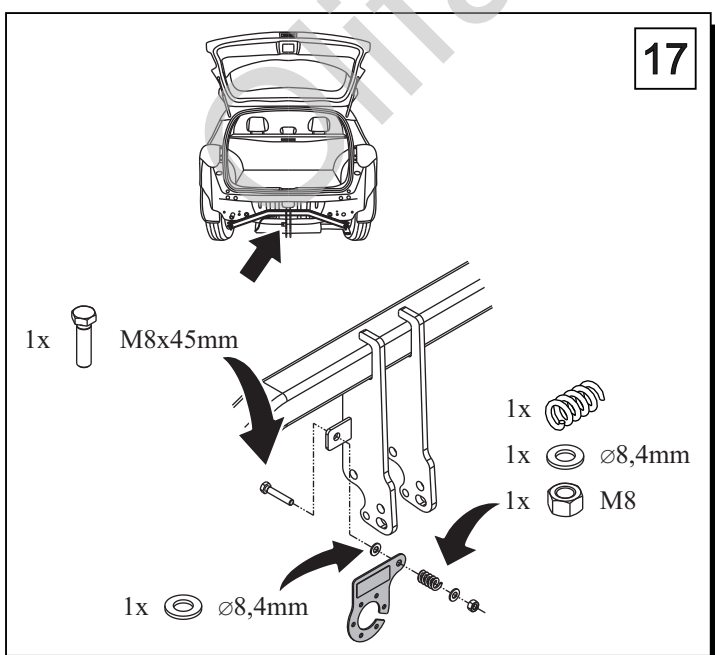
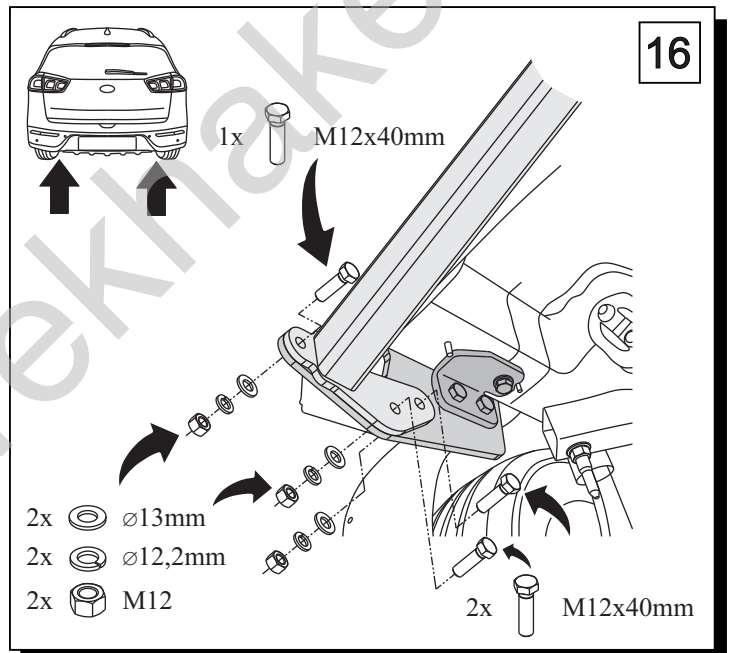
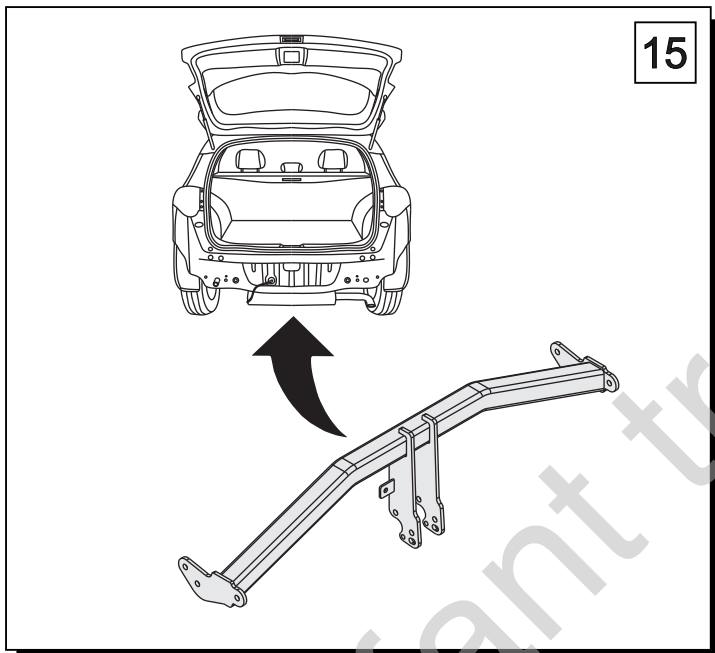
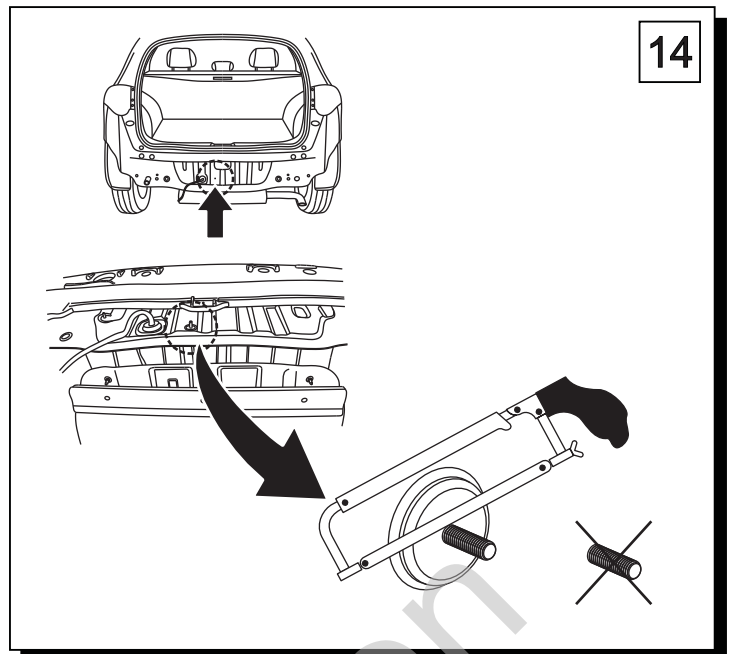
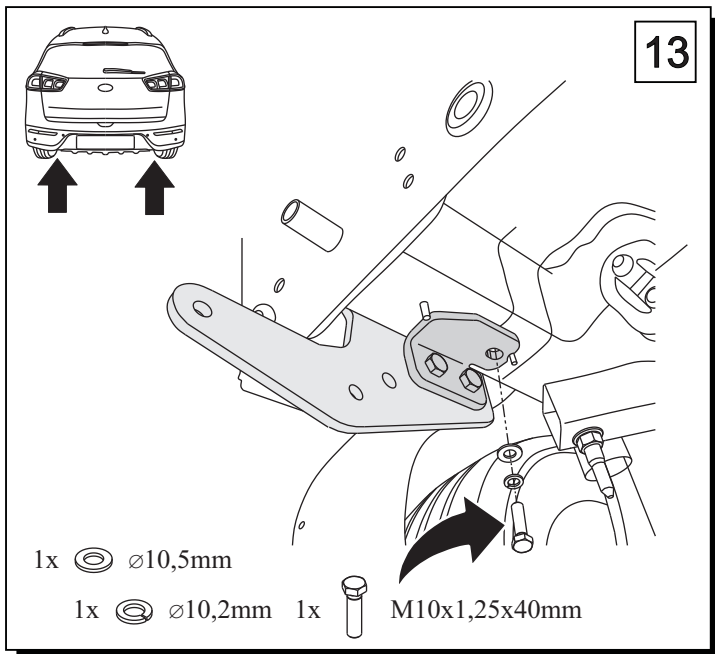

19

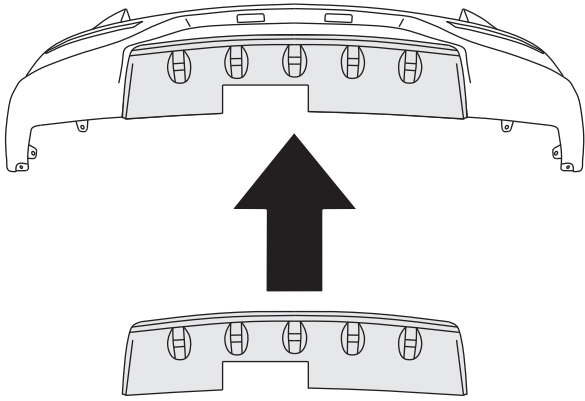

20

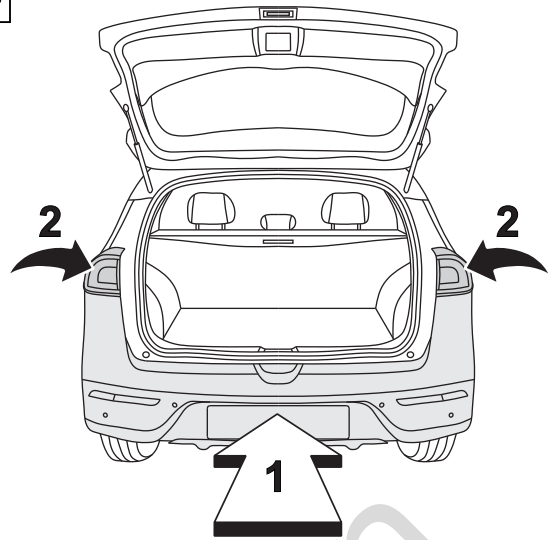

21

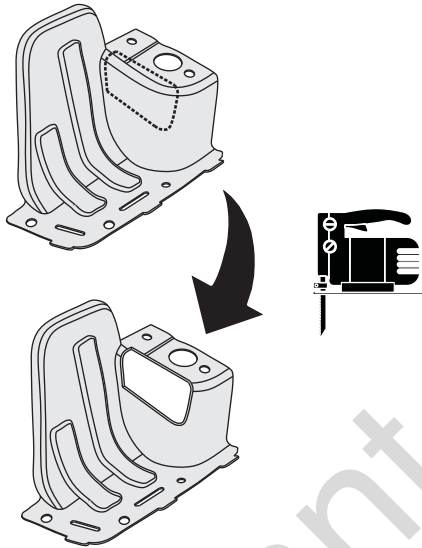

22

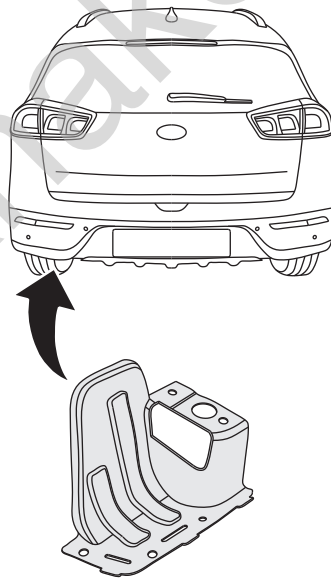

23

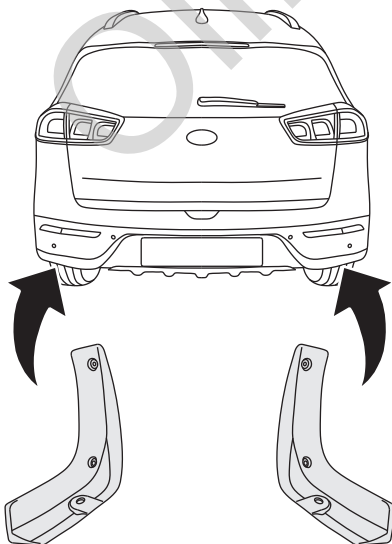

24

