

# PPUH AUTO-HAK Sp.J.

Henryk i Zbigniew Nejman  
ul. Słoneczna 16K 76-200 SŁUPSK  
POLAND

tel/fax +48 59 8 414 414; +48 59 8 414 413

e-mail: [office@autohak.com.pl](mailto:office@autohak.com.pl)

[www.autohak.com.pl](http://www.autohak.com.pl)



**AUTO-HAK**



**KIA SORENTO**  
5D, (XM)

Cat. no:

**T59A**



11.2009 → 10.2012

**e20**

e20\*94/20\*1231\*00

**D**

12,64 kN



**2h**



R=2500 kg



S=100



**20,4 kg**

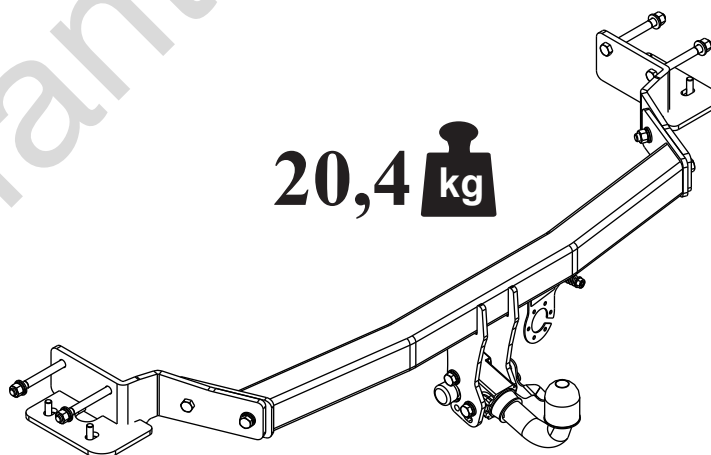

M6 - 11 Nm  
M10 - 50 Nm  
M14 - 138 Nm

M8 - 25 Nm  
M12 - 87 Nm  
M16 - 210 Nm









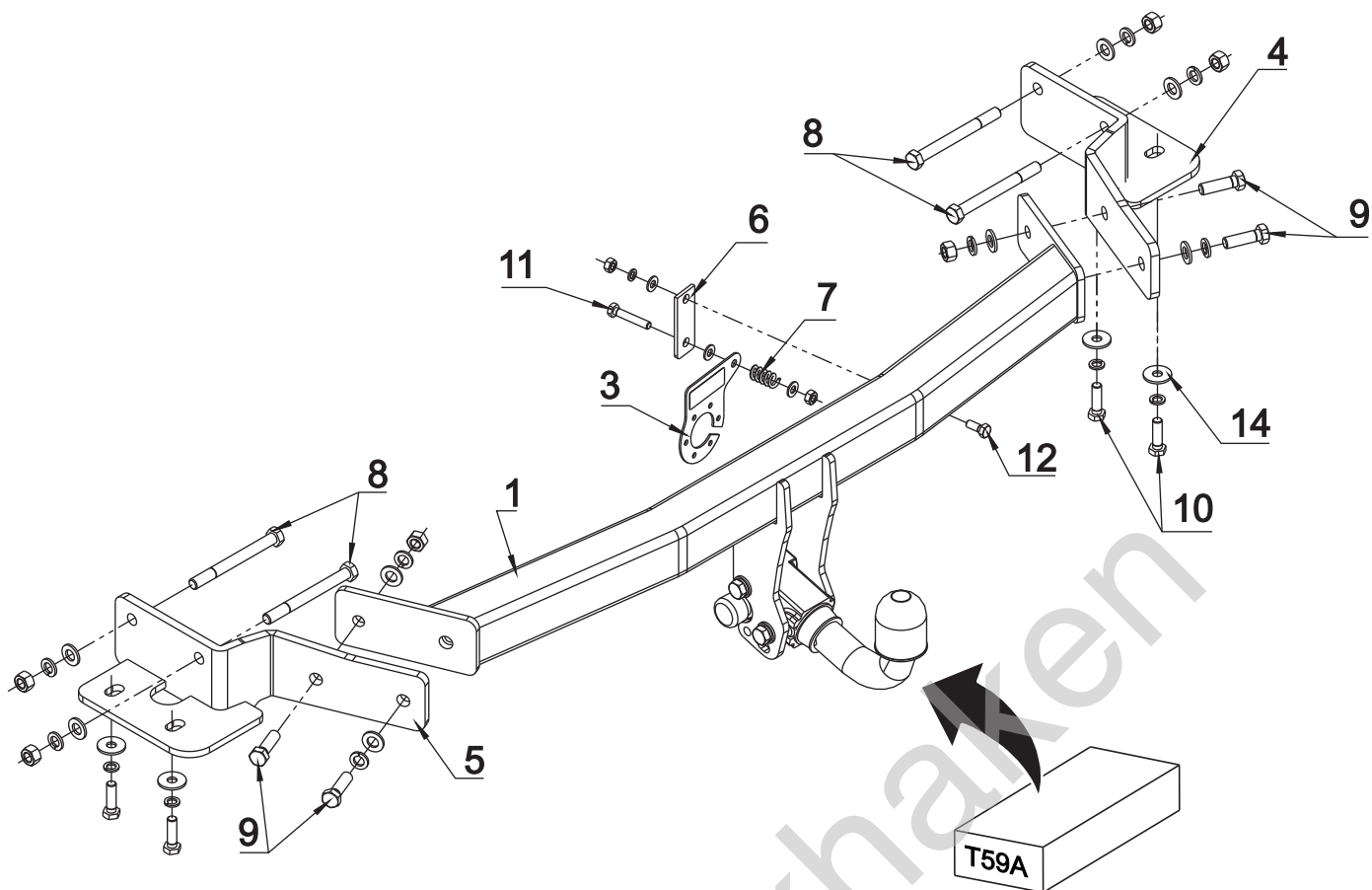

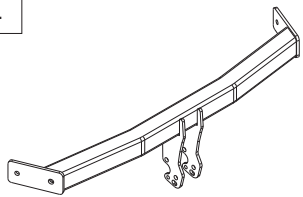
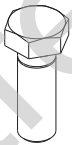
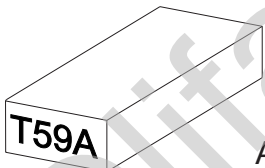
0 km →

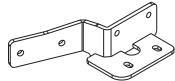

1000 km

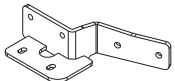
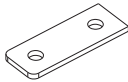

	x 1		8	M12x120	x 4
			9	M12x40	x 4
			10	M10x1,25x35	x 4
			11	M8x45	x 1
			12	M8x20	x 1
			13	∅ 13	x 8
 Art.nr-KL1T59A	x 1		14	∅ 30x∅10.5x2.5 10 (DIN 9021)	x 4
			15	∅ 8.5	x 3
 Art.nr-BL1T59A	x 1		16	∅ 12.2	x 8
			17	∅ 10.2	x 4
	x 1		18	∅ 8.2	x 1
	x 1		19	M12	x 6
	x 1		20	M8	x 2
				x 1	

