

## FITTING INSTRUCTION

Clamp mark in acc. with		Cables joining
ISO	PN	
1	L	Left directional lights
2	+	Rear fog lights
3	31	Ground
4	R	Right directional lights
5	58R	Right side parking lights
6	54	Stoplights
7	58L	Left side parking lights

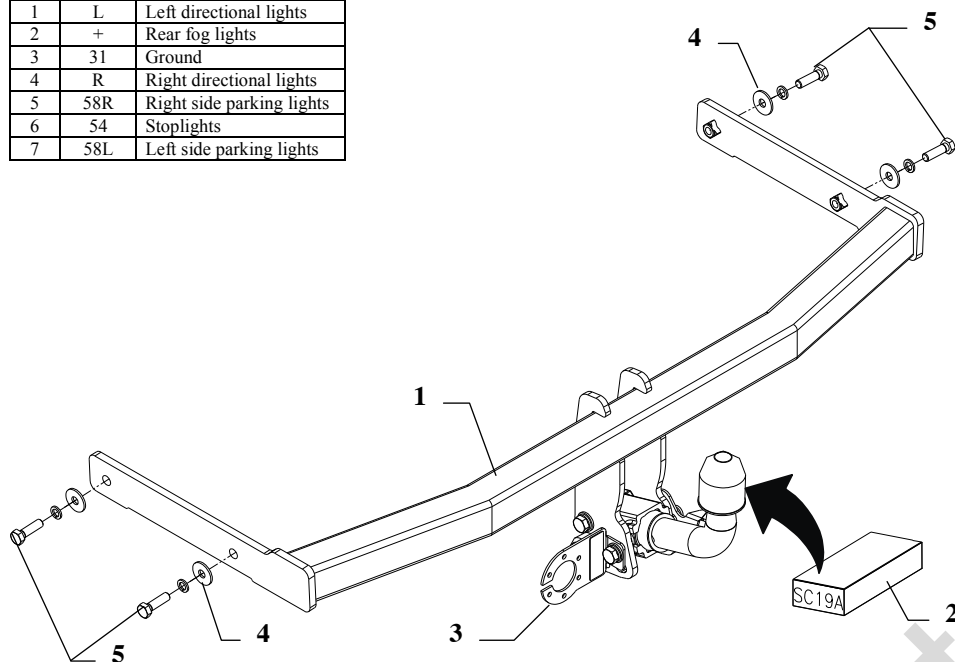

This towbar is designed to assembly in following cars:  
**SEAT TOLEDO, 4 doors (1M2)**, produced since 02.1999 till 11.2004,  
 catalogue no. **SC19A** and is prepared to tow trailers max total weight **1600 kg** and max vertical load **75 kg**.

### *From manufacturer*

Thank you for buying our product. Their reliability has been confirmed in many tests. Reliability of towbar depends also on correct assembly and right operation. For this reasons we kindly ask to read carefully this instruction and apply to hints.

*The towbar should be install in points described by a car producer.*

## The instruction of the assembly

1. Disassemble the bumper and next unscrew its factory metal part (not used any more).
2. From below find two holes from side chassis members (under conservation coat).
3. Slip the main bar of the towbar (pos. 1) to chassis members and fix using bolts 10x35mm (pos. 5). Remember about big washers (pos. 4).
4. Assemble the bumper after cut out one fragment (use template).
5. Fix body of the automat and place tow-ball according to supplied instruction. Note! Remember to place socket plate (pos. 3) as shown on the drawing 1.
6. Connect electric wires of 7-poles socket according to the instruction of the car. (Recommend to make at authorized service station).
7. Complete paint layer damaged during installation.

Torque settings for nuts and bolts (8,8):

<b>M6</b> - 11 Nm	<b>M8</b> - 25 Nm	<b>M10</b> - 50 Nm
<b>M12</b> - 87 Nm	<b>M14</b> - 138 Nm	<b>M16</b> - 210 Nm

## NOTE

After install the towbar you should get adequate note in registration book (at authorised service station). The car should be equipped with:

- Indicators
- Tow mirrors

After 1000km of exploitation check all bolts and nuts. The ball of towbar must be always kept clear and conserve with a grease.

## Towbar accessories:

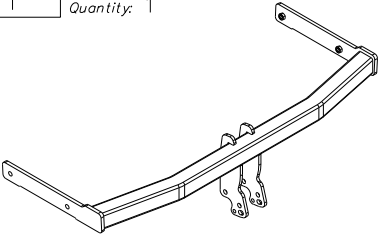
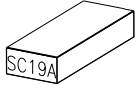
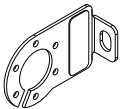
Pos. 1	Name: Main bar Quantity: 1	Pos. 4	Name: Washer Quantity: 4 Dim. : $\varnothing 37 \times \varnothing 13 \times 3 \text{mm}$
		Pos. 5	Name: Bolt 8,8 B Quantity: 4 Dim. : M10x35mm
		Pos. 6	Name: Spring washer Quantity: 4 Dim. : $\varnothing 10,2 \text{ mm}$
Pos. 2	Name: Tow ball Quantity: 1		
Pos. 3	Name: Socket plate Quantity: 1		



## PPUH AUTO-HAK Sp.J.

Produkcja Zaczepów Kulowych  
Henryk & Zbigniew Nejman  
76-200 SŁUPSK ul. Słoneczna 16K  
tel/fax (059) 8-414-414; 8-414-413  
E-mail: [office@autohak.com.pl](mailto:office@autohak.com.pl)  
[www.autohak.com.pl](http://www.autohak.com.pl)

### Towing hitch (without electrical set)

Class: **A50-X** Cat. no. **SC19A**

Designed for:

Manufacturer: **SEAT**

Model: **TOLEDO**

Type: **4 doors (1M2)**

produced since 02.1999 till 11.2004

Technical data:

**D-value: 8,62 kN**

maximum trailer weight: **1600 kg**

maximum vertical cup load: **75 kg**

Approval number according to Directive 94/20/EC: **e20\*94/20\*1133\*00**

### Foreword

This towbar is designed according to rules of safety traffic regulations. The towing hitch is a safety component and can be install only by qualified personnel. Any alteration or conversion of the towing hitch is prohibited and would lead to cancellation of design certification. Remove insulating compound and underseal from vehicle (if present) in the area of the matting surfaces of the towing hitch.

The vehicle manufacturer's specifications regarding trailer load and max. vertical cup load are decisive for driving whereat values for the towing hitch cannot be exceeded.

*D-value formula:*

$$\frac{\text{Max trailer weight [kg]} \times \text{Max vehicle weight [kg]}}{\text{Max trailer weight [kg]} + \text{Max vehicle weight [kg]}} \times \frac{9,81}{1000} = D \text{ [kN]}$$

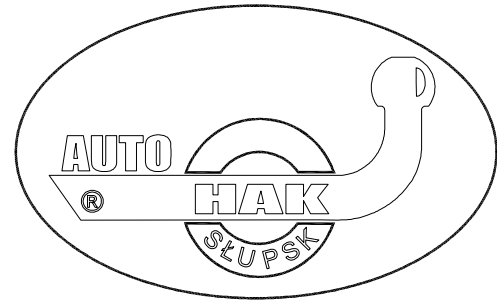

Wyciąć  
Cut out  
Herausschneiden

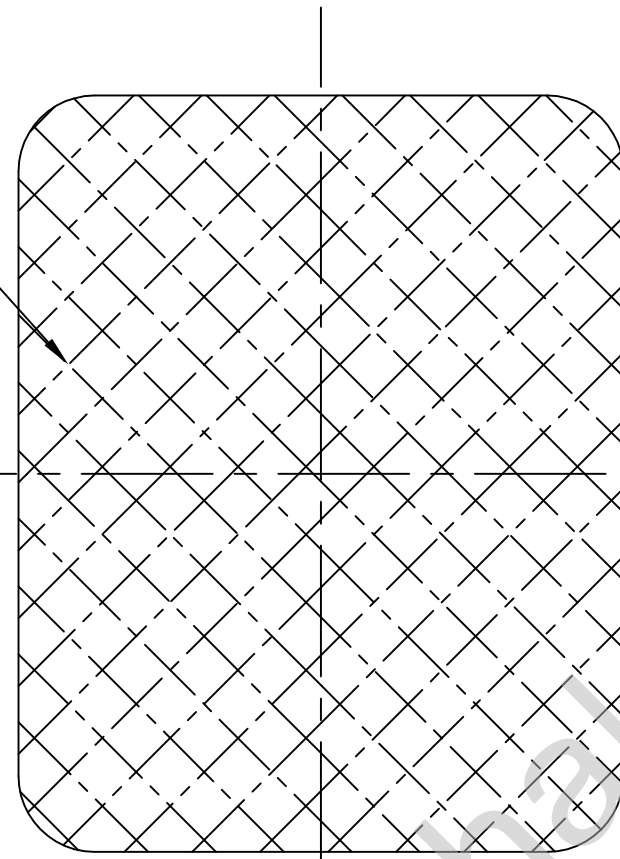

Linia brzegowa zderzaka  
Bumper edge  
Unterkante

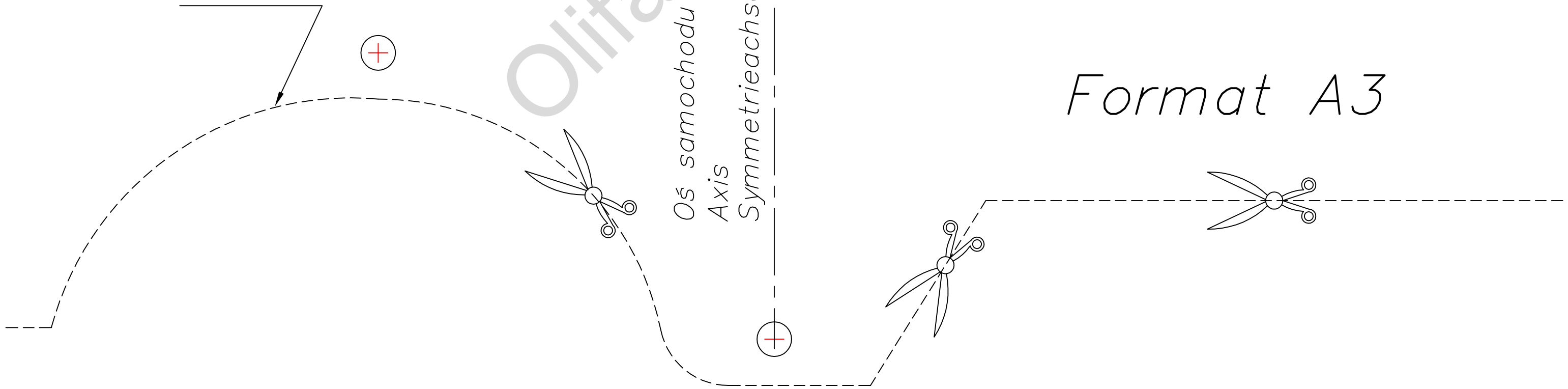

SC19, SC19A

Seat Toledo 4D

⌚ 04.1999 → 11.2004

Format A3

Olifant trekhaken

Oś samochodu  
Axis  
Symmetrieachse