

AUTO-HAK Sp. z o.o.

ul. Słoneczna 16K 76-200 SŁUPSK
POLAND

tel/fax +48 59 8 414 414; +48 59 8 414 413

e-mail: office@autohak.com.pl

www.autohak.com.pl



AUTO-HAK

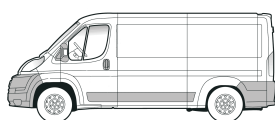

**FIAT DUCATO
CITROEN JUMPER
PEUGEOT BOXER**

(L1, L2, L3) zabudowany-błaszak
06.2006 → 01.2011
02.2011 → 05.2014
06.2014 →

Nr kat.

R60

OPEL MOVANO C (L1, L2, L3) zabudowany-błaszak
01.2022 →



1,5h

Hak przystosowany do montażu stopnia firmy Auto-Hak

E20

E20-55R-01 5095

D

16,9 kN



R=3100 kg



S=150 kg

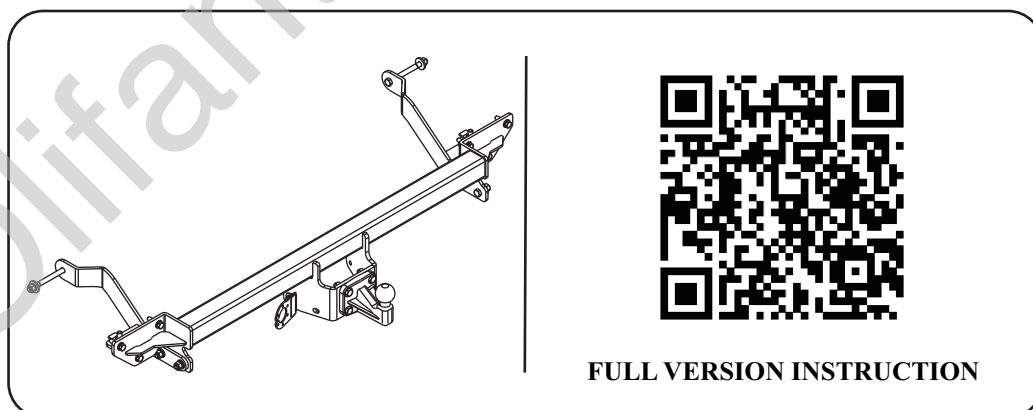

FULL VERSION INSTRUCTION



śruba	Nm	M6	M8	M10	M12	M14	M16
klasa 8.8		9,9	24	48	83	132	200
klasa 10.9		14	34	67	117	185	285









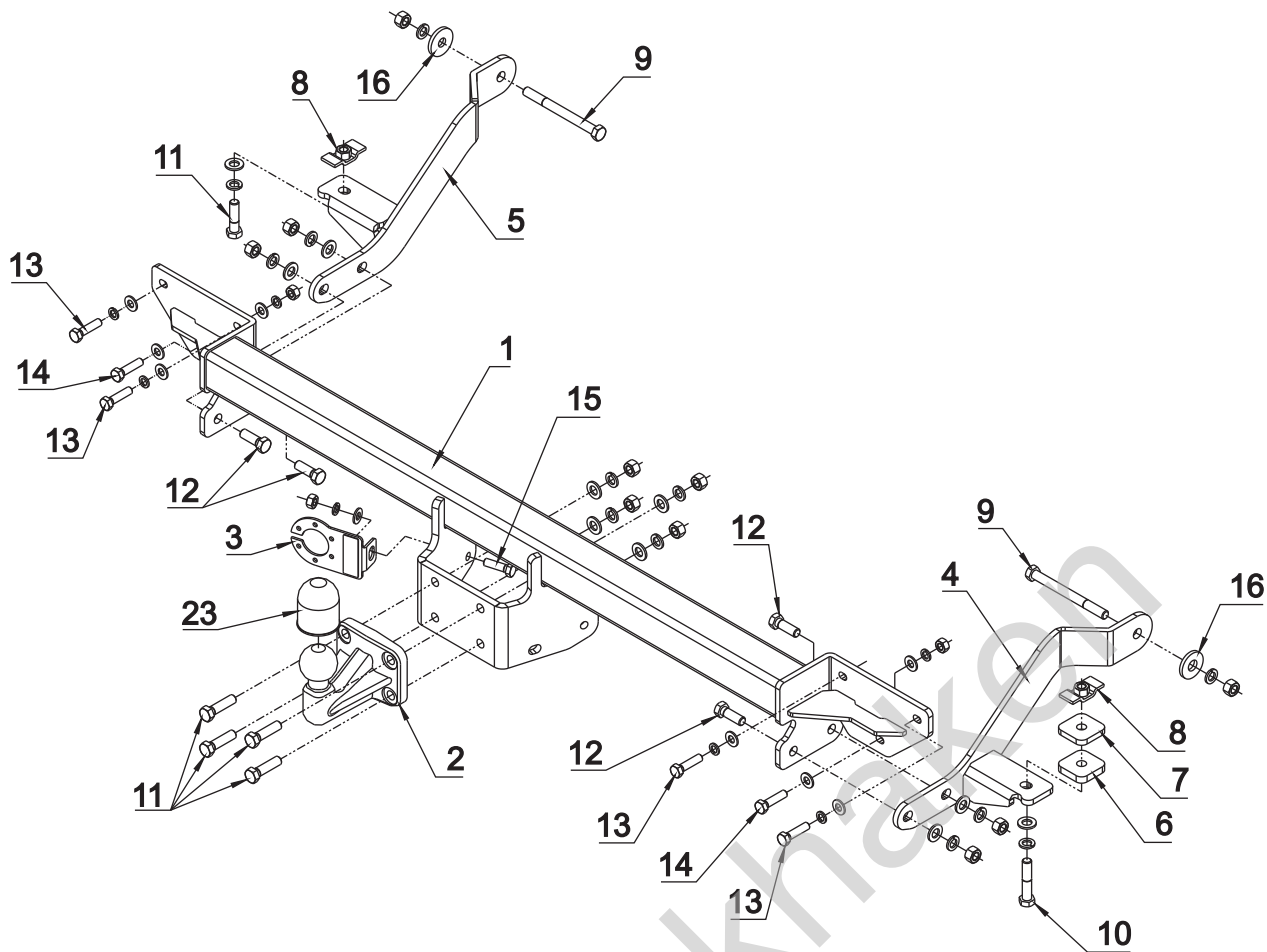

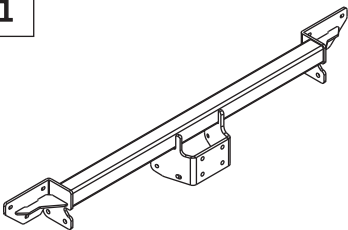

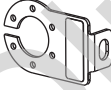
0 km →

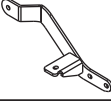

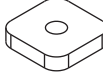
1000 km

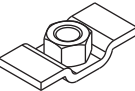

1		x 1		9 M12x130	x 2
				10 M12x60	x 1
				11 M12x45	x 5
				12 M12x35	x 4
				13 M10x1.25x40	x 4
2		x 1		14 M10x40	x 2
	Art.nr-KL1R60			15 M10x30	x 1
3		x 1		16 ϕ 37x ϕ 13x3 13 (DIN 9021)	x 2
	Art.nr-BL1R60			17 ϕ 13	x 10
4		x 1		18 ϕ 10.5	x 9
5		x 1		19 ϕ 12.2	x 12
				20 ϕ 10.2	x 7
6		x 1		21 M12	x 10
	48x48x10mm			22 M10	x 3
7		x 1	23 		x 1
	48x48x8mm				
8		x 2			

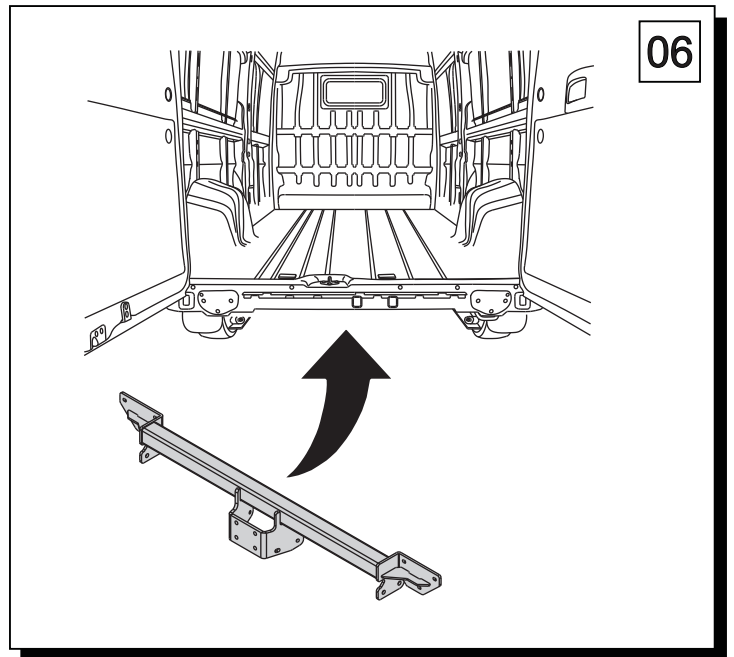
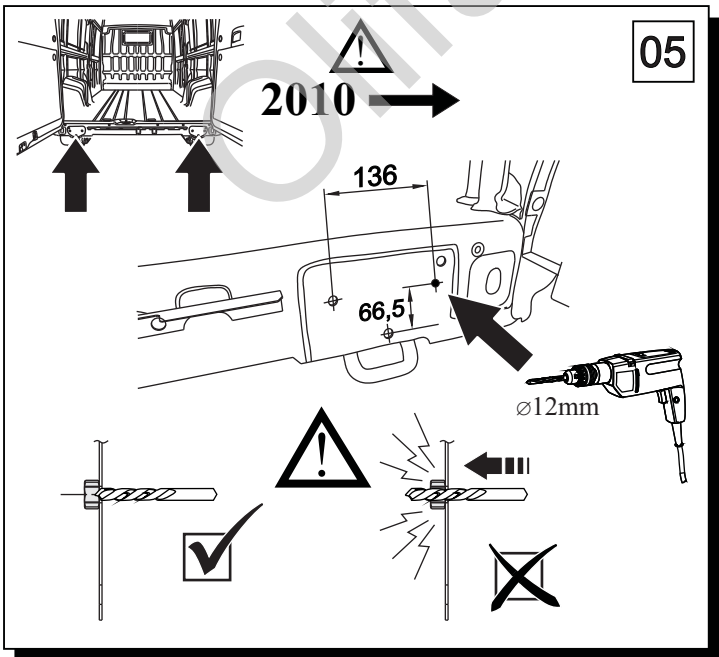
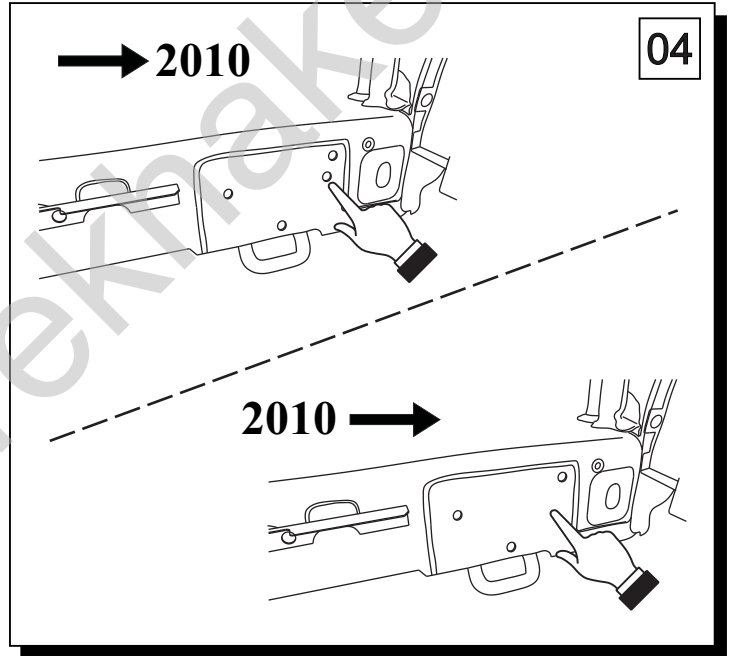
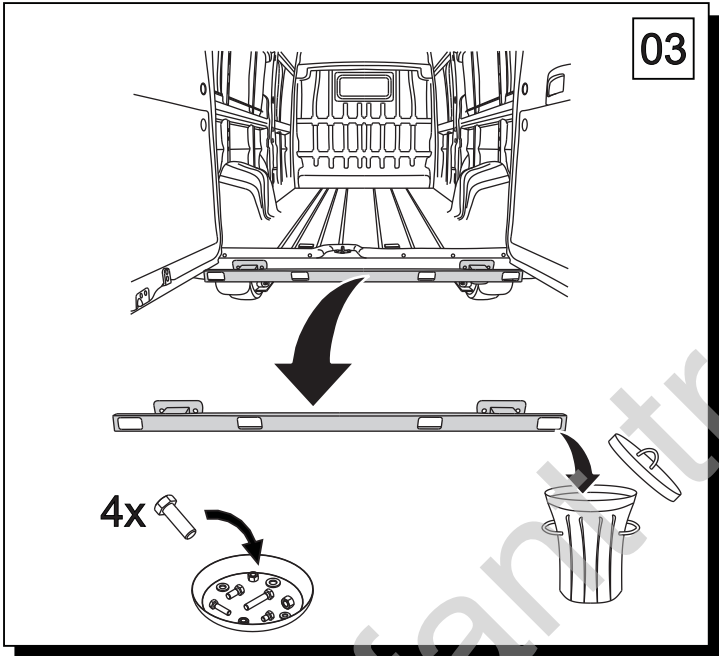
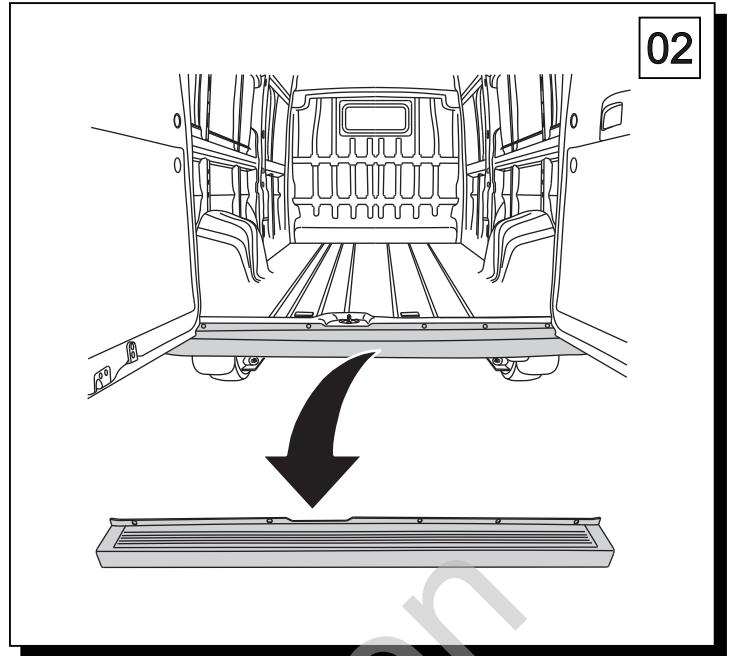
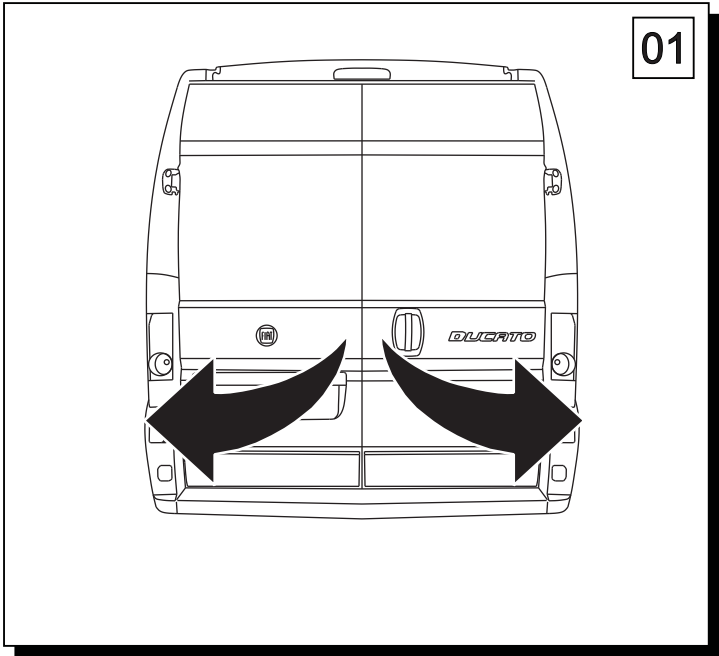

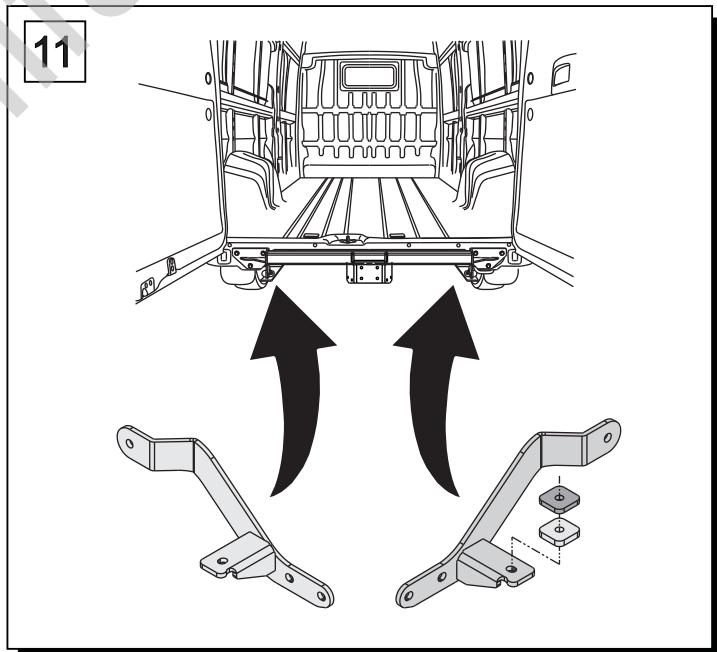
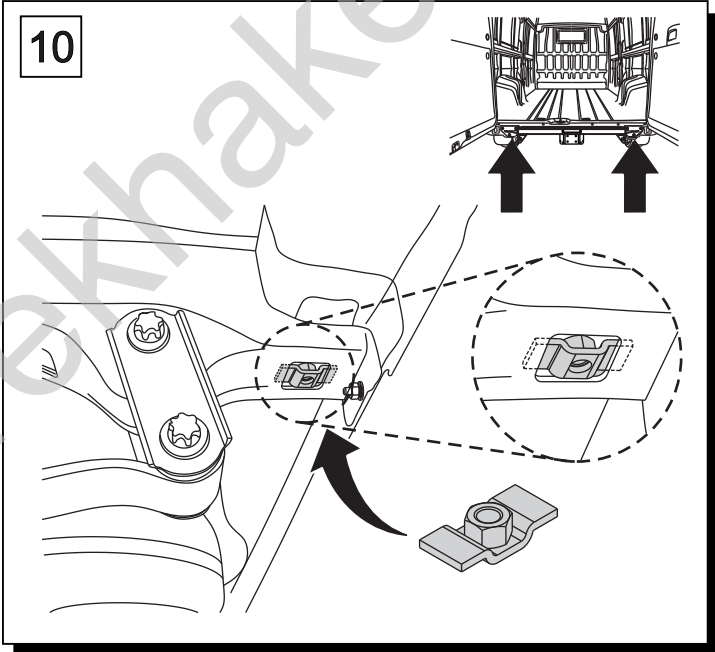
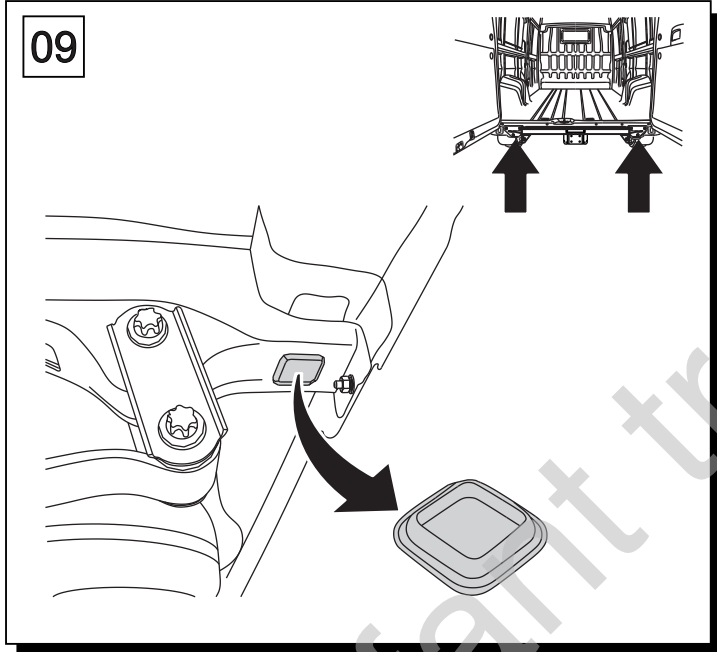
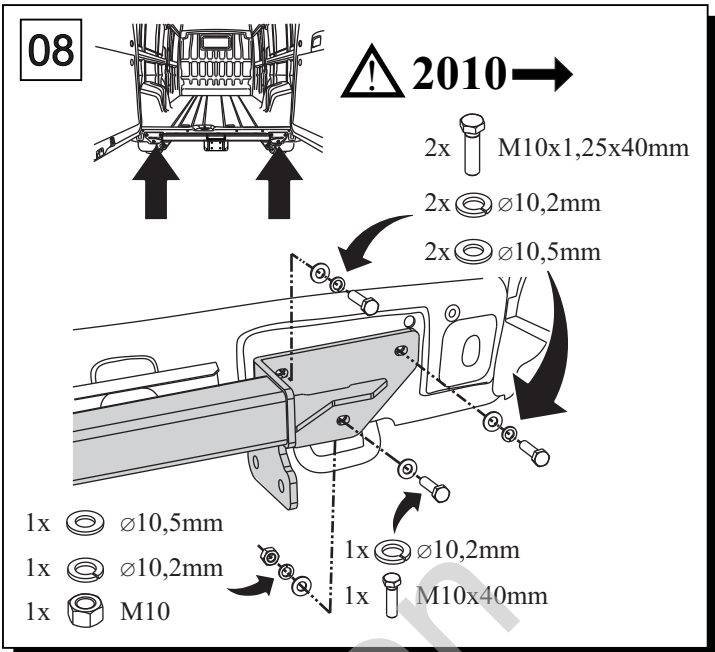
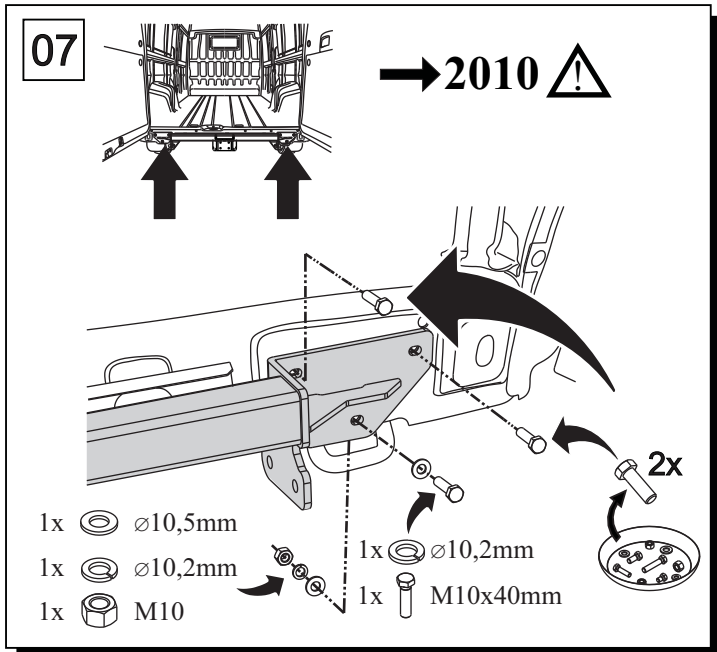

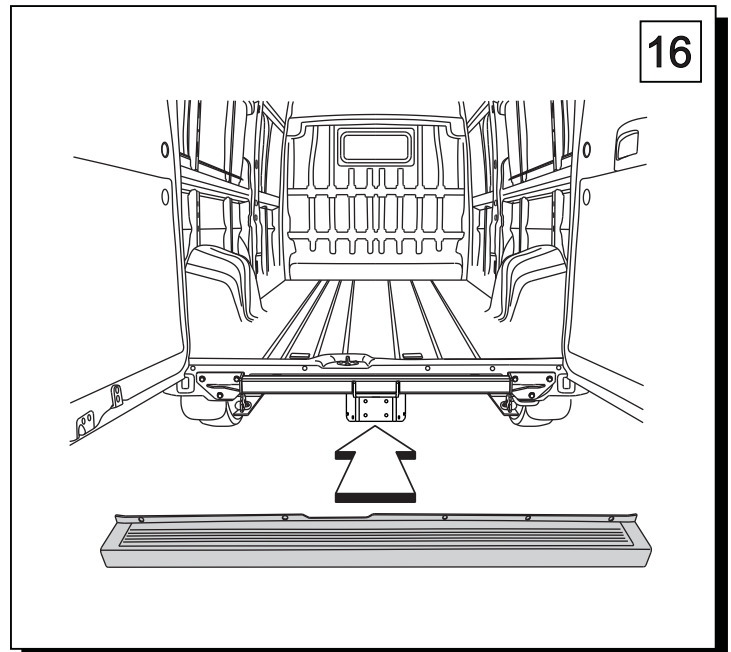
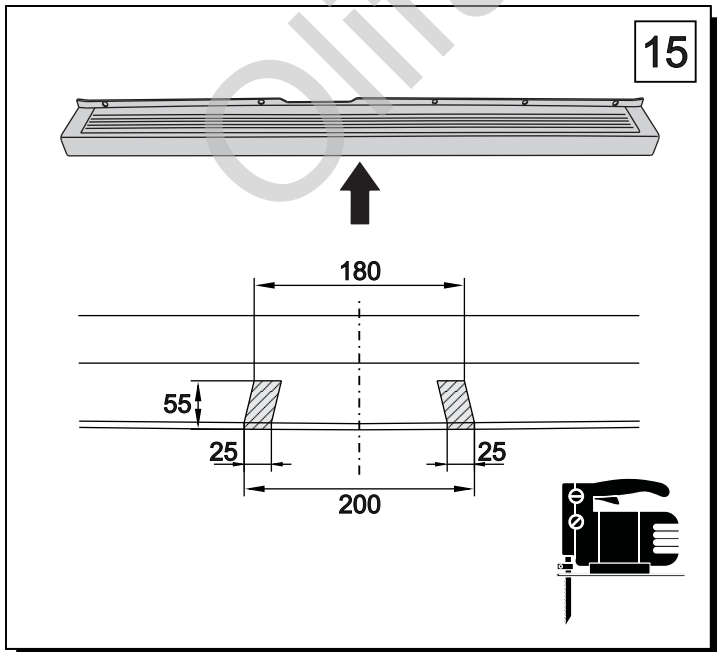
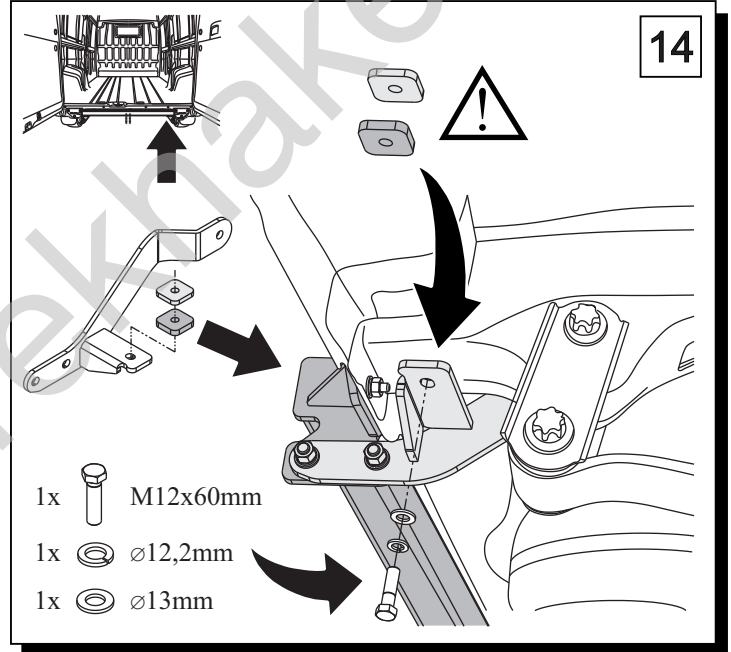
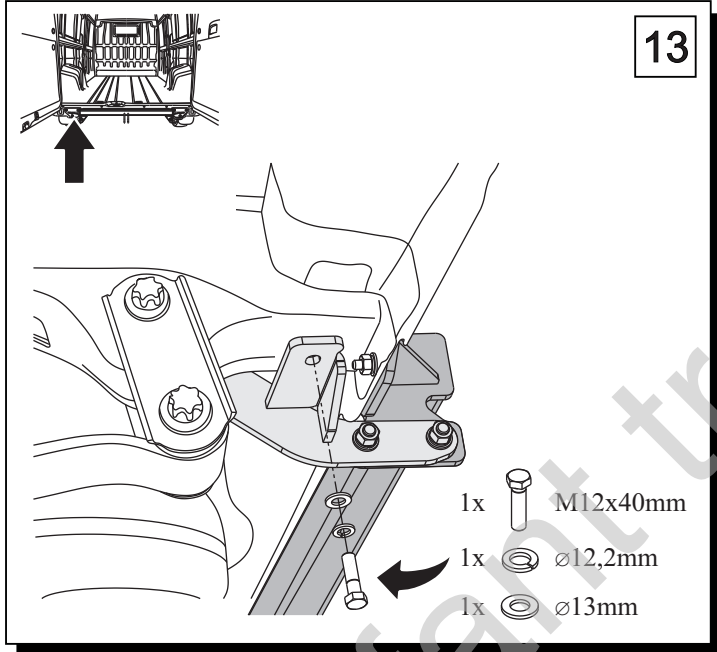
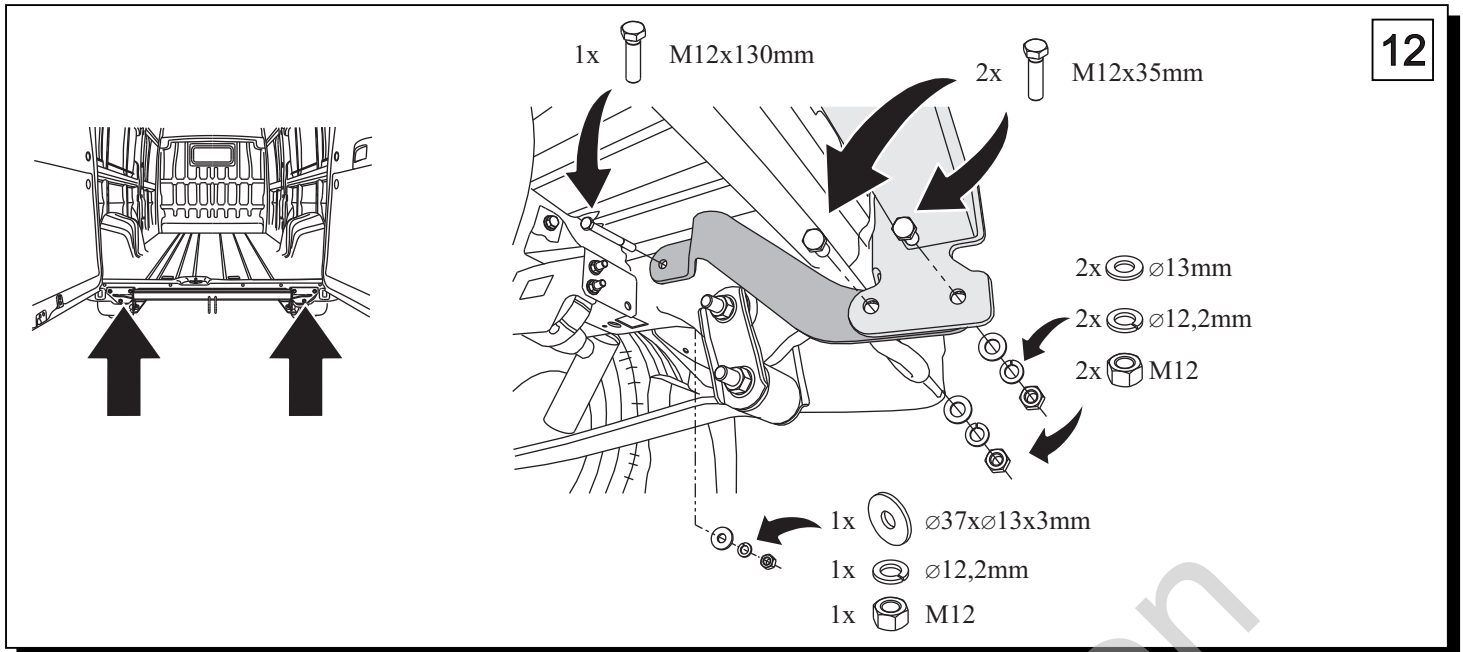

17

1x  $\varnothing 10,2\text{mm}$

1x  $\varnothing 10,5\text{mm}$

1x  M10

1x  M10x30mm

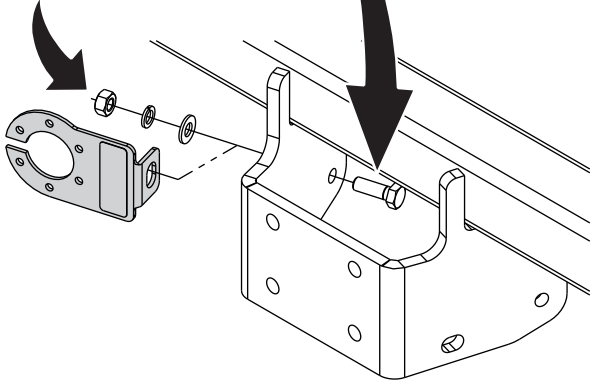

18

4x  $\varnothing 12,2\text{mm}$

4x  $\varnothing 13\text{mm}$

4x  M12



4x  M12x45mm

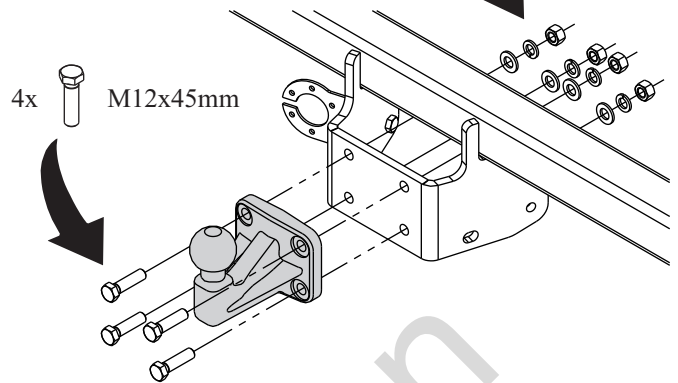

Olifant trekhaken