

AUTO-HAK Sp. z o.o.

ul. Słoneczna 16K 76-200 SŁUPSK
POLAND

tel/fax +48 59 8 414 414; +48 59 8 414 413

e-mail: office@autohak.com.pl

www.autohak.com.pl



AUTO-HAK

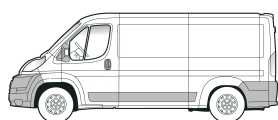

**FIAT DUCATO
CITROEN JUMPER
PEUGEOT BOXER**

(L4, L5) zabudowany-blaszak

06.2006 → 01.2011



02.2011 → 05.2014

06.2014 →

Nr kat.

R42A

OPEL MOVANO C (L4, L5) zabudowany-blaszak



01.2022 →



1,5h

e20

e20*94/20*0495*00



D

16,13 kN



kg

R=3100 kg



S=124 kg

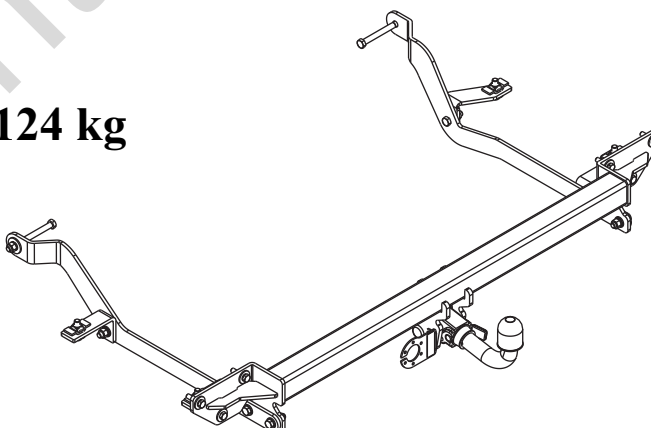

śruba	Nm	M6	M8	M10	M12	M14	M16
klasa 8.8		9,9	24	48	83	132	200
klasa 10.9		14	34	67	117	185	285



0 km →



1000 km

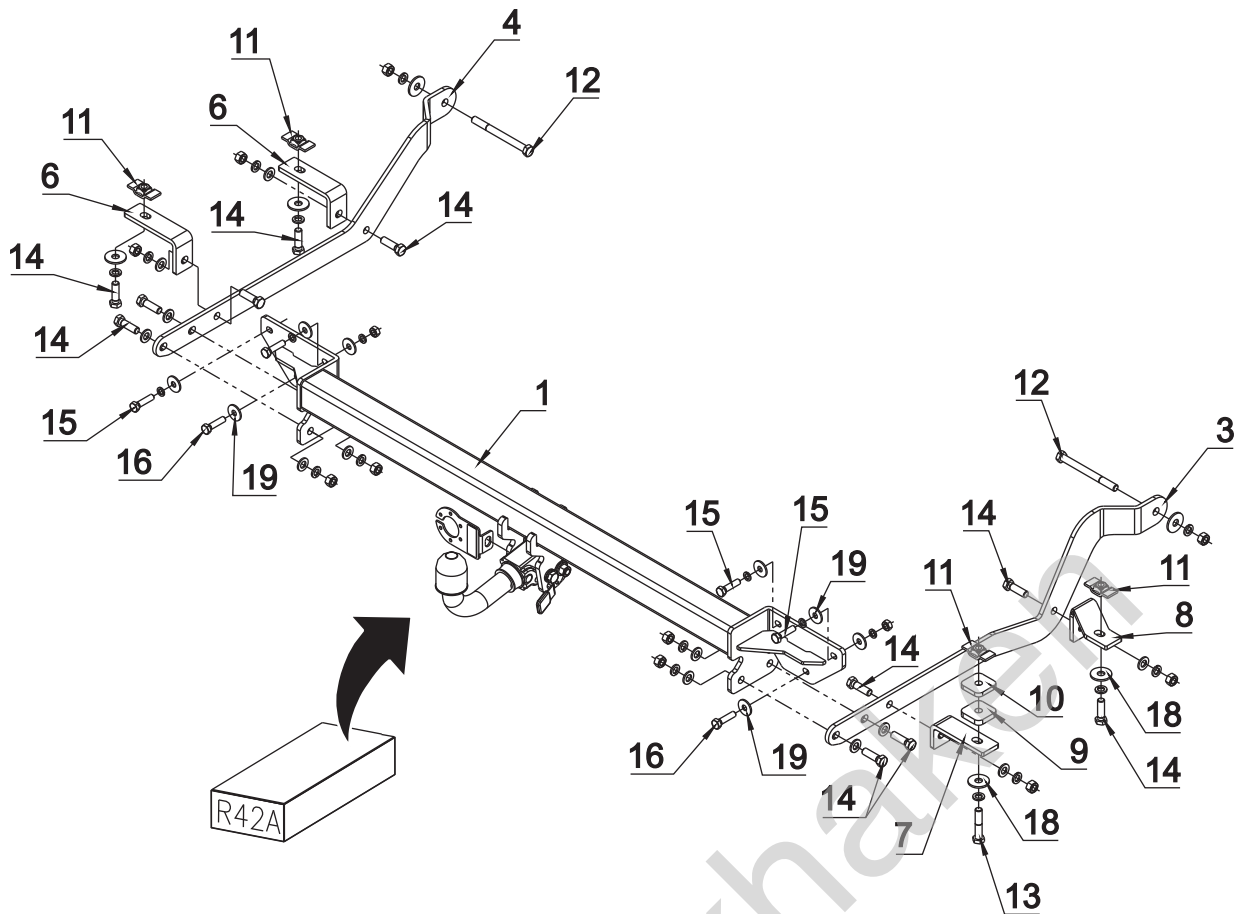

1		x1		M12x130	x2
2	 Art.nr-KL1R42A	x1		M12x60	x1
3		x1		M12x40	x11
4	 Art.nr-BL1R42A	x1		M10x1,25x40	x4
5		x1		M10x40	x2
6		x2		∅ 13	x12
7		x1		∅ 37x∅13x3 13 DIN 9021	6
8		x1		∅ 30x∅10.5x2.5 10 DIN 9021	8
9	 48x48x10mm	x1		∅ 12.2	x14
10	 48x48x8mm	x1		∅ 10.2	x6
11		x4		M12	x10
				M10	x2

