

AUTO-HAK Sp. z o.o.

ul. Słoneczna 16K 76-200 SŁUPSK
POLAND















tel/fax +48 59 8 414 414; +48 59 8 414 413

e-mail: office@autohak.com.pl

www.autohak.com.pl

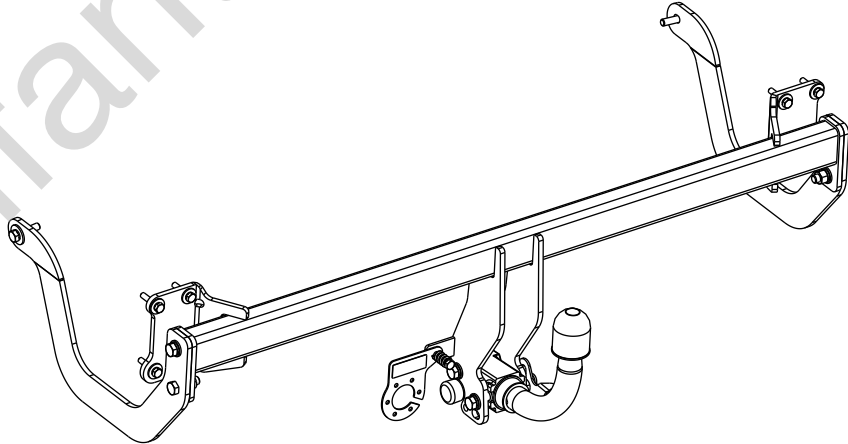

AUTO-HAK

	CITROEN C5 II Break/Tourer KOMBI, 1 rura wydechowa, GT 2,2HDI	Cat. no:
	 04.2008 →	P33A
	PEUGEOT 407 Break/SW KOMBI, 1 rura wydechowa, GT 2,2HDI	
	 10.2008 → 02.2011	  2h
e20	e20 * 94 / 20 * 1110 * 00	
D	10,4 kN	 <input checked="" type="checkbox"/>
	R=2010 kg	 <input type="checkbox"/>
	S=80 kg	 <input type="checkbox"/>
		
	M6 - 11 Nm	M8 - 25 Nm
	M10 - 50 Nm	M12 - 87 Nm
	M14 - 138 Nm	M16 - 210 Nm
	 0 km →  1000 km	

01

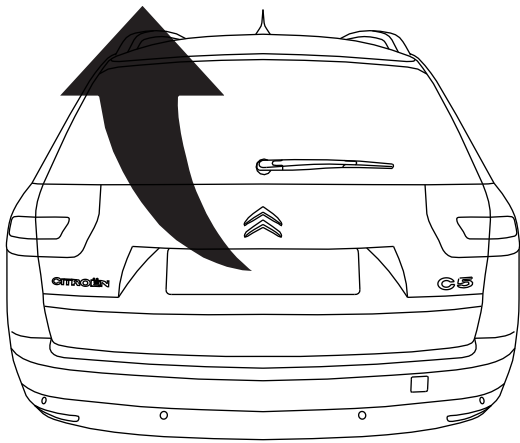

02

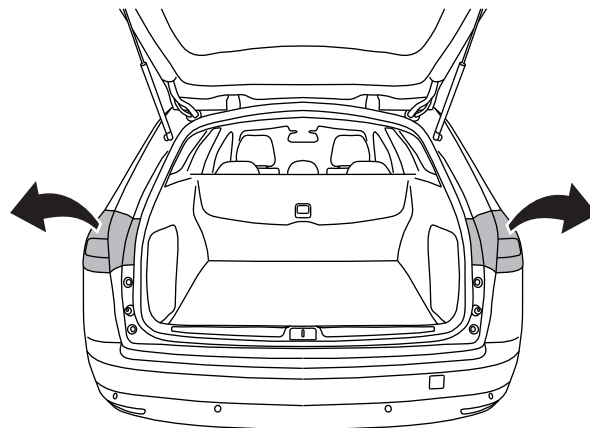

03

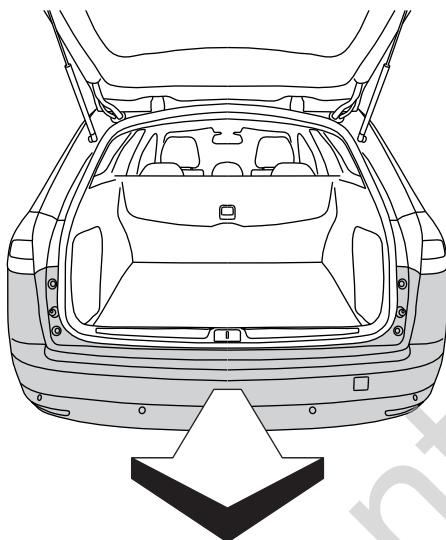

04

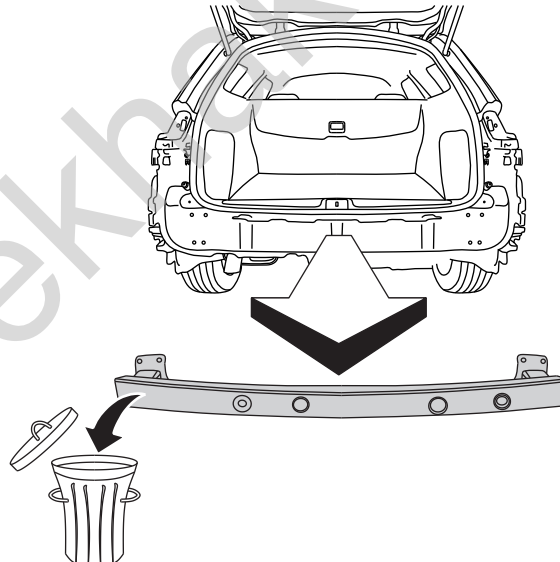

05

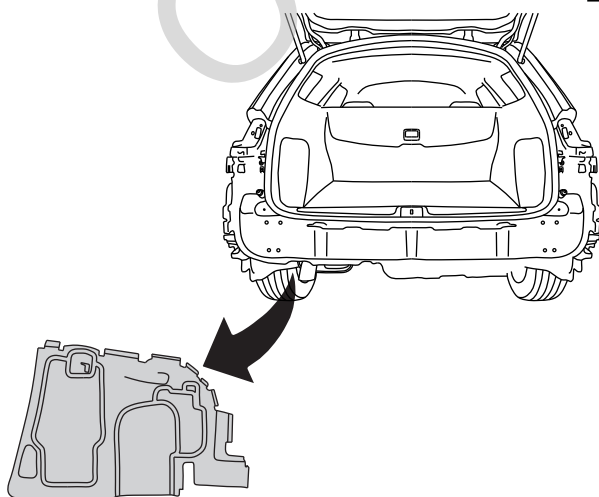

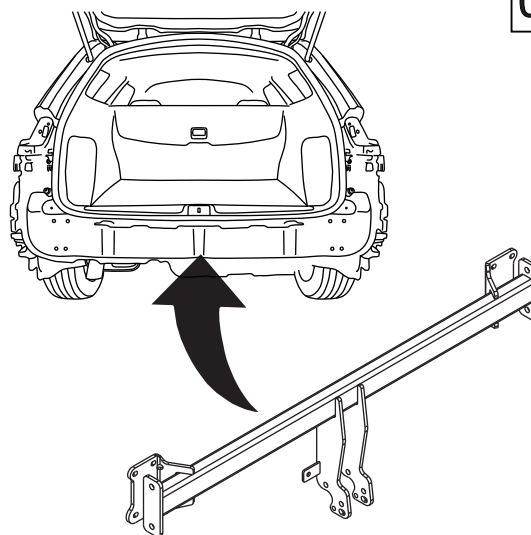

06

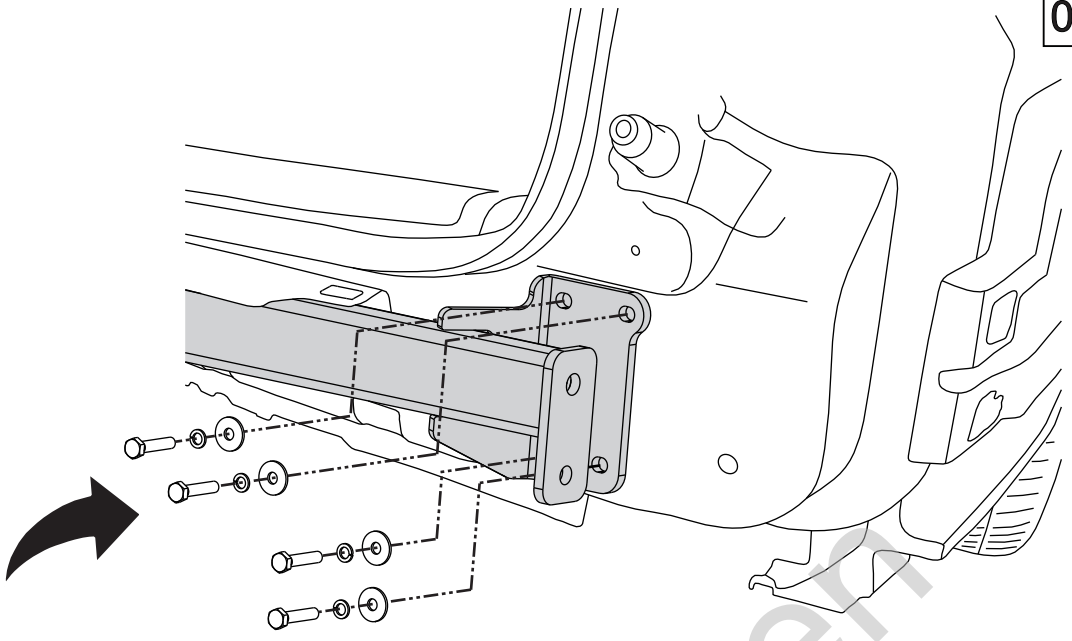
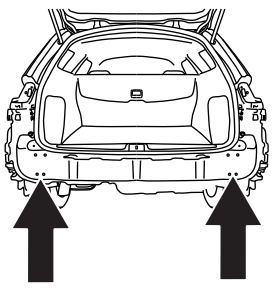

07



- 4x  M8x40mm
- 4x  $\varnothing 8,2\text{mm}$
- 4x  $\varnothing 24 \times \varnothing 8,4 \times 2\text{mm}$

08

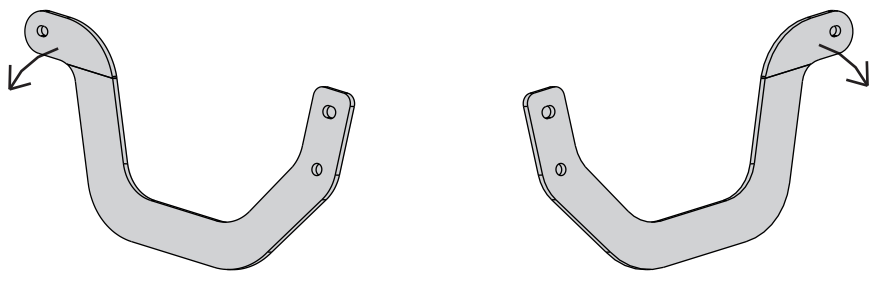
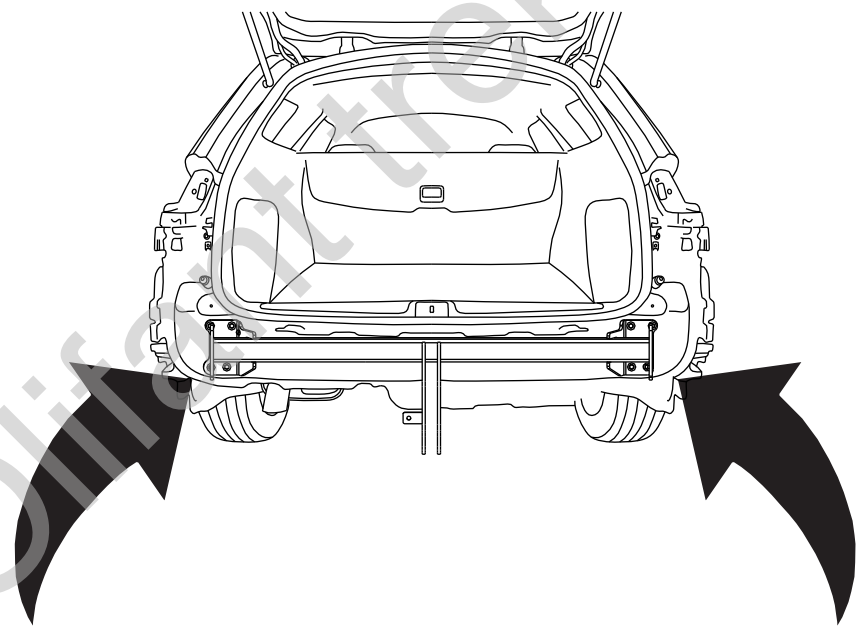

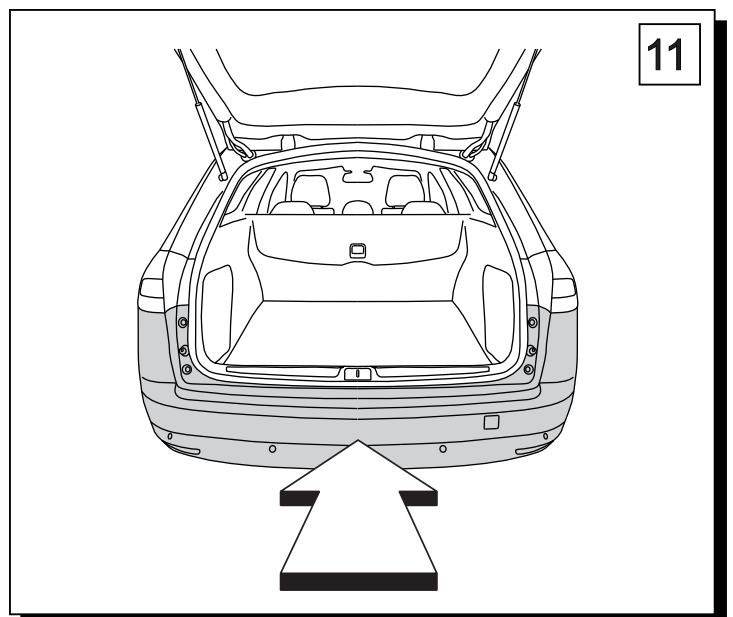
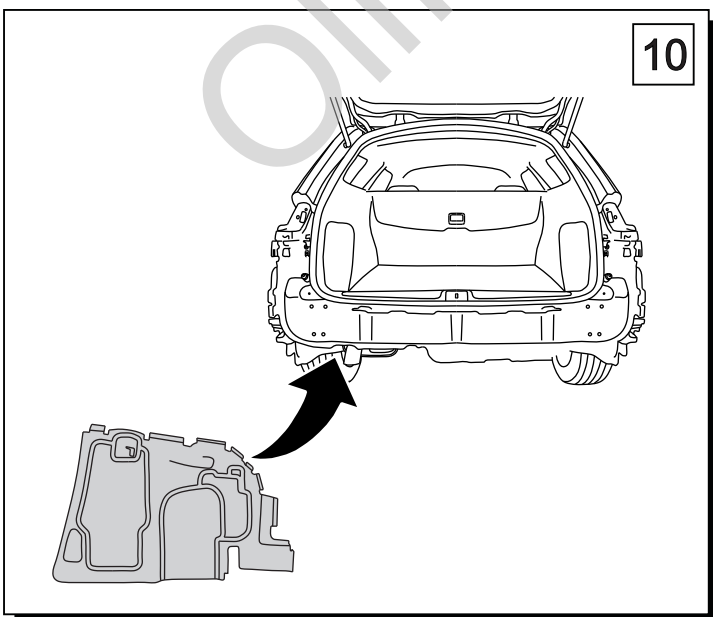
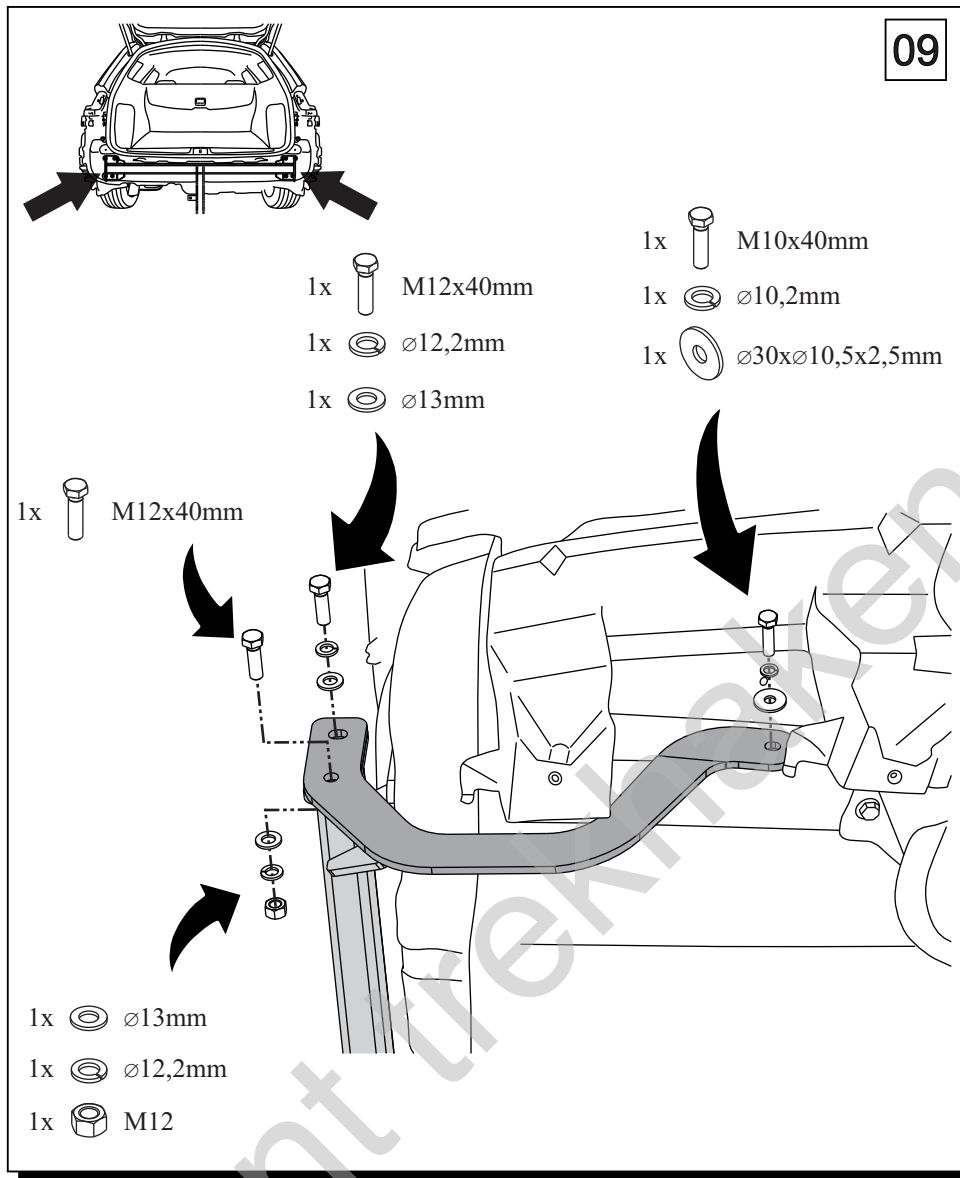

12

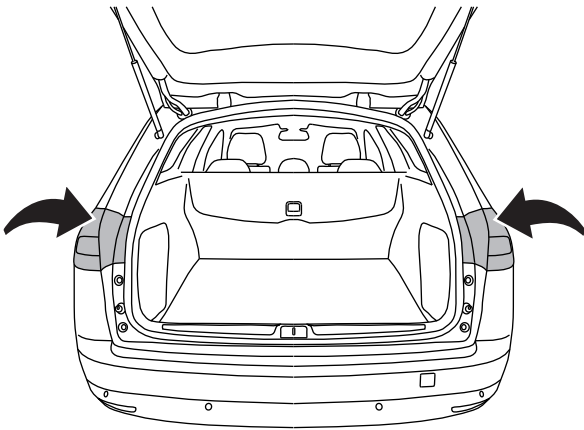

13

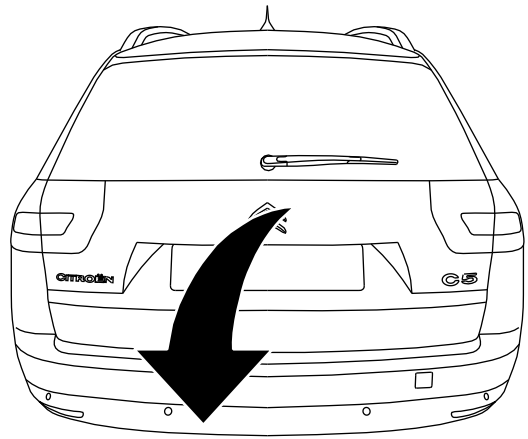

14

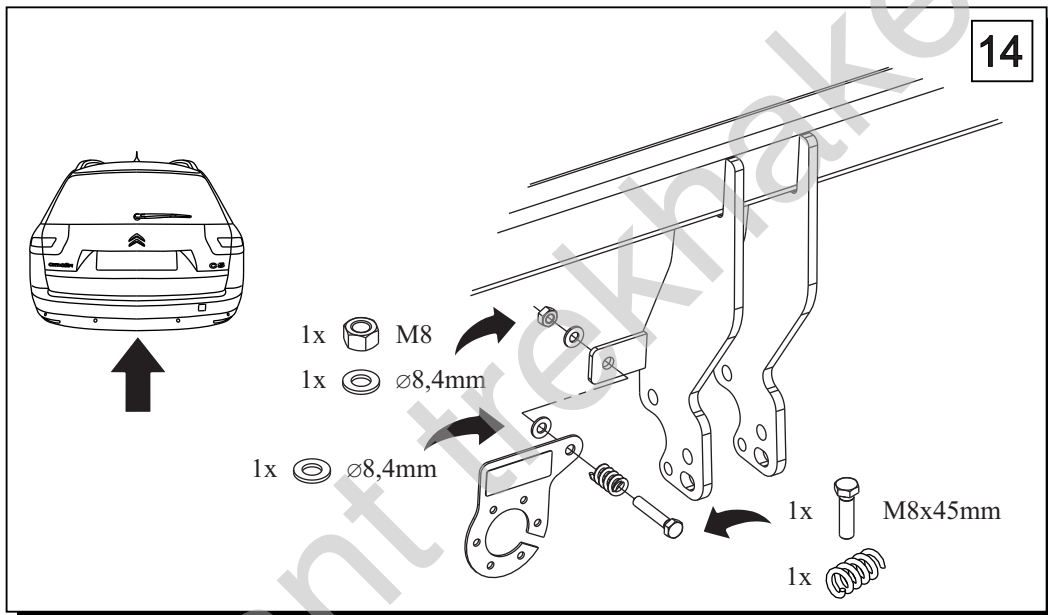

15

