

FITTING INSTRUCTION

Clamp mark in acc. with		Cables joining
ISO	PN	
1	L	Left directional lights
2	+	Rear fog lights
3	31	Ground
4	R	Right directional lights
5	58R	Right side parking lights
6	54	Stoplights
7	58L	Left side parking lights

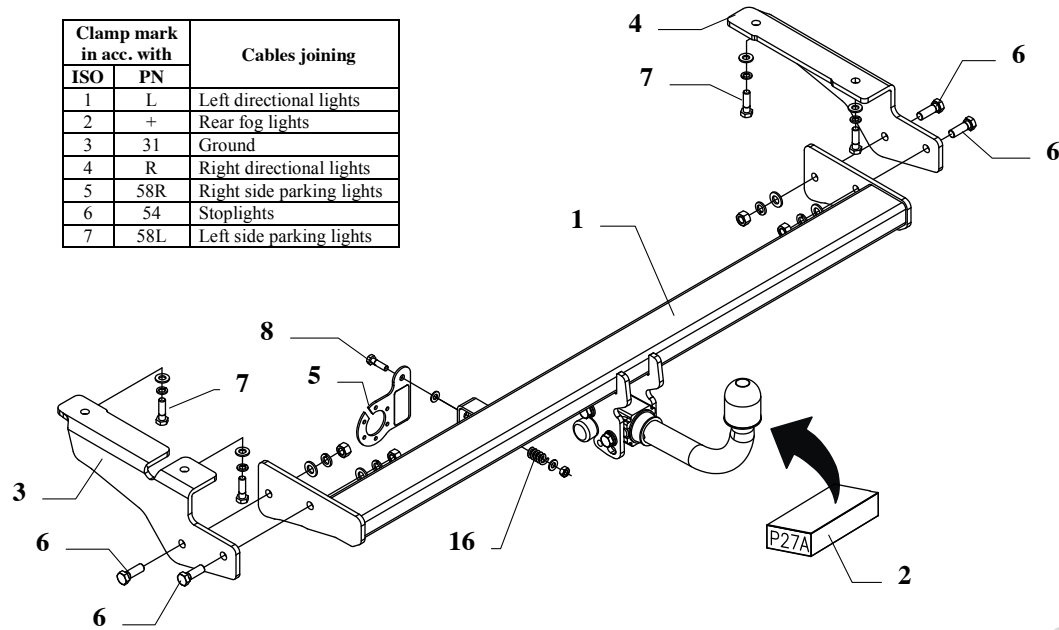

Fig. 1

This towbar is designed to assembly in following car:

CITROEN C5 I 4/5 doors, produced since 10.2004 till 03.2008, catalogue no. **P27A** and is prepared to tow trailers max total weight **1600 kg** and max vertical load **75 kg**.

From manufacturer

Thank you for buying our product. Their reliability has been confirmed in many tests. Reliability of towbar depends also on correct assembly and right operation. For this reasons we kindly ask to read carefully this instruction and apply to hints.

The towbar should be install in points described by a car producer.

Fitting instructions

1. Disassemble the bumper and plastic cover plate.
2. In factory prepared places fix side brackets (pos. 3 and 4) using bolts M10x35mm pos. 7 (loosely).

3. Assemble cover plate, before install cut out his fragments according to figure 2.
4. Put main bar of the towbar pos. 1 between fixed side brackets and twist on bolts M12x35mm (pos. 6).
5. Tighten all bolts according to the torque shown in the table.
6. Assemble the bumper, before assemble cut out his fragments according to figure 3.
7. Fix the socket plate (pos. 18) as shown on the drawing.
8. Fix body of the automat according to supplied instruction.
9. Fix the socket plate (pos. 5) as shown on the drawing.
10. Connect electric wires of 7-poles socket according to the instruction of the car. (Recommend to make at authorized service station)
11. Complete paint layer damaged during installation.

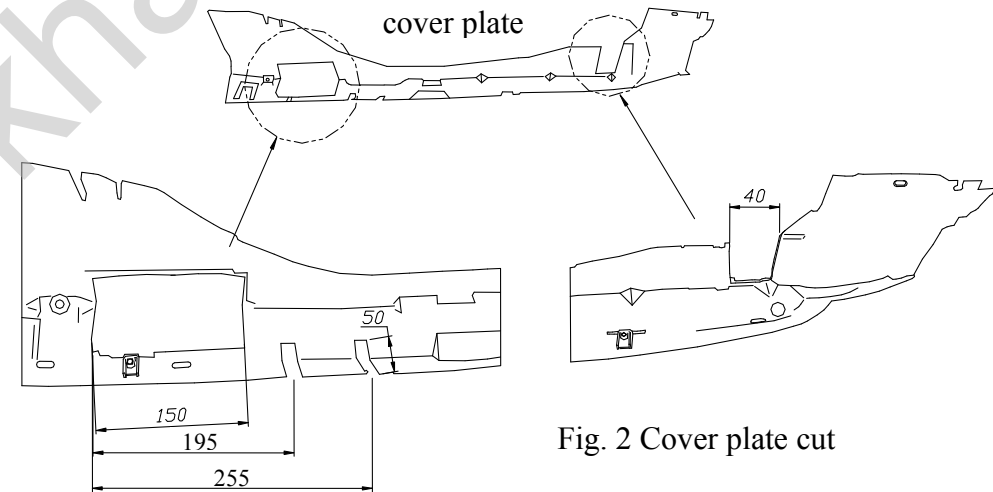

Fig. 2 Cover plate cut

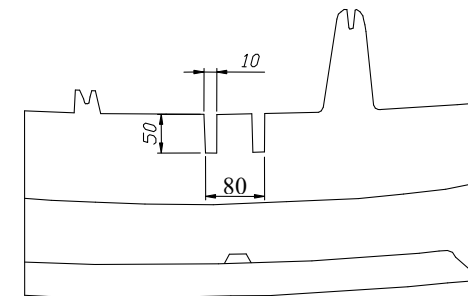

Fig. 3 Bumper cut.

Towbar accessories:

Pos. 1 Name: Main bar Quantity: 1	Pos. 5 Name: Socket plate Quantity: 1	Pos. 10 Name: Nut 8 B Quantity: 1 Dim.: M8	Pos. 15 Name: Spring washer Quantity: 4 Dim.: Ø 10,2 mm
Pos. 2 Name: Tow-ball Quantity: 1	Pos. 6 Name: Bolt 8,8 B Quantity: 4 Dim.: M12x35mm	Pos. 11 Name: Plain washer Quantity: 4 Dim.: Ø 13 mm	Pos. 16 Name: Spring Quantity: 1
Pos. 3 Name: Right bracket Quantity: 1	Pos. 7 Name: Bolt 8,8 B Quantity: 4 Dim.: M10x35mm	Pos. 12 Name: Plain washer Quantity: 4 Dim.: Ø 10,5 mm	
Pos. 4 Name: Left bracket Quantity: 1	Pos. 8 Name: Bolt 8,8 B Quantity: 1 Dim.: M8x30mm	Pos. 13 Name: Plain washer Quantity: 2 Dim.: Ø 8,3 mm	
	Pos. 9 Name: Nut 8 B Quantity: 4 Dim.: M12	Pos. 14 Name: Spring washer Quantity: 4 Dim.: Ø 12,2 mm	



PPUH AUTO-HAK Sp.J.

Produkcja Zaczepów Kulowych
Henryk i Zbigniew Nejman
76-200 SŁUPSK ul. Słoneczna 16K
tel/fax (059) 8-414-414; 8-414-413
E-mail: office@autohak.com.pl
www.autohak.com.pl

Towing hitch (without electrical set)

Class: **A50-X** Cat. no. **P27A**

Designed for:

Manufacturer: **CITROEN**

Model: **C5 I**

Type: **4/5 doors**

produced since 10.2004 till 03.2008

Technical data:

D-value: 9,17 kN

maximum trailer weight: **1600 kg**

maximum vertical cup load: **75 kg**

Approval number acc. to regulations EKG/ONZ 55.01: **E20 55R-01 1608**

Torque settings for nuts and bolts (8,8):

M6 - 11 Nm

M8 - 25 Nm

M10 - 50 Nm

M12 - 87 Nm

M14 - 138 Nm

M16 - 210 Nm

Foreword

This towing hitch is designed according to rules of safety traffic regulations. The towing hitch is a safety component and can be install only by qualified personnel. Any alteration or conversion of the towing hitch is prohibited and would lead to cancellation of design certification. Remove insulating compound and underseal from vehicle (if present) in the areas of the matting surfaces of the towing hitch. The vehicle manufacturer's specifications regarding trailer load and max. vertical cup mass are decisive for driving whereat values for the towing hitch cannot be exceeded.

D-value formula:

$$\frac{\text{Max trailer weight [kg]} \times \text{Max vehicle weight [kg]}}{\text{Max trailer weight [kg]} + \text{Max vehicle weight [kg]}} \times \frac{9,81}{1000} = D \text{ [kN]}$$