

FITTING INSTRUCTION

| Clamp mark in acc. with | | Cables joining |
|-------------------------|-----|---------------------------|
| ISO | PN | |
| 1 | L | Left directional lights |
| 2 | + | Rear fog lights |
| 3 | 31 | Ground |
| 4 | R | Right directional lights |
| 5 | 58R | Right side parking lights |
| 6 | 54 | Stoplights |
| 7 | 58L | Left side parking lights |

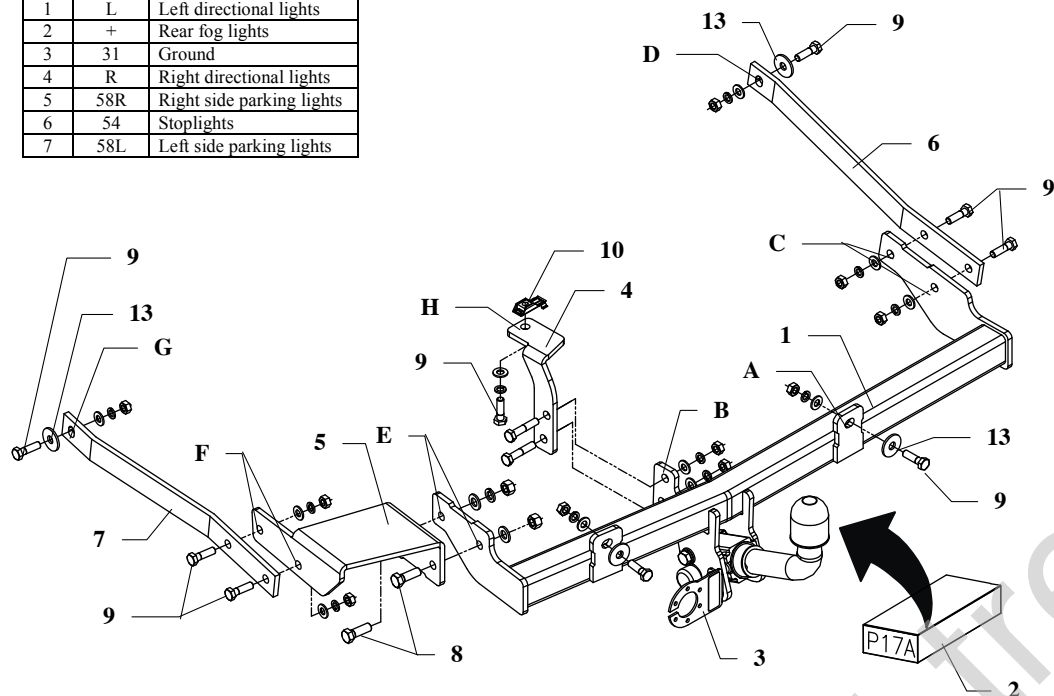

This towbar is designed to assembly in following cars:
CITROEN XANTIA Break, ESTATE (X1/X2) produced since 06.1995 till 03.2001, catalogue no. **P17A** and is prepared to tow trailers max total weight **1500 kg** and max vertical load **85 kg**.

From manufacturer

Thank you for buying our product. Their reliability has been confirmed in many tests. Reliability of towbar depends also on correct assembly and right operation. For this reasons we kindly ask to read carefully this instruction and apply to hints.

The towbar should be install in points described by a car producer.

Fitting instructions

1. Disassemble the rear bumper and take out spare wheel.
2. Put main bar of the towbar (pos. 1) to rear part of the car (from inside) and through holes pos. A fix it by bolts M10x35mm (pos. 9) and big washer (pos. 13) as show on the drawing. Fix loosely.
3. Through holes pos. C fix right arm (pos. 6) using bolts M10x35mm (pos. 9) next through hole pos. D of element pos. 6 fix to the original holes in the car using bolts M10x35mm (pos. 9) and big washer (poz. 13), as shown on the drawing.
4. Through holes pos. E fix joint element (pos. 5) by bolts M12x35mm (pos. 8), loosely.
5. Through holes pos. F fix elements 5 and 7 as show on the drawing using bolts M10x35mm (pos. 9) and next through hole pos. G of element 7 fix with original holes in the car using bolts M10x35mm (pos. 9) and big washer (pos. 13).
6. Fix central bracket pos. 4 through holes pos. B with main bar using bolts M10x35mm (pos. 9). Through hole pos. H fix to caget nut pos. 10 by bolt M10x35mm (caget nut put into the central chassis member in advance) .
7. Tighten all bolts according to the torque shown in the table.
8. Fix body of the automat and place tow-ball according to supplied instruction. Note! Remember to place socket plate (pos. 3) as shown on the drawing 1.
9. Connect electric wires of 7-poles socket according to the instruction of the car. (Recommend to make at authorized service station)
10. Complete paint layer damaged during installation.

Torque settings for nuts and bolts (8,8):

| | | | |
|------------|-------|------------|--------|
| M8 | 25 Nm | M10 | 55 Nm |
| M12 | 85 Nm | M14 | 135 Nm |











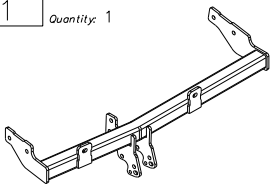
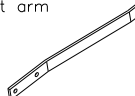

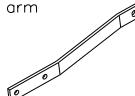
NOTE

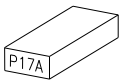
After install the towbar you should get adequate note in registration book (at authorised service station).The car should be equipped with:

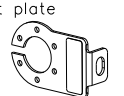
- Indicators
- Tow mirrors

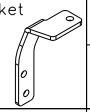
After 1000km check all bolts and nuts. The ball of towbar must be always kept clear and conserve with a grease.

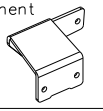
Towbar accessories:

| | | | | | |
|-----------------------------------------------------------------------------------|--------------------------------------|-----------------------------------------------------------------------------------|----------------------------------------------------|-----------------------------------------------------------------------------------|--------------------------------------------------------|
| Pos. 1 | Name: Main bar Quantity: 1 | Pos. 6 | Name: Right arm Quantity: 1 | Pos. 12 | Name: Nut 8 B Quantity: 10 Dim.: M10 |
|  | |  | |  | |
| | | Pos. 7 | Name: Left arm Quantity: 1 | Pos. 13 | Name: Washer Quantity: 4 Dim.: Ø35xØ12x3mm |
| | |  | |  | |
| Pos. 2 | Name: Tow-ball Quantity: 1 | Pos. 8 | Name: Bolt 8,8 B Quantity: 2 Dim.: M12x35mm | Pos. 14 | Name: Plain washer Quantity: 6 Dim.: Ø 13 mm |
|  | |  | |  | |
| Pos. 3 | Name: Socket plate Quantity: 1 | Pos. 9 | Name: Bolt 8,8 B Quantity: 11 Dim.: M10x35mm | Pos. 15 | Name: Plain washer Quantity: 11 Dim.: Ø 10,5 mm |
|  | |  | |  | |
| Pos. 4 | Name: Central bracket Quantity: 1 | Pos. 10 | Name: Capet nut Quantity: 1 Dim.: M10 | Pos. 16 | Name: Spring washer Quantity: 6 Dim.: Ø 12,2 mm |
|  | |  | |  | |
| Pos. 5 | Name: Join element Quantity: 1 | Pos. 11 | Name: Nut 8 B Quantity: 2 Dim.: M12 | Pos. 17 | Name: Spring washer Quantity: 11 Dim.: Ø 10,2 mm |
|  | |  | |  | |



PPUH AUTO-HAK S.J.

Produkcja Haków Holowniczych
Henryk i Zbigniew Nejman
76-200 SŁUPSK ul. Słoneczna 16K
tel/fax (059) 8-414-414; 8-414-413
e-mail: office@autohak.com.pl
www.autohak.com.pl

Towing hitch (without electrical set)

Class: **A50-X** Cat. no. **P17A**

Designed for:

Manufacturer: **CITROEN**

Model: **XANTIA Break**

Type: **ESTATE (X1/X2)**

produced since 06.1995 till 03.2001

Technical data:

D-value: 8,35 kN

maximum trailer weight: **1500 kg**

maximum vertical cup load: **85 kg**

Approval number acc. to regulations EKG/ONZ 55.01: E20-55R-01 1800

Foreword

This towbar is designed according to rules of safety traffic regulations. The towing hitch is a safety component and can be install only by qualified personnel. Any alteration or conversion of the towing hitch is prohibited and would lead to cancellation of design certification. Remove insulating compound and underseal from vehicle (if present) in the area of the matting surfaces of the towing hitch.

The vehicle manufacturer's specifications regarding trailer load and max. vertical cup load are decisive for driving, and values for the towing hitch cannot be exceeded.

D-value formula:

$$\frac{\text{Max trailer weight [kg]} \times \text{Max vehicle weight [kg]}}{\text{Max trailer weight [kg]} + \text{Max vehicle weight [kg]}} \times \frac{9,81}{1000} = D \text{ [kN]}$$