

FITTING INSTRUCTION

Clamp mark in acc. with		Cables joining
ISO	PN	
1	L	Left directional lights
2	+	Rear fog lights
3	31	Ground
4	R	Right directional lights
5	58R	Right side parking lights
6	54	Stoptlights
7	58L	Left side parking lights

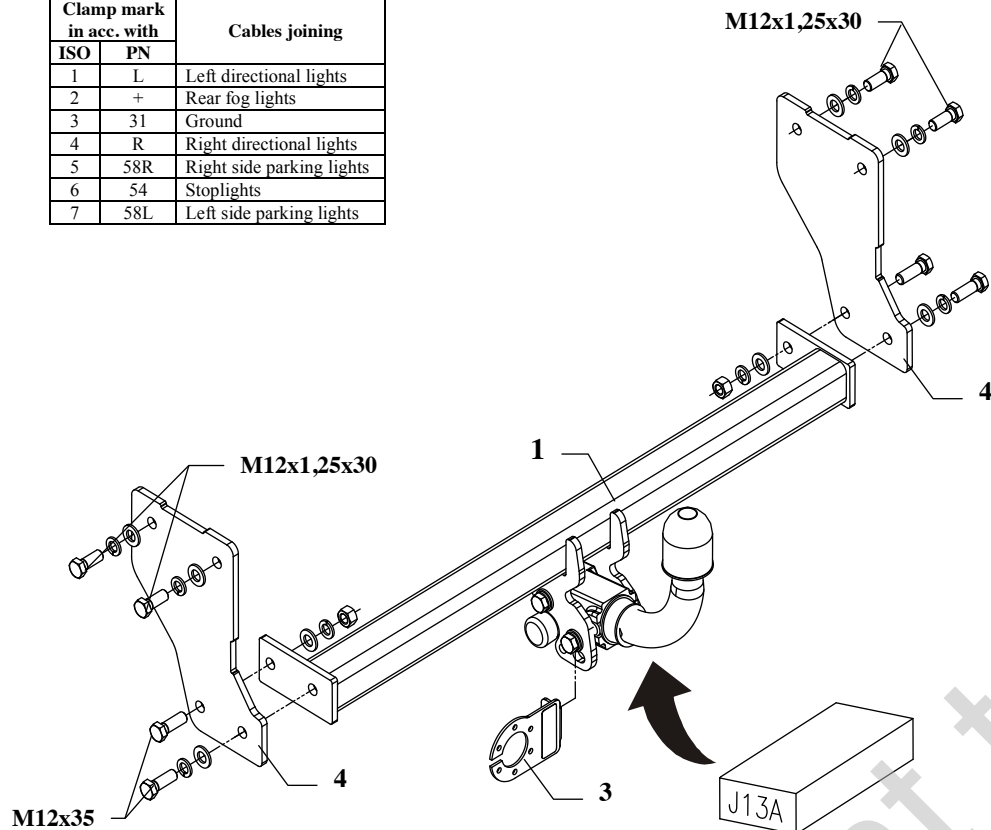

This towbar is designed to assembly in following cars: **HYUNDAI ATOS, 5 DOORS**, produced since 03.1998, catalogue no. **J13A** and is prepared to tow trailers max total weight **700 kg** and max vertical load **50 kg**.

From manufacturer

Thank you for buying our product. Their reliability has been confirmed in many tests. Reliability of towbar depends also on correct assembly and right operation. For this reasons we kindly ask to read carefully this instruction and apply to hints.

The towbar should be install in points described by a car producer. You can install it without bumper cut out and disassemble.

The instruction of the assembly

1. Put side brackets (pos. 4) to chassis members and fix it using bolts M12x1,25x30mm (pos. 6) – loosely.
2. Between brackets put the main bar of the towbar (pos. 1) and fix with bolts M12x35mm (pos. 5), as shown on the drwaing.
3. Fix body of the automat and place tow-ball according to supplied instruction. Note! Remember to place socket plate (pos. 3) as shown on the drawing 1.
4. Tighten all bolts according to the torque shown in the table.
5. Connect electric wires of 7-poles socket according to the instruction of the car. (Recommend to make at authorized service station).
6. Complete paint layer damaged during installation.

Torque settings for nuts and bolts (8,8):	
M 8 - 25 Nm	M 10 - 55 Nm
M 12 - 85 Nm	M 14 - 135 Nm







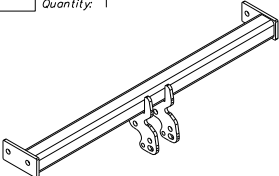

NOTE

After install the towbar you should get adequate note in registration book (at authorised service station).The car should be equipped with:

- Indicators
- Tow mirrors

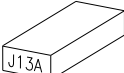
After 1000km of exploitation check all bolts and nuts. The ball of towbar must be always kept clear and conserve with a grease.

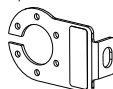
Towbar accessories:

Pos. 1	Name: Main bar Quantity: 1	Pos. 4	Name: Side bracket Quantity: 2	Pos. 8	Name: Plain washer Quantity: 8 Dim.: \varnothing 13 mm
					
		Pos. 5	Name: Bolt 8,8 B Quantity: 4 Dim.: M12x35mm	Pos. 9	Name: Spring washer Quantity: 8 Dim.: \varnothing 12,2 mm
					
Pos. 2	Name: Tow ball Quantity: 1	Pos. 6	Name: Bolt 8,8 B Quantity: 4 Dim.: M12x1,25x30mm		
					
Pos. 3	Name: Socket plate Quantity: 1	Pos. 7	Name: Nut 8 B Quantity: 2 Dim.: M12		
					



PPUH AUTO-HAK S.J.

Produkcja Zaczepów Kulowych
Henryk i Zbigniew Nejman
76-200 SŁUPSK ul. Słoneczna 16K
tel/fax (059) 8-414-414; 8-414-413
email: office@autohak.com.pl
www.autohak.com.pl

Towing hitch (without electrical set)

Class: **A50-X** Cat. no. **J13A**

Designed for:

Manufacturer: **HYUNDAI**

Model: **ATOS**

Type: **5 door**

produced since 03.1998

Technical data:

D-value: 4,4 kN

maximum trailer weight: **700 kg**

maximum vertical cup load: **50 kg**

Approval number according to Directive 94/20/EC: **e20*94/20*0569*00**

Foreword

This towbar is designed according to rules of safety traffic regulations. The towing hitch is a safety component and can be install only by qualified personnel. Any alteration or conversion of the towing hitch is prohibited and would lead to cancellation of design certification. Remove insulating compound and underseal from vehicle (if present) in the area of the matting surfaces of the towing hitch. The vehicle manufacturer's specifications regarding trailer load and max. vertical cup load are decisive for driving whereat values for the towing hitch cannot be exceeded.

D-value formula:

$$\frac{\text{Max trailer weight [kg]} \times \text{Max vehicle weight [kg]}}{\text{Max trailer weight [kg]} + \text{Max vehicle weight [kg]}} \times \frac{9,81}{1000} = D \text{ [kN]}$$