

FITTING INSTRUCTION

Clamp mark in acc. with		Cables joining
ISO	PN	
1	L	Left directional lights
2	+	Rear fog lights
3	31	Ground
4	R	Right directional lights
5	58R	Right side parking lights
6	54	Stoplights
7	58L	Left side parking lights

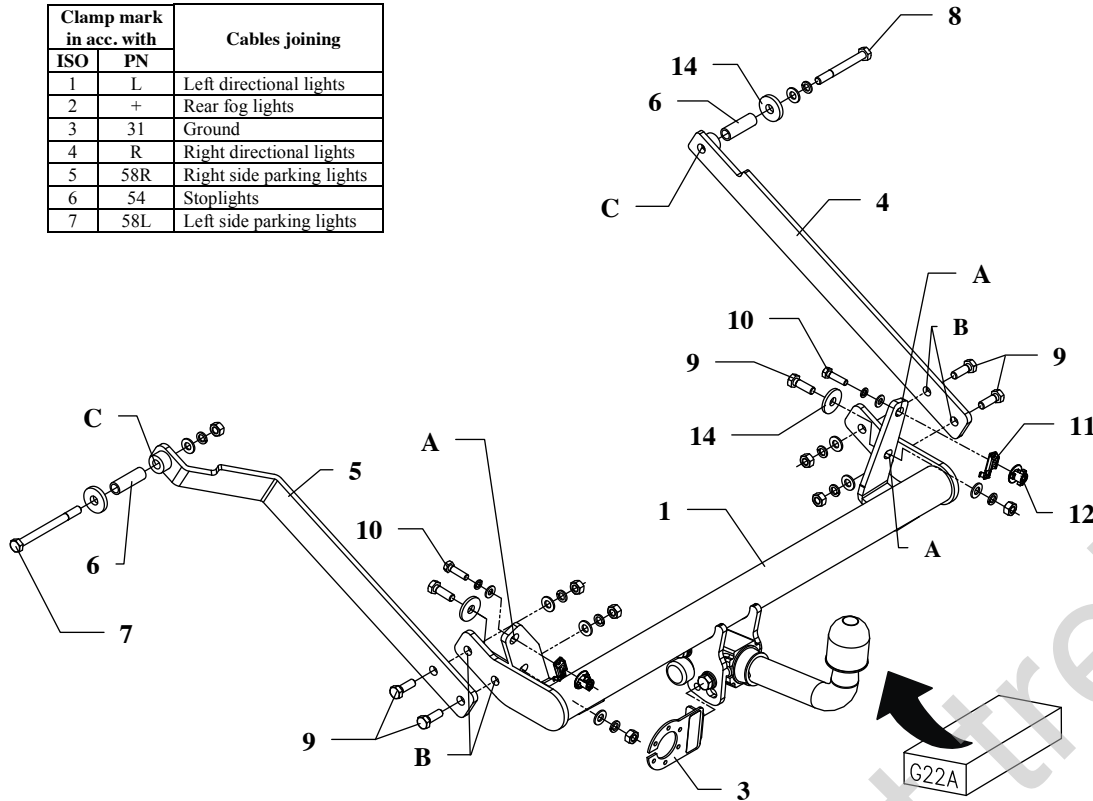

This towing hitch is designed to assembly in following car:
RENAULT MEGANE I CLASSIC, 4 doors, produced since 09.1996 till 08.2003, catalogue no. **G22A** and is prepared to tow trailers max total weight **1300 kg** and max vertical load **75 kg**.

From manufacturer

Thank you for buying our product. Their reliability has been confirmed in many tests. Reliability of towing hitch depends also on correct assembly and right operation. For this reasons we kindly ask to read carefully this instruction and apply to hints.

The towing hitch should be install in points described by a car producer.

The instruction of the assembly

1. From below a car, in rear side find plugged holes (left and right side) – upper holes of towbar. Next remove plugs and put „nut with basket M8” pos. 12 - only for model Renault Megane Classic produced since 1996 till 1998, or „Caged Nut M8” pos. 11 - only for model Renault Megane Classic produced since 1999 till 2002.
2. The main bar of the towing hitch (pos. 1) put below the car and through holes (pos. A) fix using bolts M8x30mm (pos. 10) and M10x30mm (pos. 9), use big washers (pos. 14) too.
3. From outside, in original holes in chassis members put distance sleeves (pos. 6) from accessories.
4. To already installed main bar (pos. 1) through holes (pos. B) fix side brackets (pos. 4 and 5) using bolts M10x30mm (pos. 9).
5. Through previously installed distance sleeves in chassis members and towing hitch holes (pos. C) fix all using bolts M10x120mm (pos. 7) and M10x90mm (pos. 8) from accessories.
6. Fix body of the automat and place tow-ball according to supplied instruction. Note! Remember to place socket plate (pos. 3) as shown on the drawing 1.
7. Fix tight all bolts according to the torque shown in the table.
8. Connect electric wires of 7-poles socket according to the instruction of the car. (Recommend to make at authorized service station).
9. Complete the paint coating damaged during installation.

Torque settings for nuts and bolts (8,8):

M6 - 11 Nm	M8 - 25 Nm	M10 - 50 Nm
M12 - 87 Nm	M14 - 138 Nm	M16 - 210 Nm











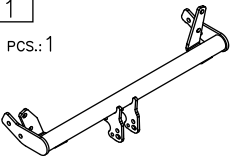
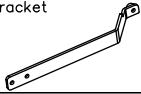

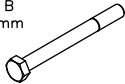

NOTE

After installation of a towing hitch you should get adequate note in registration book (at authorised service station). The car should be equipped with:

- Indicators
- Tow mirrors

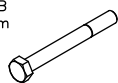
After 1000km of exploitation check all bolts and nuts. The ball of towing hitch must be always kept clear and conserve with a grease.

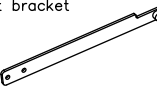
Towing hitch accessories:

Pos. 1 Main bar PCS.: 1	Pos. 5 Left bracket PCS.: 1	Pos. 10 Bolt 8,8 B M8x30mm PCS.: 2	Pos. 15 Plain washer ø10,5mm PCS.: 8
			
	Pos. 6 Distance sleeve ø17x2,35mm L=53mm PCS.: 2	Pos. 11 Caget nut M8 PCS.: 2	Pos. 16 Plain washer ø8,4mm PCS.: 2
			
Pos. 2 Tow ball PCS.: 1	Pos. 7 Bolt 8,8 B M10x120mm PCS.: 1	Pos. 12 Nut with basket M8 PCS.: 2	Pos. 17 Spring washer ø10,2mm PCS.: 8
			
Pos. 3 Socket plate PCS.: 1	Pos. 8 Bolt 8,8 B M10x90mm PCS.: 1	Pos. 13 Nut 8 B M10 PCS.: 7	Pos. 18 Spring washer ø8,2mm PCS.: 2
			
Pos. 4 Right bracket PCS.: 1	Pos. 9 Bolt 8,8 B M10x30mm PCS.: 6	Pos. 14 Plain washer ø30xø10,5x2,5mm PCS.: 4	
			



PPUH AUTO-HAK Sp.J.

Produkcja Zaczepów Kulowych
Henryk i Zbigniew Nejman
76-200 SŁUPSK ul. Słoneczna 16K
tel/fax (059) 8-414-414; 8-414-413
E-mail: office@autohak.com.pl
www.autohak.com.pl

Towing hitch (without electrical set)

Class: **A50-X** Cat. no. **G22A**

Designed for:

Manufacturer: **RENAULT**

Model: **MEGANE I CLASSIC**

Type: **4 doors**

produced since 09.1996 till 08.2003

Technical data:

D-value: 7,3 kN

maximum trailer weight: **1300 kg**

maximum vertical cup load: **75 kg**

Approval number according to Directive 94/20/EC: **e20*94/20*1000*00**

Foreword

This towing hitch is designed according to rules of safety traffic regulations. The towing hitch is a safety component and can be install only by qualified personnel. Any alteration or conversion of the towing hitch is prohibited and would lead to cancellation of design certification. Remove insulating compound and underseal from vehicle (if present) in the area of the matting surfaces of the towing hitch.

The vehicle manufacturer's specifications regarding trailer mass and max. vertical cup mass are decisive for driving whereat values for the towing hitch cannot be exceeded.

D-value formula:

$$\frac{\text{Max trailer weight [kg]} \times \text{Max vehicle weight [kg]}}{\text{Max trailer weight [kg]} + \text{Max vehicle weight [kg]}} \times \frac{9,81}{1000} = D \text{ [kN]}$$