

FITTING INSTRUCTION

Clamp mark in acc. with		Cables joining
ISO	PN	
1	L	Left directional lights
2	+	Rear fog lights
3	31	Ground
4	R	Right directional lights
5	58R	Right side parking lights
6	54	Stoptlights
7	58L	Left side parking lights

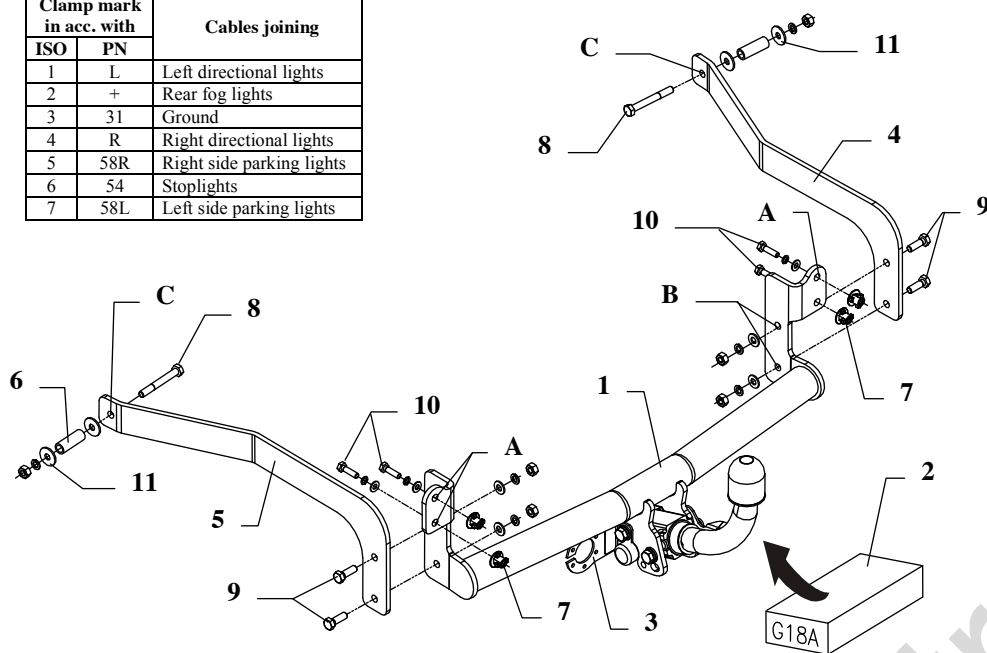

This towbar is designed to assembly in following car:
RENAULT LAGUNA I, 5 doors, produced since 11.1993 till 03.2001,
 catalogue no. **G18A** and is prepared to tow trailers max total weight
1650 kg and max vertical load **75 kg**.

From manufacturer

Thank you for buying our product. Their reliability has been confirmed in many tests. Reliability of towbar depends also on correct assembly and right operation. For this reasons we kindly ask to read carefully this instruction and apply to hints.

The towbar should be install in points described by a car producer.

The instruction of the assembly

1. Disassemble rear muffler.
2. From below the car find infatuated holes on the left and right side (two per side), break open it and insert nuts with basket M8 (pos. 7).
3. Put the main bar of the towbar (pos. 1) below the car and through holes (pos. A) fix using bolts M8x30mm (pos. 10) from towbar accessories.
4. To chassis members slip distance sleeves – pos. 6 (by piece on each side).
5. To mounted main bar of the towbar (pos. 1), through holes (pos. B) twist brackets (pos. 4 and 5) using bolts M10x30mm (pos. 9).
6. Through holes (pos. C) and distance sleeves in chassis members twist all by bolts M10x80mm (pos. 8) from accessories.
7. Fix body of the automat and place tow-ball according to supplied instruction. Note! Remember to place socket plate (pos. 3) as shown on the drawing 1.
8. Reassemble thermal shield and rear muffler.
9. Tighten all bolts according to the torque shown in the table.
10. Connect electric wires of 7-poles socket according to the instruction of the car. (Recommend to make at authorized service station).
11. Complete paint layer damaged during installation.

Torque settings for nuts and bolts (8,8):

M6 - 11 Nm	M8 - 25 Nm	M10 - 50 Nm
M12 - 87 Nm	M14 - 138 Nm	M16 - 210 Nm

NOTE

After install the towbar you should get adequate note in registration book (at authorised service station).The car should be equipped with:

- Indicators
- Tow mirrors

After 1000km of exploitation check all bolts and nuts. The ball of towbar must be always kept clear and conserve with a grease.

Towbar accessories:

Pos. 1 Main bar PCS.: 1	Pos. 6 Distance sleeve ø17x2mm L=48mm PCS: 2	Pos. 12 Plain washer ø10,5mm PCS.: 4
Pos. 2 Tow ball PCS.: 1	Pos. 7 Nut with basket M8 PCS: 4	Pos. 13 Plain washer ø8,5mm PCS.: 4
Pos. 3 Socket plate PCS.: 1	Pos. 8 Bolt 8,8 B M10x80mm PCS.: 2	Pos. 14 Spring washer ø10,2mm PCS.: 6
Pos. 4 Right bracket PCS.: 1	Pos. 9 Bolt 8,8 B M10x30mm PCS.: 4	Pos. 15 Spring washer ø8,2mm PCS.: 4
Pos. 5 Left bracket PCS.: 1	Pos. 10 Bolt 8,8 B M8x30mm PCS.: 4	Pos. 16 Nut 8 B M10 PCS.: 6
	Pos. 11 Plain washer ø30xø10,5x2,5mm PCS.: 4	Pos. 17 Ball cover PCS.: 1



PPUH AUTO-HAK Sp.J.

Produkcja Zaczepów Kulowych
Henryk i Zbigniew Nejman
76-200 SŁUPSK ul. Słoneczna 16K
tel/fax (0-59) 8-414-414; 8-414-413
e-mail: office@autohak.com.pl
www.autohak.com.pl

Towing hitch (without electrical set)

Class: **A50-X** Cat. no. **G18A**

Designed for:

Manufacturer: **RENAULT**

Model: **LAGUNA I**

Type: **5 doors**

produced since 11.1993 till 03.2001

Technical data:

D-value: 8,84 kN

maximum trailer weight: **1650 kg**

maximum vertical cup load: **75 kg**

Approval number according to Directive 94/20/EC: e20*94/20*0962*00

Foreword

This towbar is designed according to rules of safety traffic regulations. The towing hitch is a safety component and can be install only by qualified personnel. Any alteration or conversion of the towing hitch is prohibited and would lead to cancellation of design certification. Remove insulating compound and underseal from vehicle (if present) in the area of the matting surfaces of the towing hitch.

The vehicle manufacturer's specifications regarding trailer load and max. vertical cup load are decisive for driving, and values for the towing hitch cannot be exceeded.

D-value formula:

$$\frac{\text{Max trailer weight [kg]} \times \text{Max vehicle weight [kg]}}{\text{Max trailer weight [kg]} + \text{Max vehicle weight [kg]}} \times \frac{9,81}{1000} = D \text{ [kN]}$$