

AUTO-HAK Sp. z o.o.

ul. Słoneczna 16K 76-200 SŁUPSK
POLAND

tel/fax +48 59 8 414 414; +48 59 8 414 413

e-mail: office@autohak.com.pl

www.autohak.com.pl



AUTO-HAK

PEUGEOT 3008 II

AdBlue, ~~Hybrid~~

 05.2016 →

CITROEN C5 Aircross

AdBlue, Mild Hybrid, ~~Plug-In Hybrid~~

 01.2019 →

Nr kat.

F47A

 E20-55R-01 5057

 10,10 kN

 R=2000 kg

 S=100 kg



2h

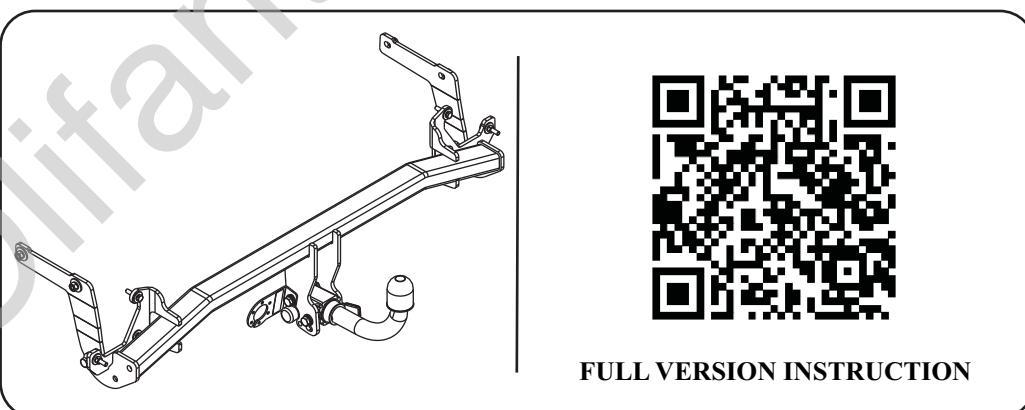
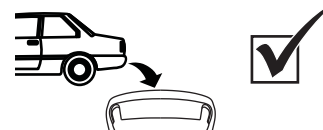









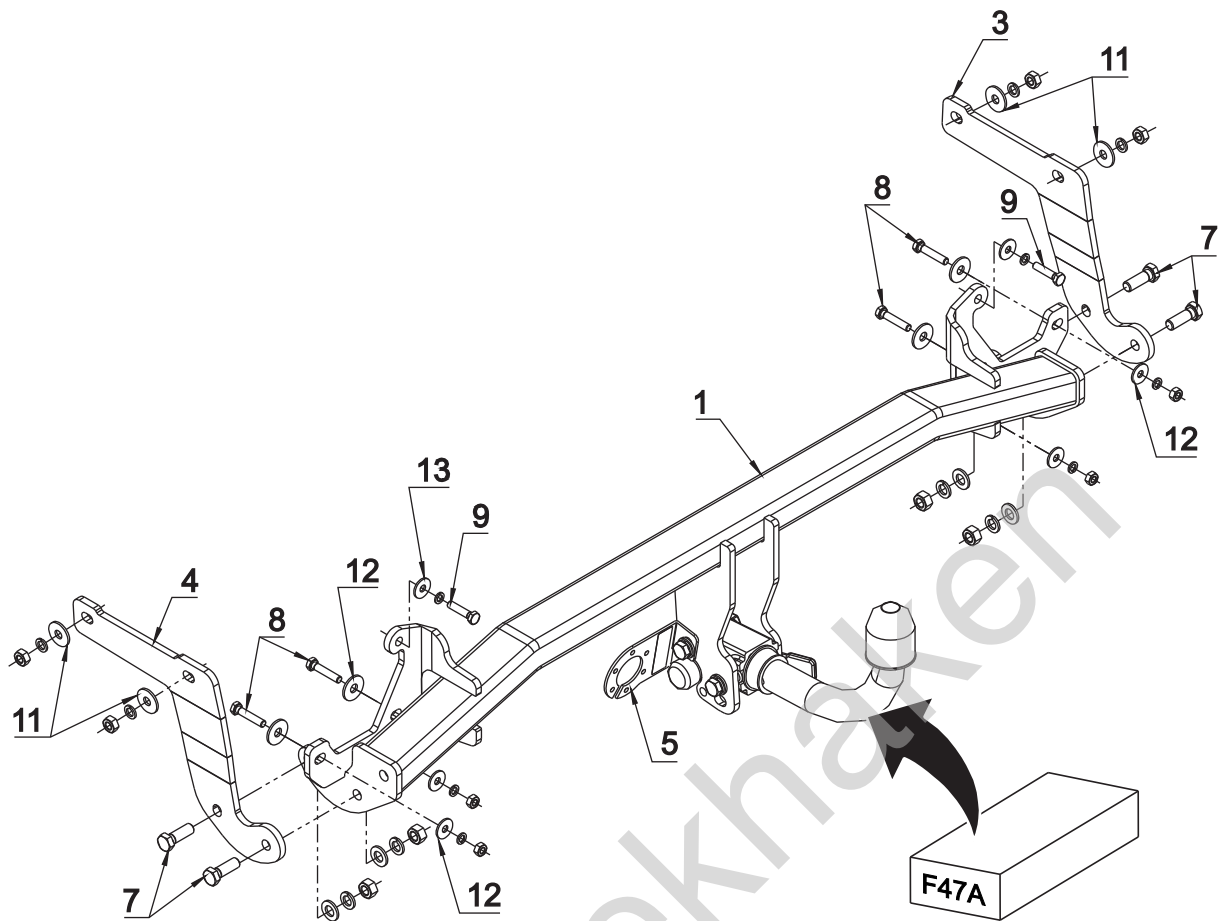

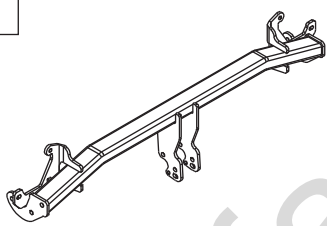

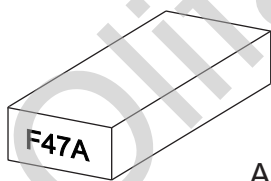
FULL VERSION INSTRUCTION

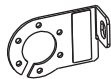

śruba	Nm	M6	M8	M10	M12	M14	M16
klasa 8.8		9,9	24	48	83	132	200
klasa 10.9		14	34	67	117	185	285

 0 km →  1000 km



1		x 1		7	M 12x35	x 4
				8	M 8x40	x 4
2		x 1		10	∅ 13	x 4
				11	∅ 30x∅10.5x2.5 10 DIN 9021	8
3		x 1		12	∅ 24x∅8.4x2 8 DIN 9021	6
				13	∅ 12.2	x 4
4		x 1		14	∅ 10.2	x 4
				15	∅ 8.2	x 6
5		x 1		16	M 12	x 4
				17	M 10	x 4
6		x 1		18	M 8	x 4
				Art.nr-KL1F47A		
Art.nr-BL1F47A						

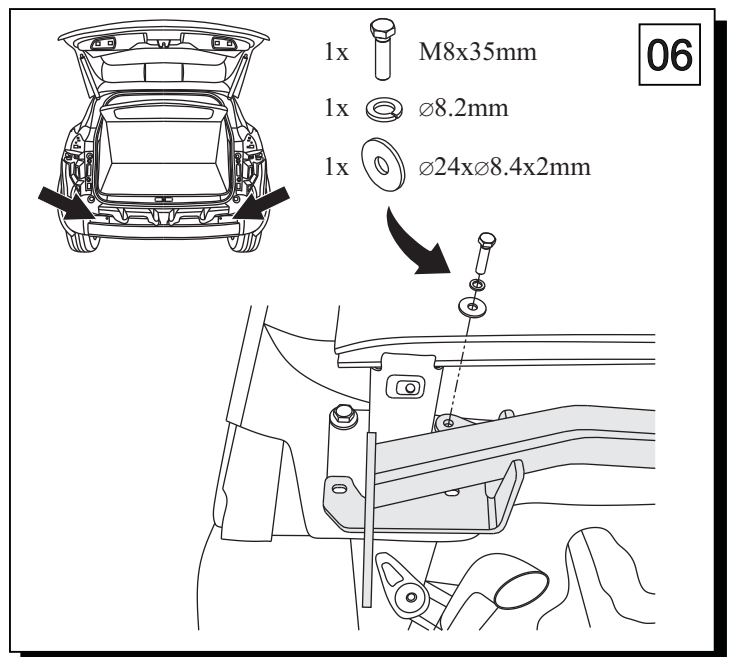
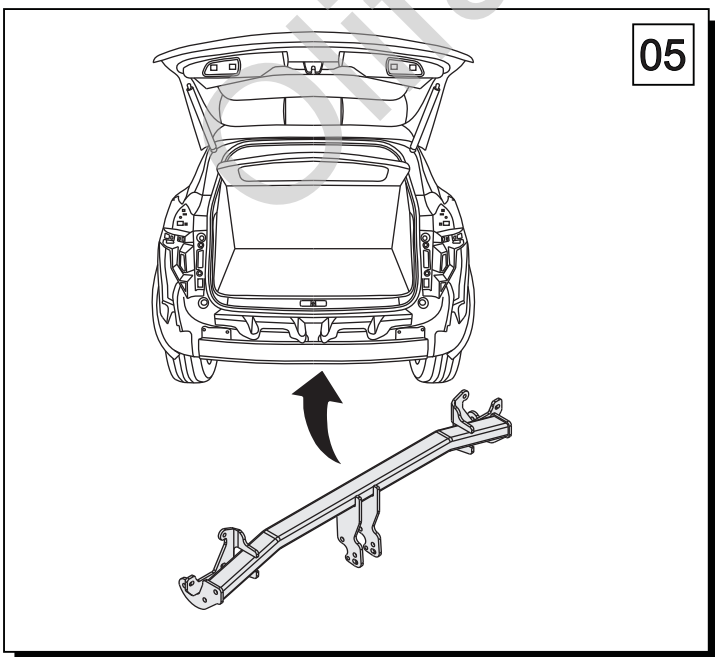
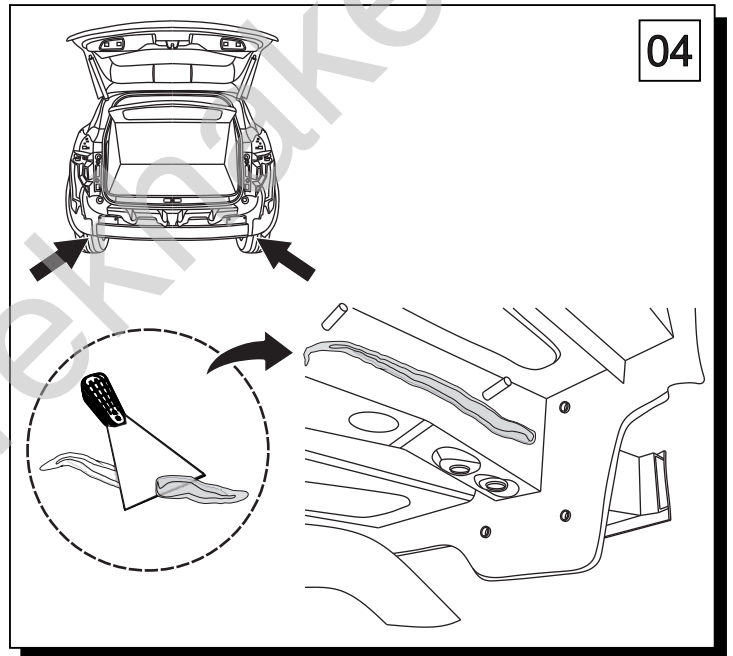
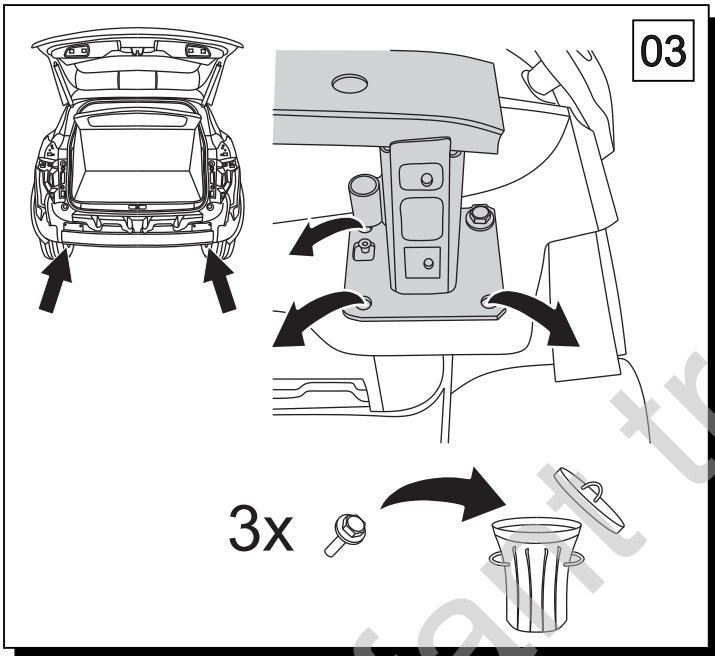
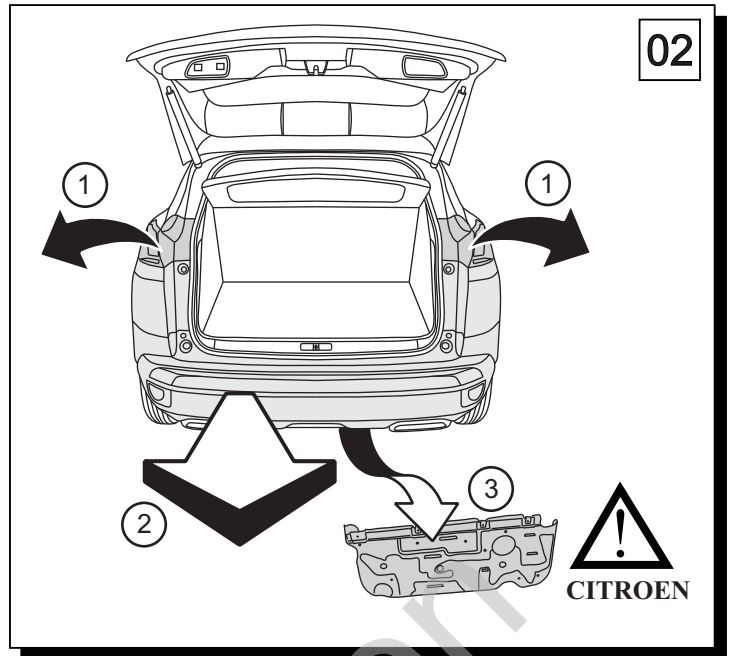
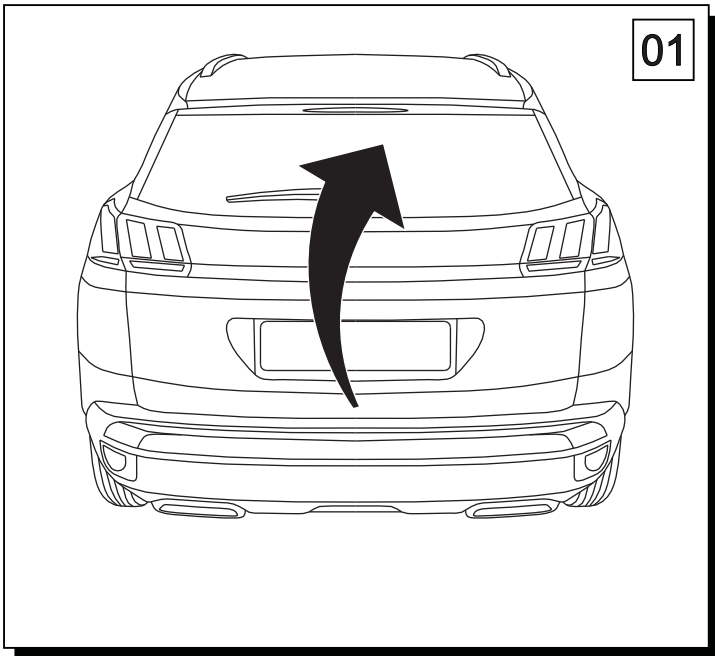

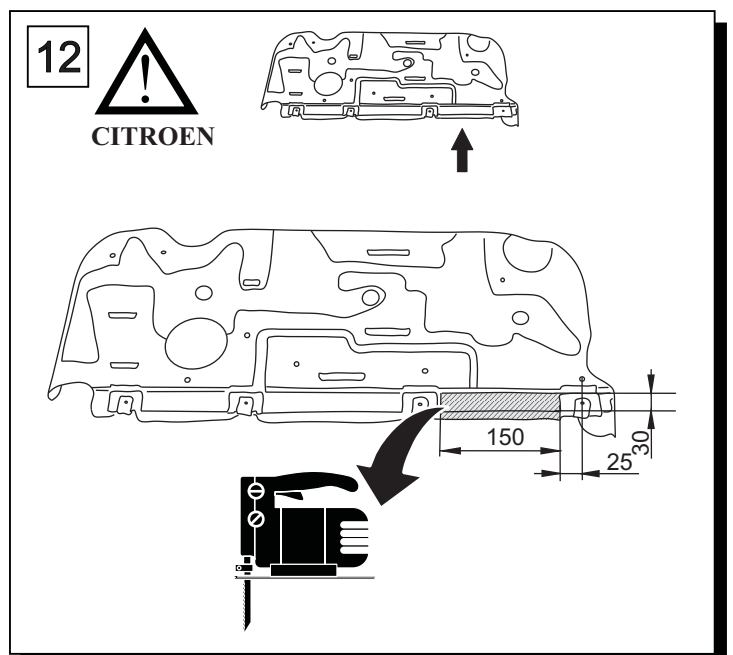
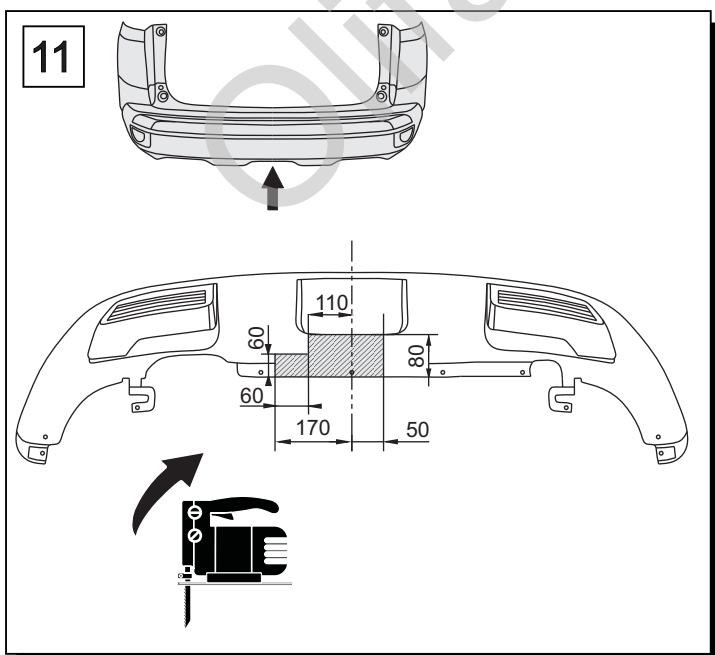
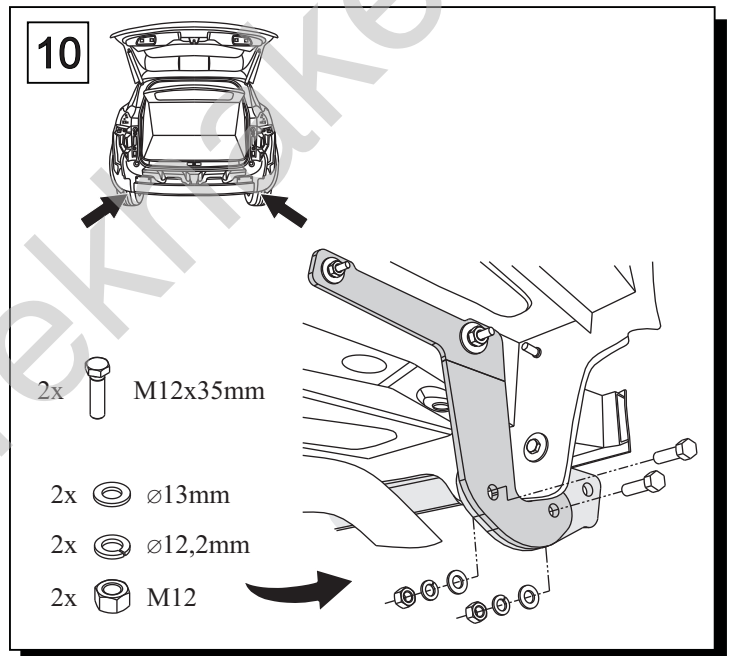
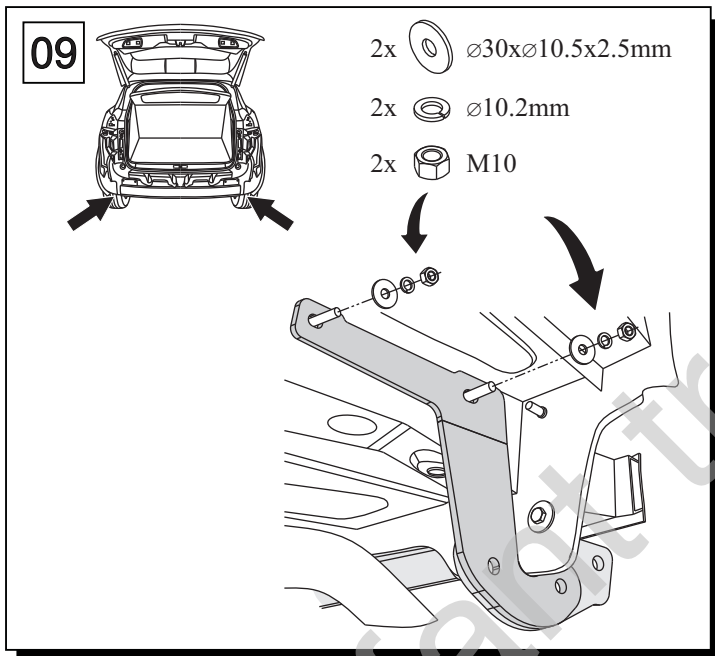
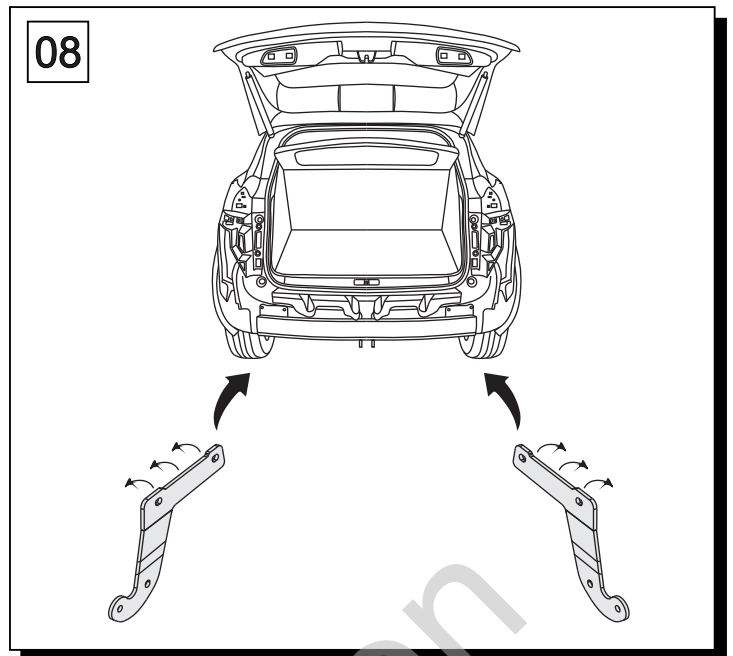
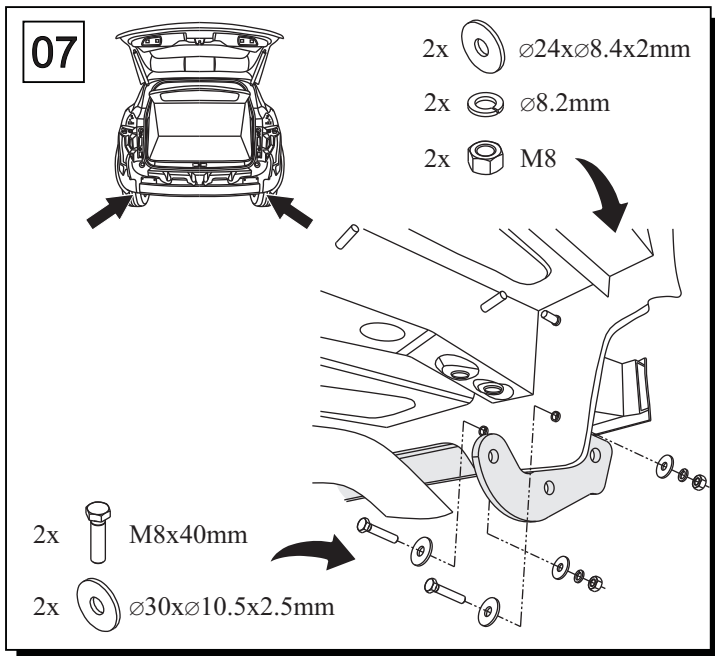

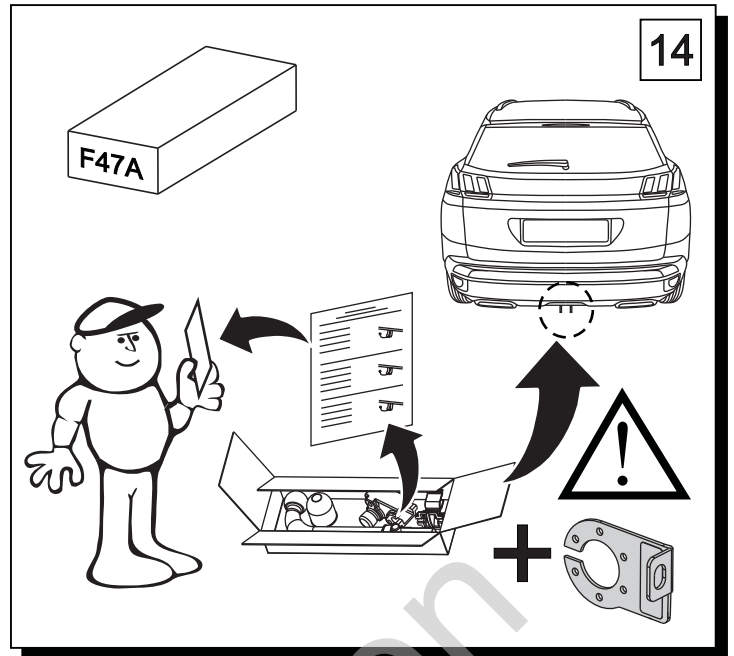
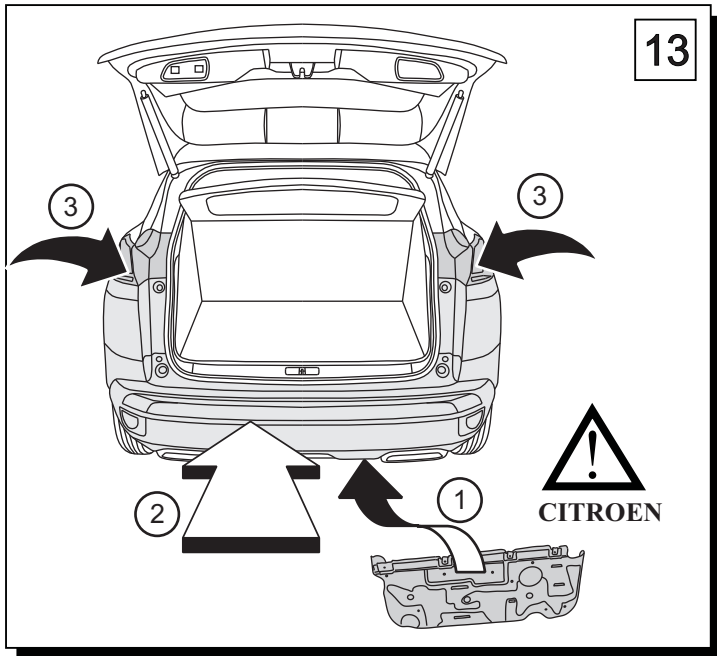

Olifant trekhaken