

# AUTO-HAK Sp. z o.o.

ul. Słoneczna 16K 76-200 SŁUPSK  
POLAND

tel/fax +48 59 8 414 414; +48 59 8 414 413

e-mail: [office@autohak.com.pl](mailto:office@autohak.com.pl)

[www.autohak.com.pl](http://www.autohak.com.pl)



# AUTO-HAK

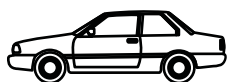

**PEUGEOT 2008  
SUV**

Cat. no:

**F43A**



**04.2013 → 12.2019**



**E20-55R-01 4615**



**7,2 kN**



**R=1300 kg**



**S=60 kg**



**2h**

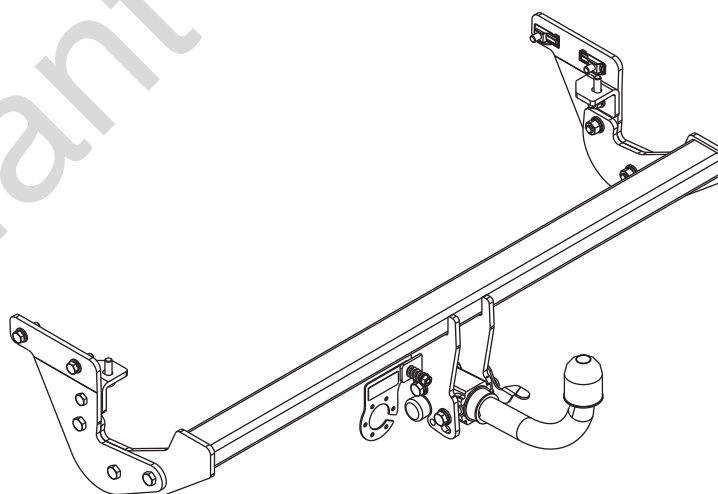

**M6 - 11 Nm  
M10 - 50 Nm  
M14 - 138 Nm**

**M8 - 25 Nm  
M12 - 87 Nm  
M16 - 210 Nm**



**0 km →**



**1000 km**

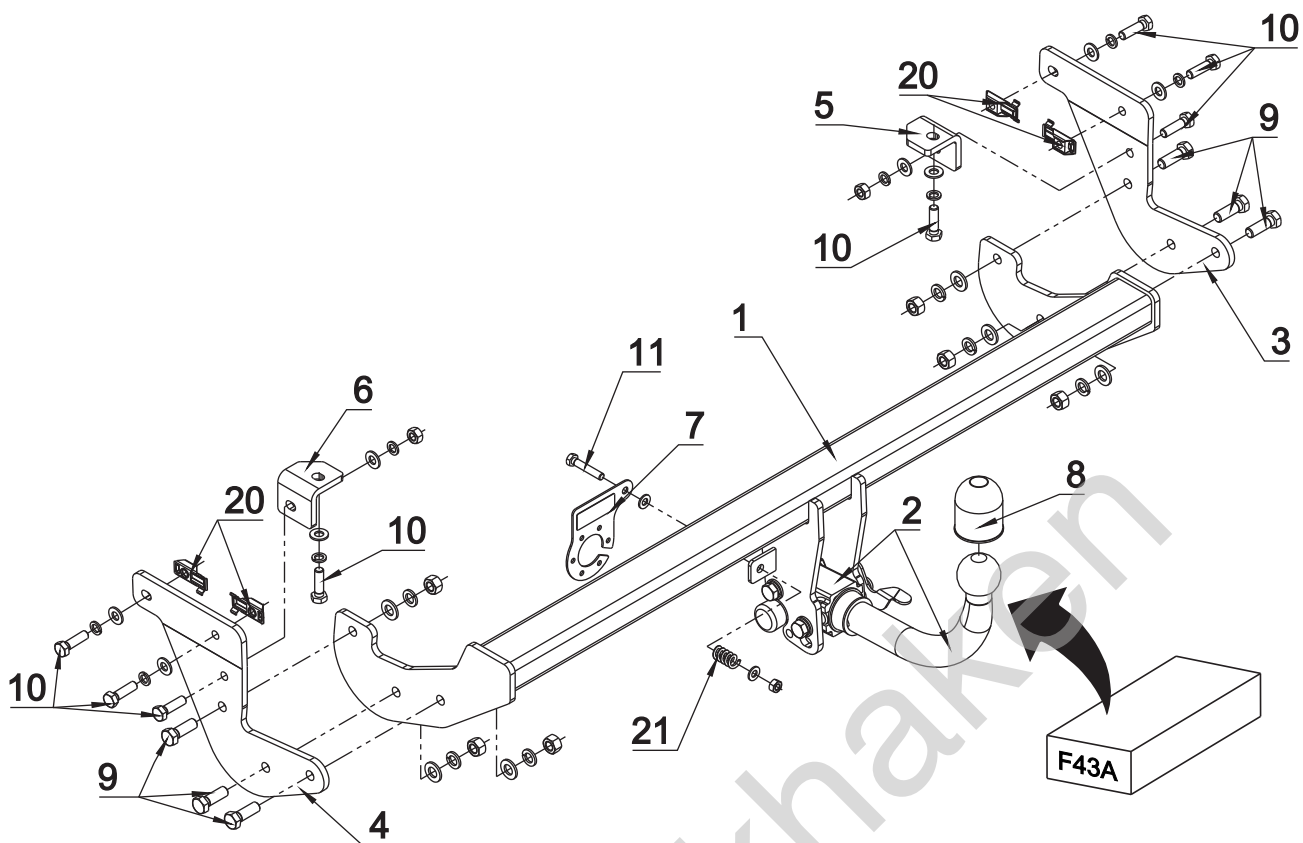

1	x 1		9	M12x35	x 6
2	x 1	 Art.nr-Z100 Art.nr-KL1F43A	10	M10x35	x 8
			11	M8x45	x 1
3	x 1		12	∅ 13	x 6
			13	∅ 10.5	x 8
4	x 1		14	∅ 8.4	x 2
			15	∅ 12.2	x 6
5	x 1		16	∅ 10.2	x 8
			17	M12	x 6
6	x 1		18	M10	x 2
			19	M8	x 1
7	x 1	 Art.nr-BL1F43A	20	M10	x 4
			21		x 1
8	x 1				

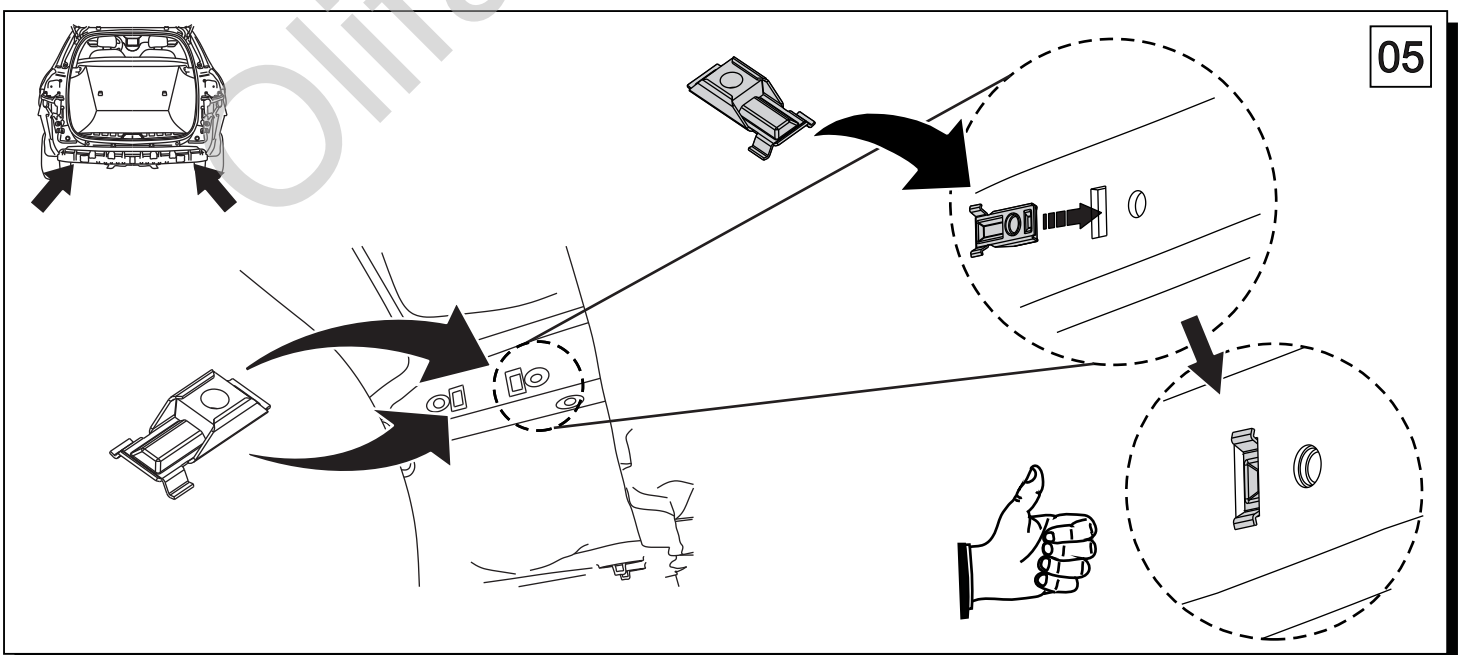
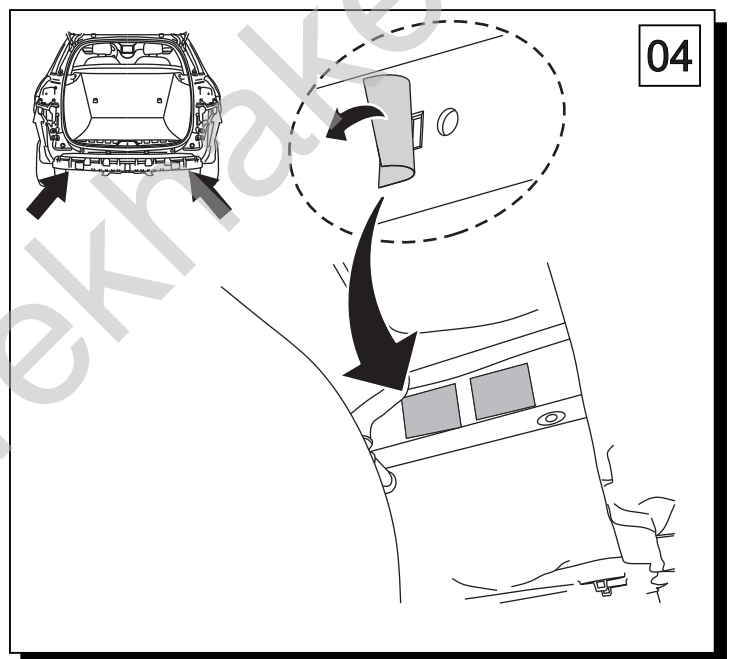
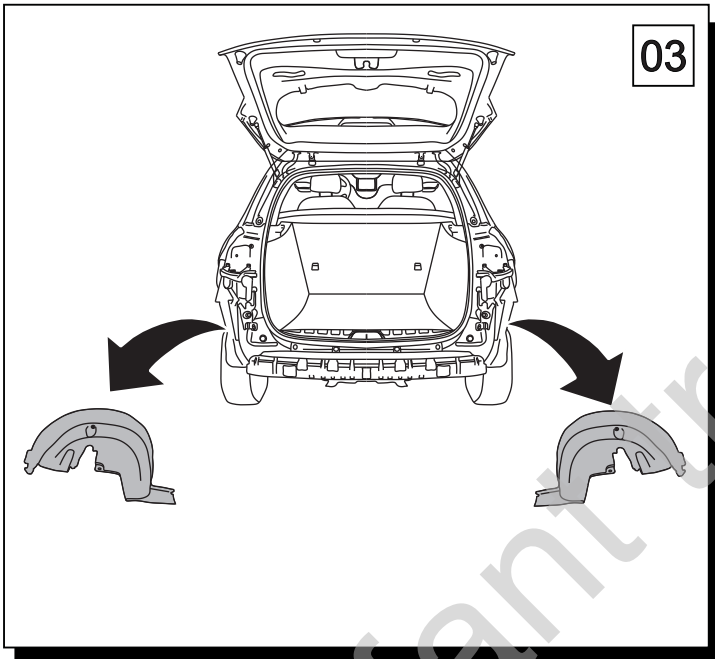
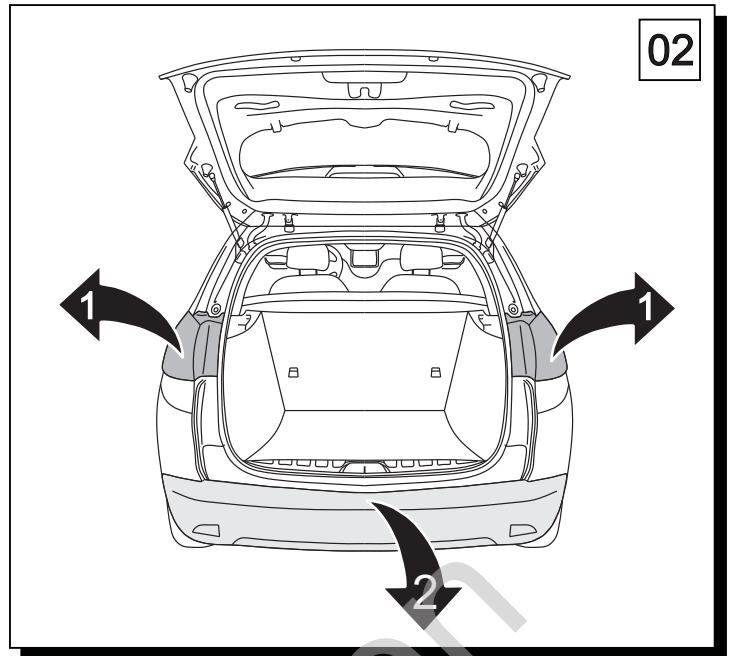
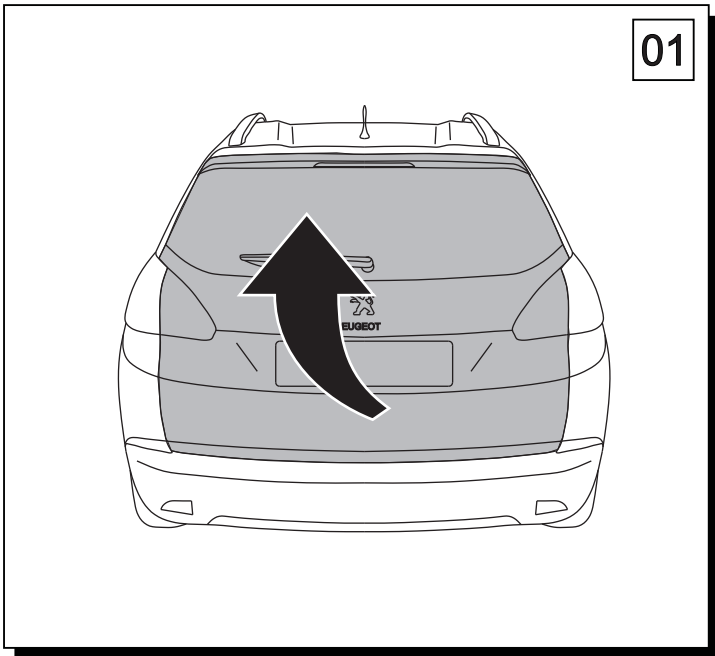

06

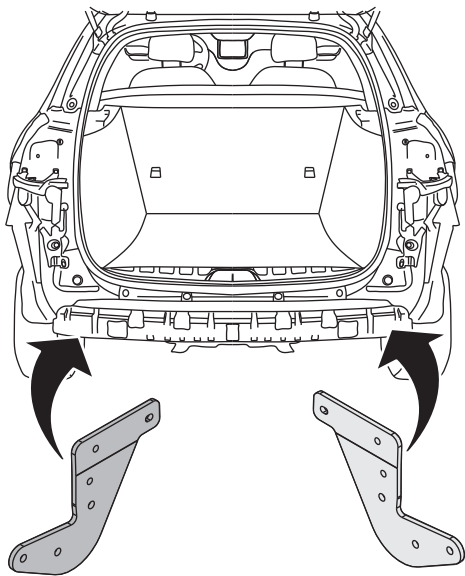

07

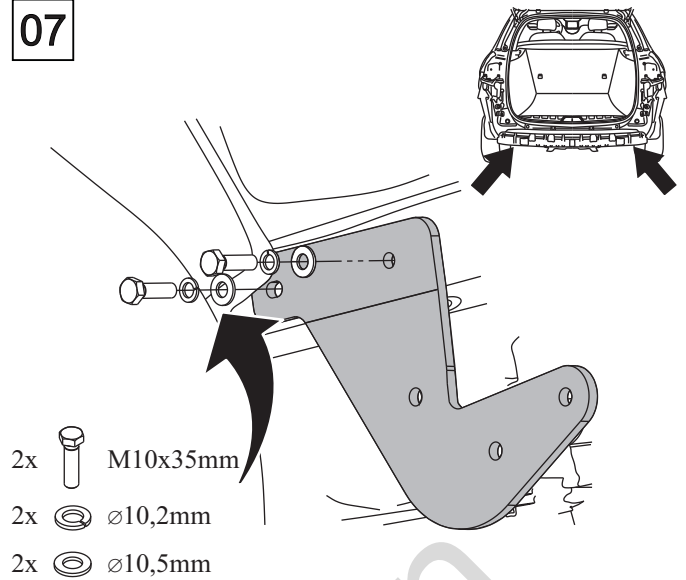

08

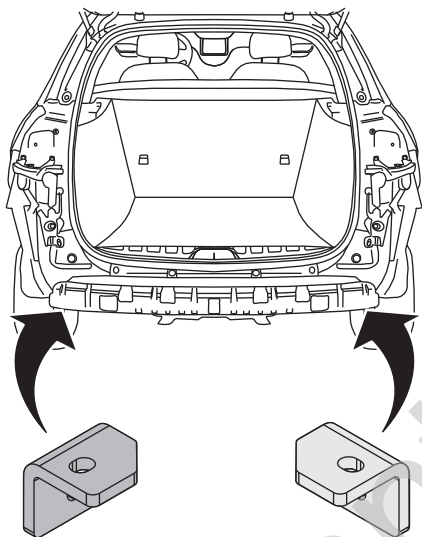

09

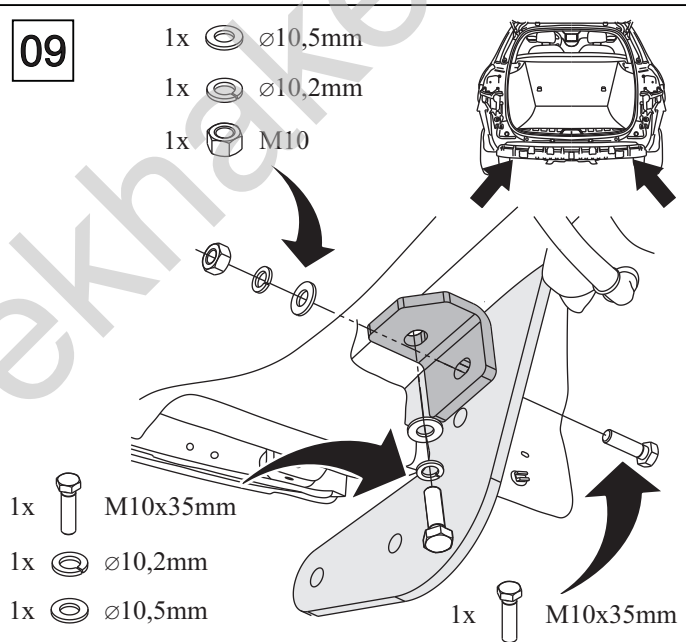

10

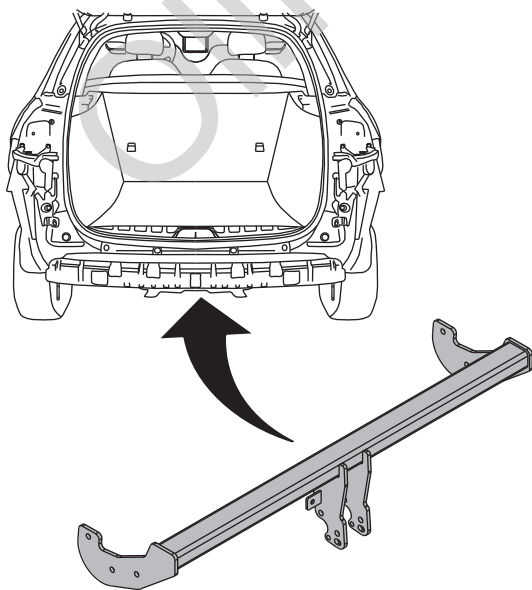

11

