

AUTO-HAK Sp. z o.o.

ul. Słoneczna 16K 76-200 SŁUPSK
POLAND

tel/fax +48 59 8 414 414; +48 59 8 414 413

e-mail: office@autohak.com.pl

www.autohak.com.pl



AUTO-HAK

PEUGEOT 208 I 3/5D

04.2012 → 05.2019

CITROEN C3 III 5D

07.2016 →

Cat. no:

F41A

e20 e20*94/20*1679*00



2h

D 8,1 kN

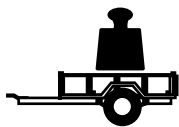
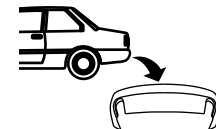

R=1200 kg

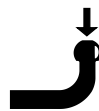

S=50 kg



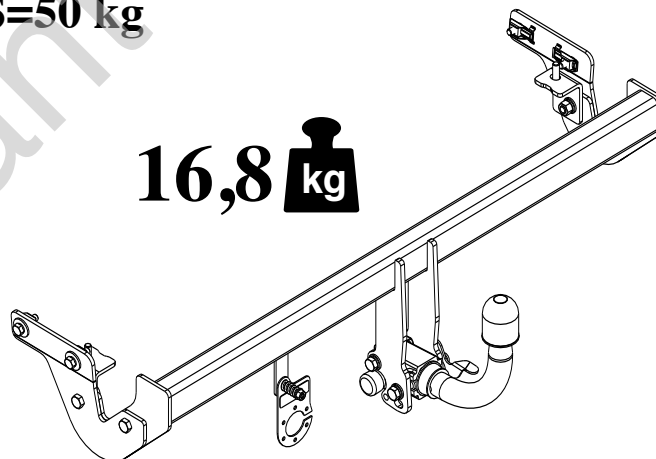



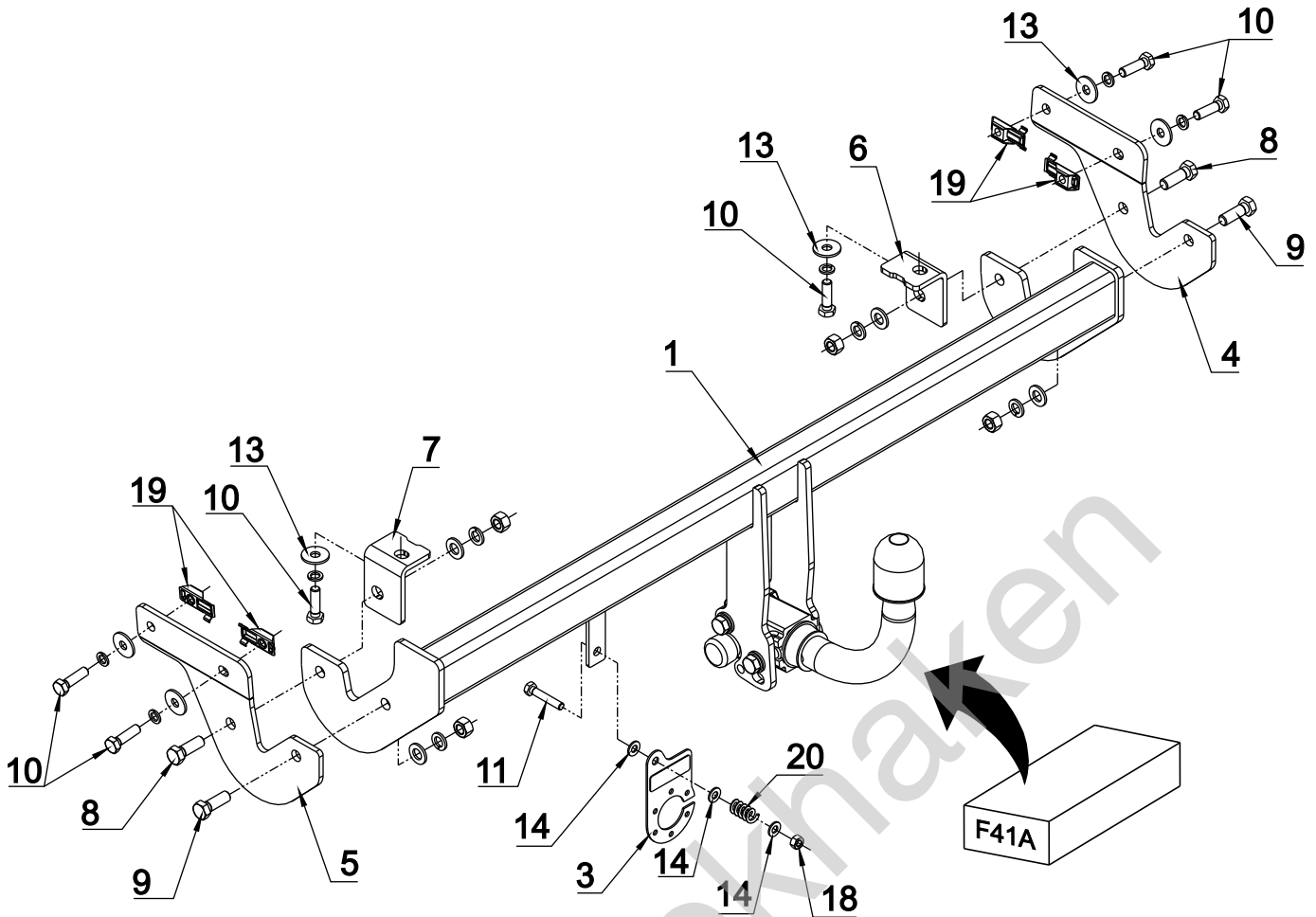

16,8 kg

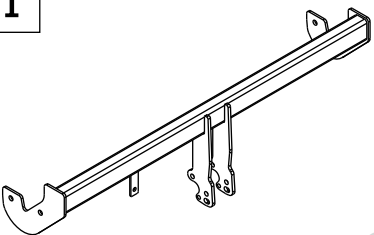

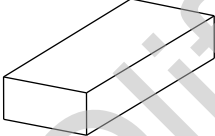
śruba Nm	M6	M8	M10	M12	M14	M16
klasa 8.8	9,9	24	48	83	132	200
klasa 10.9	14	34	67	117	185	285

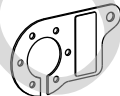
0 km → **1000 km**

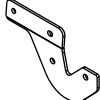
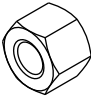
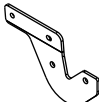
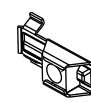
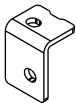
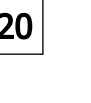
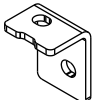

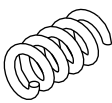
1		x1		8 M12x45	x2
2	 Art.nr-KL1F41A	x1		9 M12x35	x2
				10 M10x35	x6
3	 Art.nr-BL1F41A	x1		11 M8x45	x1
				12 \varnothing 13	x4
4		x1		13 \varnothing 30x \varnothing 10.5x2.5 10 (DIN 9021)	x6
				14 \varnothing 8.4	x3
5		x1		15 \varnothing 12.2	x4
				16 \varnothing 10.2	x6
6		x1		17 M12	x4
				18 M8	x1
7		x1		19 M10	x4
				20	

01

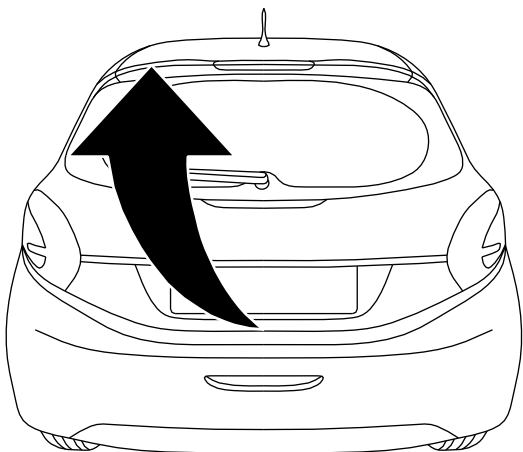

02

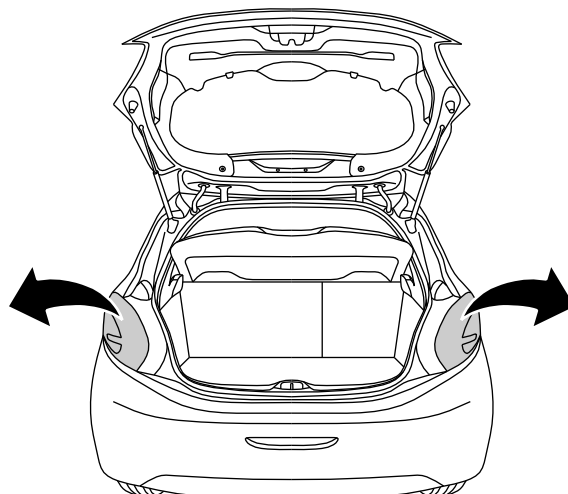

03

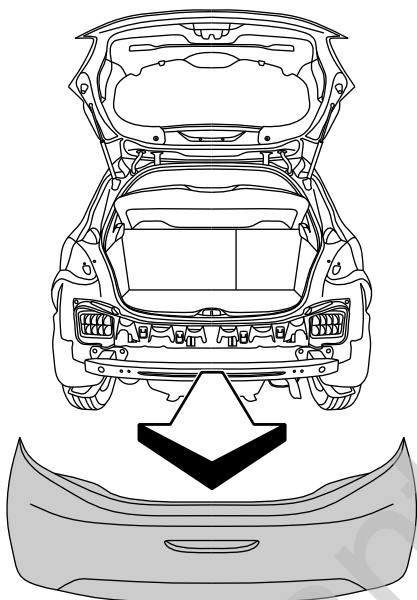

04

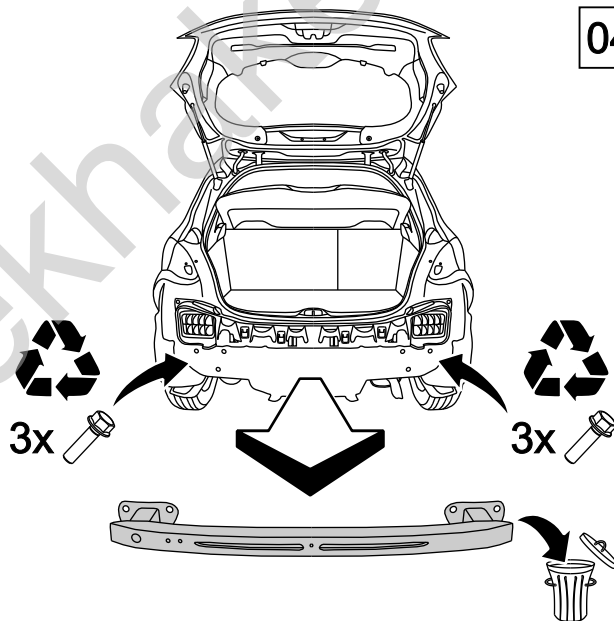

05

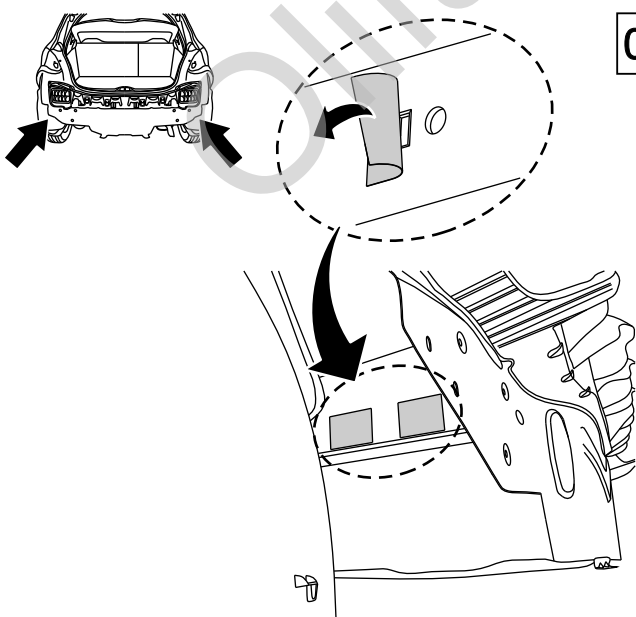

06

