

AUTO-HAK Sp. z o.o.

ul. Słoneczna 16K 76-200 SŁUPSK
POLAND

tel/fax +48 59 8 414 414; +48 59 8 414 413

e-mail: office@autohak.com.pl

www.autohak.com.pl



AUTO-HAK

PEUGEOT 508 Break/SW (Kombi)



(~~GT, HDi 2.2~~)

Nr kat.

F40A



03.2011 → 08.2018

e20

e20*94/20*1533*00



2h

D

10,19 kN



R=1900 kg



S=75 kg



21,3 kg

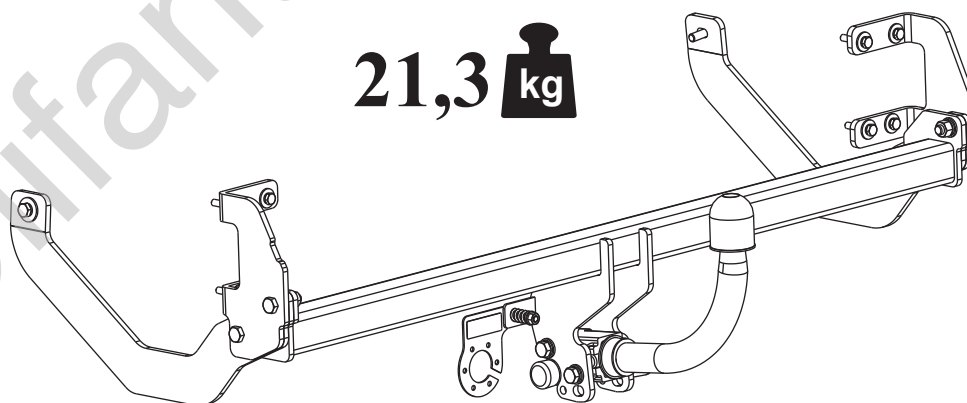

śruba	Nm	M6	M8	M10	M12	M14	M16
klasa 8.8		9,9	24	48	83	132	200
klasa 10.9		14	34	67	117	185	285



0 km



1000 km

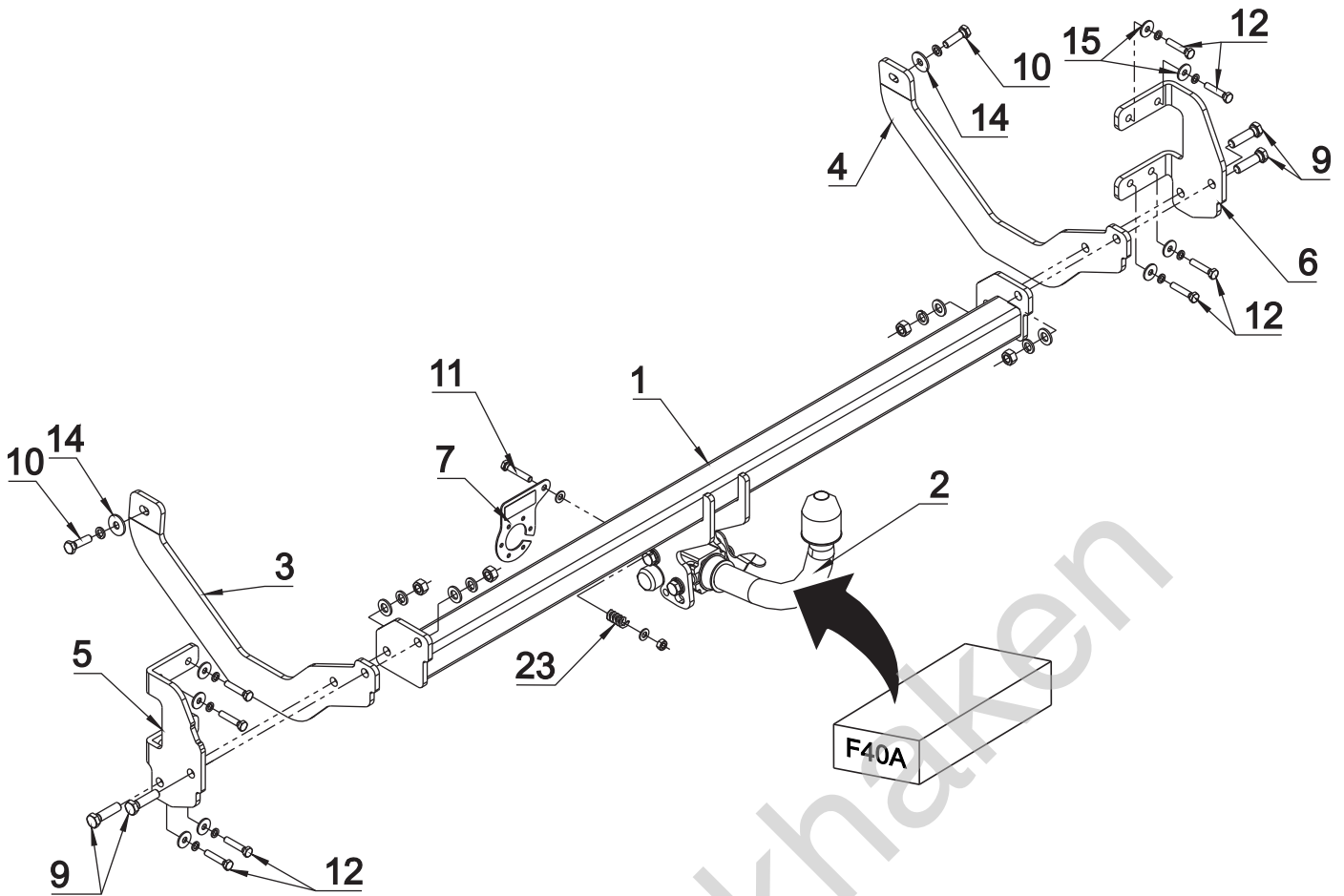

1	x1		9	M12x45	x4
2	x1	 Art.nr-KL1F40A	10	M10x35	x2
			11	M8x45	x1
3	x1		12	M8x40	x8
			13	∅ 4	x6
4	x1		14	∅ 30x∅10.5x2.5 10 (DIN 9021)	x2
			15	∅ 24x∅8.5x2 8 (DIN 9021)	x8
5	x1		16	∅ 8.4	x2
			17	∅ 12.2	x4
6	x1		18	∅ 10.2	x2
			20	∅ 8.2	x8
7	x1		21	M12	x4
			22	M8	x1
8	x1		23		
			24		x1

