

FITTING INSTRUCTION

Clamp mark in acc. with		Cables joining
ISO	PN	
1	L	Left directional lights
2	+	Rear fog lights
3	31	Ground
4	R	Right directional lights
5	58R	Right side parking lights
6	54	Stoplights
7	58L	Left side parking lights

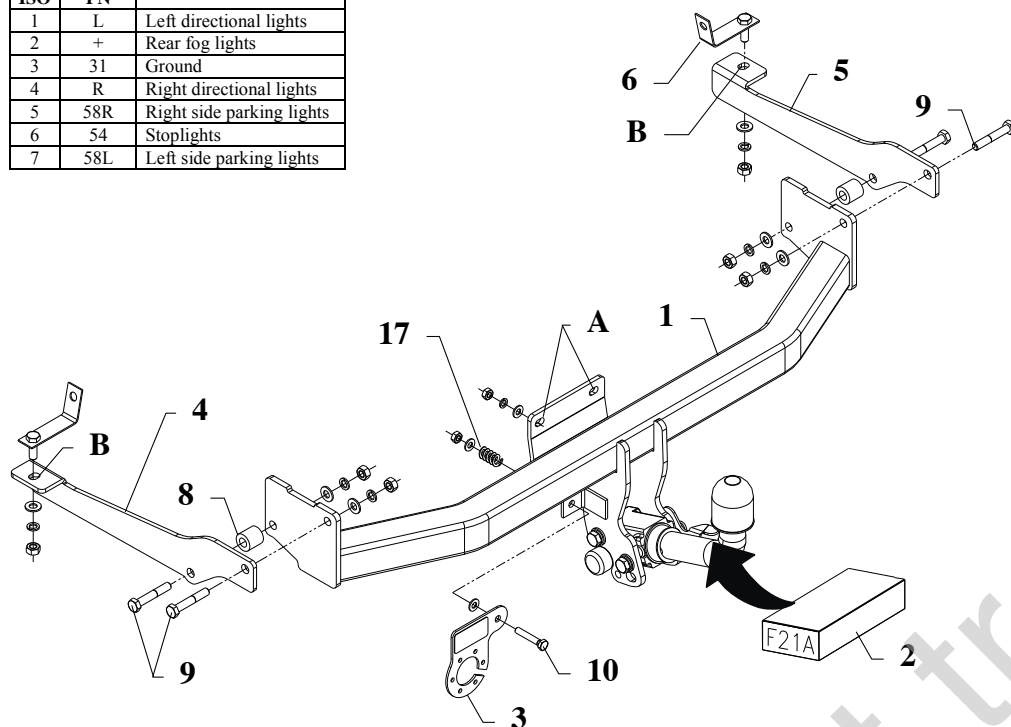

This towbar is designed to assembly in following cars:
PEUGEOT 306 3/5 doors produced since 03.1993 till 04.2001, catalogue no. **F21A** and is prepared to tow trailers max total weight **1400 kg** and max vertical load **50 kg**.

From manufacturer

Thank you for buying our product. Their reliability has been confirmed in many tests. Reliability of towbar depends also on correct assembly and right operation. For this reasons we kindly ask to read carefully this instruction and apply to hints.

The towbar should be install in points described by a car producer.

The instruction of the assembly

1. Take the spare wheel out of the boot.
2. Find ellipsal plastic covers on the left and right side, then put through these holes bolts M10 together with elements (pos. 6)
3. Lower the silencer and unscrew the handle from the rear panel.
4. Position the main bar of the towabr at the bottom of the car and through the holes (pos. A) hang on the special bolts in the rear panel and fit it loosely with M8.
5. Slide the supports (pos. 4 and 5) outside the chassis member and fit it with the main bar of the towbar (pos. 1) using bolts M10x60mm – (pos. 9) – as it shown on the drawing.
6. Fit the supports with bolts M10 (pos. 6) through the holes (pos. B) using nut M10.
7. Fit the handle together with plain washer $\varnothing 35 \times \varnothing 12 \times 6 \text{mm}$ (pos. 7).
8. Fix body of the automat according to supplied instruction.
9. Fix the socket plate (pos. 3) as shown on the drawing.
10. Tighten all nuts and bolts according to the torque shown in the table.
11. Connect the electric wires according to the instructions of the car.
12. Complete the paint cover of towbar (during the mounting paint cover could be destroyed).

Torque settings for nuts and bolts (8,8):	
M 8 - 25 Nm	M 10 - 55 Nm
M 12 - 85 Nm	M 14 - 135 Nm



NOTE

After install the towbar you should get adequate note in registration book (at authorised service station).The car should be equipped with:

- Indicators
- Tow mirrors

After 1000km check all bolts and nuts. The ball of towbar must be always kept clear and conserve with a grease.

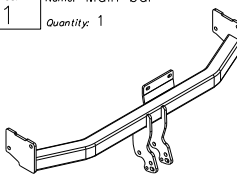
Towbar accessories:

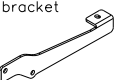
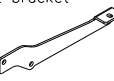
Pos. 1 Name: Main bar Quantity: 1	Pos. 6 Name: Jib with the bolt Quantity: 2 Dim.: M10x30mm	Pos. 12 Name: Nut 8 B Quantity: 2 Dim.: M8
	Pos. 7 Name: Washer Quantity: 1 Dim.: Ø35xØ12x6mm	Pos. 13 Name: Plain washer Quantity: 6 Dim.: Ø 10,5 mm
Pos. 2 Name: Tow ball Quantity: 1	Pos. 8 Name: Distance sleeve Quantity: 2 Dim.: Ø25x6, L=25mm	Pos. 14 Name: Plain washer Quantity: 3 Dim.: Ø 8,5 mm
	Pos. 9 Name: Bolt 8,8 B Quantity: 4 Dim.: M10x60mm	Pos. 15 Name: Spring washer Quantity: 6 Dim.: Ø 10,2 mm
Pos. 3 Name: Socket plate Quantity: 1	Pos. 10 Name: Bolt 8,8 B Quantity: 1 Dim.: M8x45mm	Pos. 16 Name: Spring washer Quantity: 1 Dim.: Ø 8,2 mm
Pos. 4 Name: Left bracket Quantity: 1	Pos. 11 Name: Nut 8 B Quantity: 6 Dim.: M10	Pos. 17 Name: Spring Quantity: 1 PCS.: 1
Pos. 5 Name: Right bracket Quantity: 1		



PPUH AUTO-HAK S. J.

Produkcja Haków Holowniczych
Henryk & Zbigniew Nejman
76-200 SŁUPSK ul. Słoneczna 16K
tel/fax (059) 8-414-414; 8-414-413
E-mail: office@autohak.com.pl
www.autohak.com.pl

Towing hitch (without electrical set)

Class: **A50-X** Cat. no. **F21A**

Designed for:

Manufacturer: **PEUGEOT**

Model: **306**

Type: **3/5 doors**

produced since 03.1993 till 04.2001

Technical data:

D-value: 7,47 kN

maximum trailer weight: **1400 kg**

maximum vertical cup load: **50 kg**

Approval number according to Directive 94/20/EC: e20*94/20*1088*00

Foreword

This towbar is designed according to rules of safety traffic regulations. The towing hitch is a safety component and can be install only by qualified personnel. Any alteration or conversion of the towing hitch is prohibited and would lead to cancellation of design certification. Remove insulating compound and underseal from vehicle (if present) in the area of the matting surfaces of the towing hitch.

The vehicle manufacturer's specifications regarding trailer load and max. vertical cup load are decisive for driving, and values for the towing hitch cannot be exceeded.

D-value formula:

$$\frac{\text{Max trailer weight [kg]} \times \text{Max vehicle weight [kg]}}{\text{Max trailer weight [kg]} + \text{Max vehicle weight [kg]}} \times \frac{9,81}{1000} = D \text{ [kN]}$$