

PPUH AUTO-HAK Sp.J.

Henryk i Zbigniew Nejman
ul. Słoneczna 16K 76-200 SŁUPSK
POLAND

tel/fax +48 59 8 414 414; +48 59 8 414 413

e-mail: office@autohak.com.pl

www.autohak.com.pl



AUTO-HAK

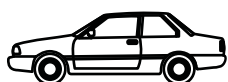

**PEUGEOT 306 Break/SW
KOMBI**

Cat. no:

F15A



05.1997 → 02.2002

e20

e20*94/20*1089*00



2h

D

7,0 kN



R=1200 kg



S=52 kg

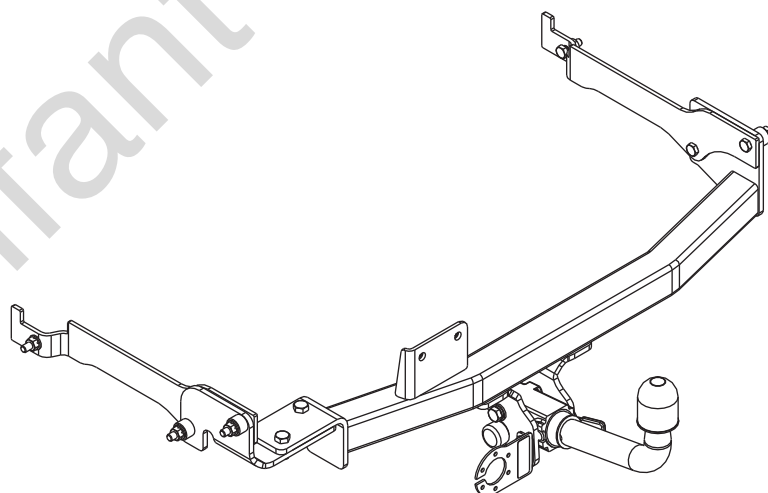

M6 - 11 Nm
M10 - 50 Nm
M14 - 138 Nm

M8 - 25 Nm
M12 - 87 Nm
M16 - 210 Nm









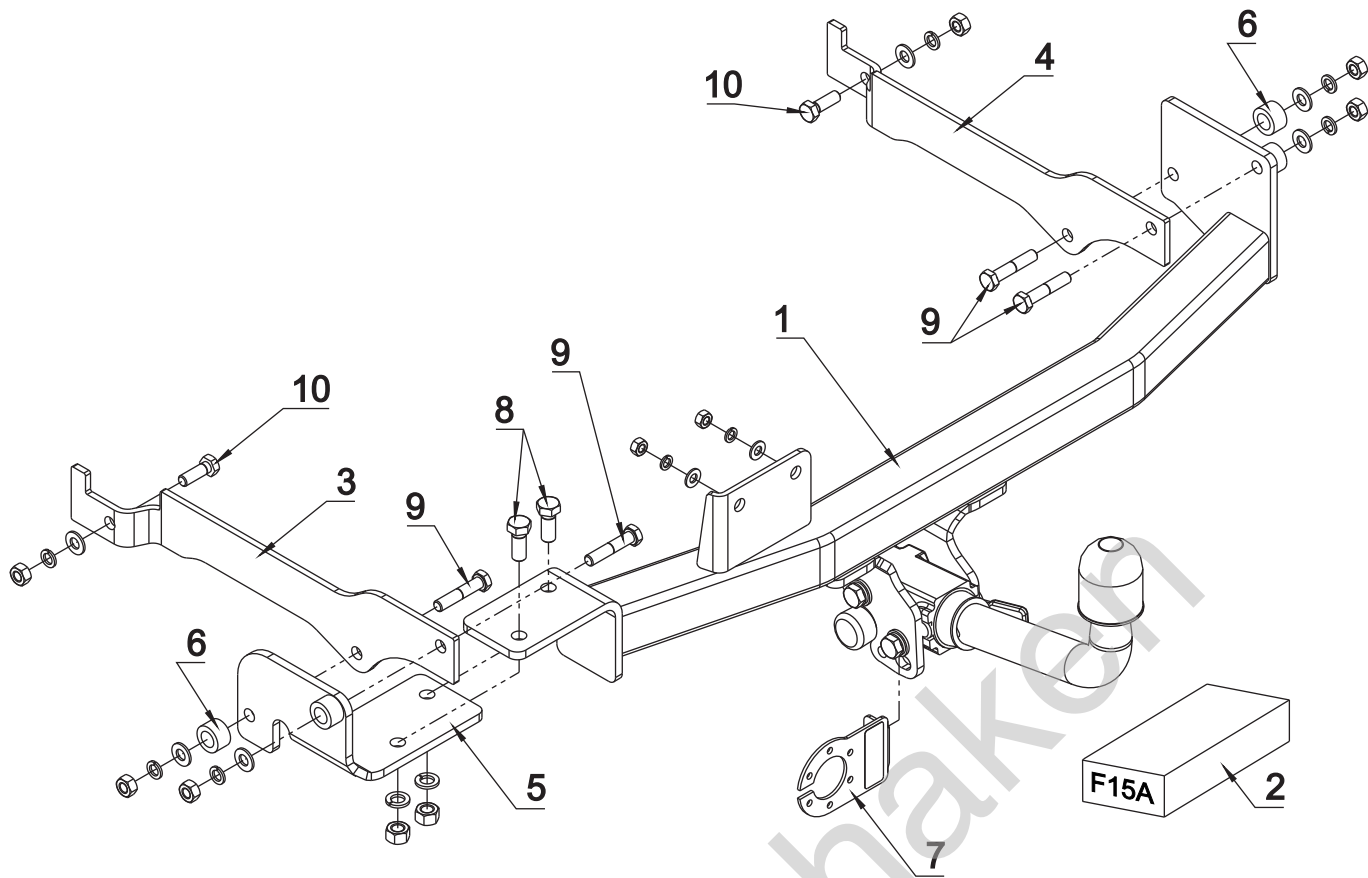

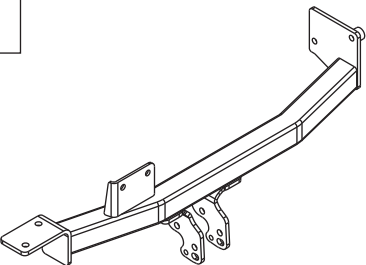
0 km →

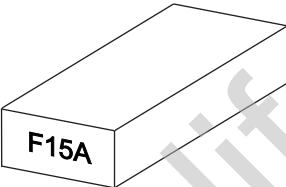

1000 km

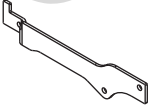
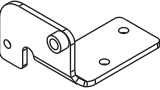

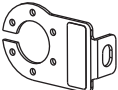
	x1		8	M12x30	x2
			9	M10x50	x4
			10	M10x30	x2
			11	∅ 10.5	x6
 <p>Art.nr-KL1F15A</p>	x1		12	∅ 8.5	x2
			13	∅ 12.2	x2
			14	∅ 10.2	x6
			15	∅ 8.2	x2
			16	M12	x2
	x1		17	M10	x6
			18	M8	x2
	x1				
	x1				
 <p>∅25x15mm L=15mm</p>	x1				
 <p>Art.nr-BL1F15A</p>	x1				

