

FITTING INSTRUCTION

Clamp mark in acc. with		Cables joining
ISO	PN	
1	L	Left directional lights
2	+	Rear fog lights
3	31	Ground
4	R	Right directional lights
5	58R	Right side parking lights
6	54	Stoplights
7	58L	Left side parking lights

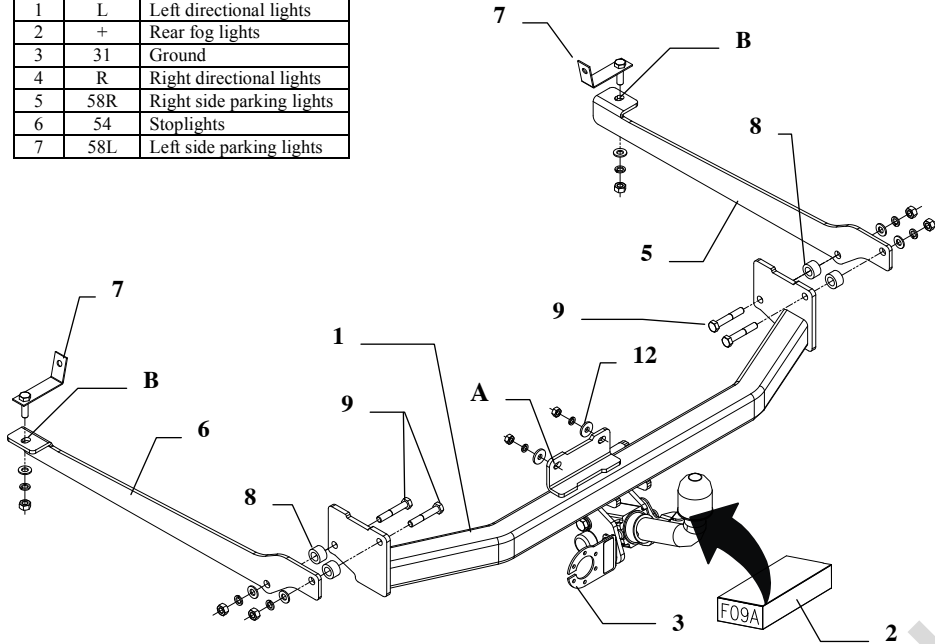

This towbar is designed to assembly in following car:
PEUGEOT 306 4 doors, except Cabrio, produced since 10.1994 till 05.2001, catalogue number **F09A** and is prepared to tow trailers max total weight **1400 kg** and max vertical load **52 kg**.

From manufacturer

Thank you for buying our product. Their reliability has been confirmed in many tests. Reliability of towbar depends also on correct assembly and right exploit. For this reasons we kindly ask to read carefully this instruction and apply to hints.

The towbar should be install in points described by a car producer.

Assembly instructions

1. Take out the spare wheel and carpet from the trunk.
2. Inside the trunk, on the left and right side, take out ellipse, rubber plugs. Next through holes put bolt M10 with the jib (pos. 7).
3. Main bar of the towbar (pos. 1) put below the car and through holes (pos. A) hang on protruding pins (on the back side) and fix by nuts M8 (loosely).
4. From inside of chassis members put side brackets (pos. 5 and 6) and fix it by bolts M10x60mm (pos. 9) through car body, fix to main bar of the towbar (pos. 1) as shown in the figure. Next, using nut M10, fix brackets through holes (pos. B) with bolts M10 with the jib (pos. 7).
5. Fix body of the automat and place tow-ball according to supplied instruction. Note! Remember to place socket plate (pos. 3) as shown on the drawing 1.
6. Tighten all bolts according to the torque shown in the table, fix the muffler and insert plugs inside trunk.
7. Connect electric wires of 7-poles socket according to the instruction of the car. (Recommend to make at authorized service station)
8. Complete paint layer damaged during installation.

Torque settings for nuts and bolts (8,8):

M 8	25 Nm	M 10	55 Nm
M 12	85 Nm	M 14	135 Nm











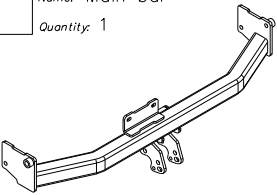
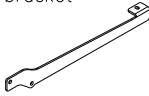

NOTE

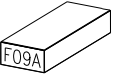
After install the towbar you should get adequate note in registration book (at authorised service station).The car should be equipped with:

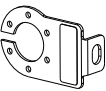
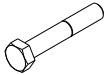
- Indicators
- Tow mirrors

After 1000km check all bolts and nuts. The ball of towbar must be always kept clear and conserve with a grease.

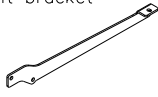
Towbar accessories:

Pos. 1	Name: Main bar Quantity: 1	Pos. 6	Name: Left bracket Quantity: 1	Pos. 12	Name: Plain washer Quantity: 2 Dim.: $\emptyset 25 \times \emptyset 9 \times 3 \text{ mm}$
					
		Pos. 7	Name: Bolt with the jib Quantity: 2	Pos. 13	Name: Plain washer Quantity: 6 Dim.: $\emptyset 10,5 \text{ mm}$
					
Pos. 2	Name: Tow ball Quantity: 1	Pos. 8	Name: Distance sleeve Quantity: 2 Dim.: $\emptyset 25 \times \emptyset 15$ L=15mm	Pos. 14	Name: Spring washer Quantity: 6 Dim.: $\emptyset 10,2 \text{ mm}$
					
Pos. 3	Name: Socket plate Quantity: 1	Pos. 9	Name: Bolt 8,8 B Quantity: 4 Dim.: M10x60mm	Pos. 15	Name: Spring washer Quantity: 2 Dim.: $\emptyset 8,2 \text{ mm}$
					
Pos. 4	Name: Ball cover Quantity: 1	Pos. 10	Name: Nut 8 B Quantity: 6 Dim.: M10		
					
Pos. 5	Name: Right bracket Quantity: 1	Pos. 11	Name: Nut 8 B Quantity: 2 Dim.: M 8		
					



PPUH AUTO-HAK S.J.

Produkcja Haków Holowniczych
Henryk i Zbigniew Nejman
76-200 SŁUPSK ul. Słoneczna 16K
tel/fax (059) 8-414-414; 8-414-413
E-mail: office@autohak.com.pl
www. autohak.com.pl

Towing hitch (without electrical set)

Class: **A50-X** Cat. no. **F09A**

Designed for:

Manufacturer: **PEUGEOT**

Model: **306**

Type: **4 doors, except Cabrio**

produced since 10.1994 till 05.2001

Technical data:

D-value: 7,45 kN

maximum trailer weight: **1400 kg**

maximum vertical cup load: **52 kg**

Approval number according to Directive 94/20/EC: e20*94/20*1087*00

Foreword

This towbar is design according to rules of safety traffic regulations. The towing hitch is a safety component and must be installed only by qualified personnel. Any alteration or conversion to the towinh hitch is prohibited and would lead to cancellation of design certification. Remove insulating compound and underseal from vehicle (if present) in the area of the matting surfaces of the towing hitch. The vehicle manufacturer's specifications regarding trailer load and max. vertical cup load are decisive for driving, and values for the towing hitch cannot be exceeded.

D-value formula:

$$\frac{\text{Max trailer weight [kg]} \times \text{Max vehicle weight [kg]}}{\text{Max trailer weight [kg]} + \text{Max vehicle weight [kg]}} \times \frac{9,81}{1000} = D \text{ [kN]}$$