

# PPUH AUTO-HAK Sp.J.

Henryk i Zbigniew Nejman  
ul. Słoneczna 16K 76-200 SŁUPSK  
POLAND

tel/fax +48 59 8 414 414; +48 59 8 414 413

e-mail: [office@autohak.com.pl](mailto:office@autohak.com.pl)

[www.autohak.com.pl](http://www.autohak.com.pl)



# AUTO-HAK



**MERCEDES E CLASS  
KOMBI(S211), 4-MATIC**

~~AMG~~

Cat. no:

**D39A**



03.2003 → 10.2009

e20

e20\*94/20\*0482\*00



**2h**

**D**

11,5 kN

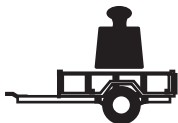

R=2100 kg







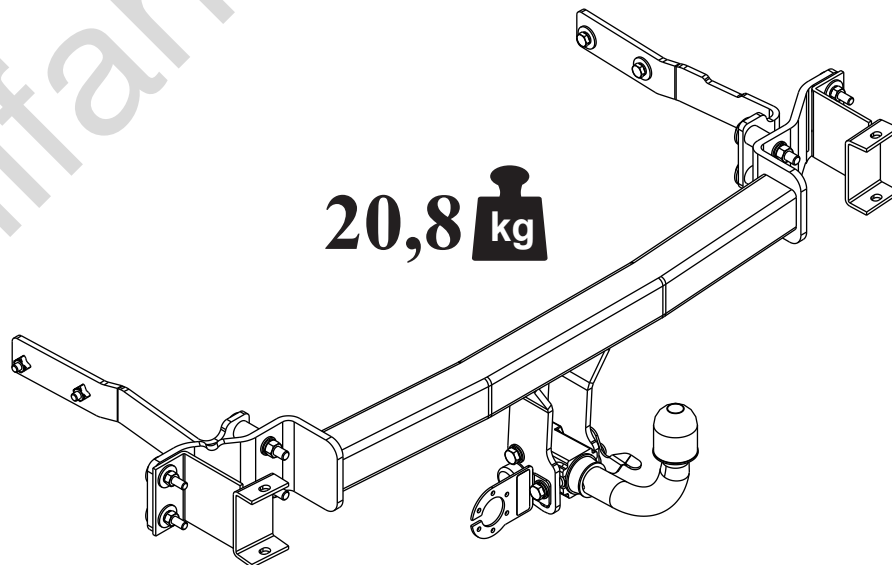

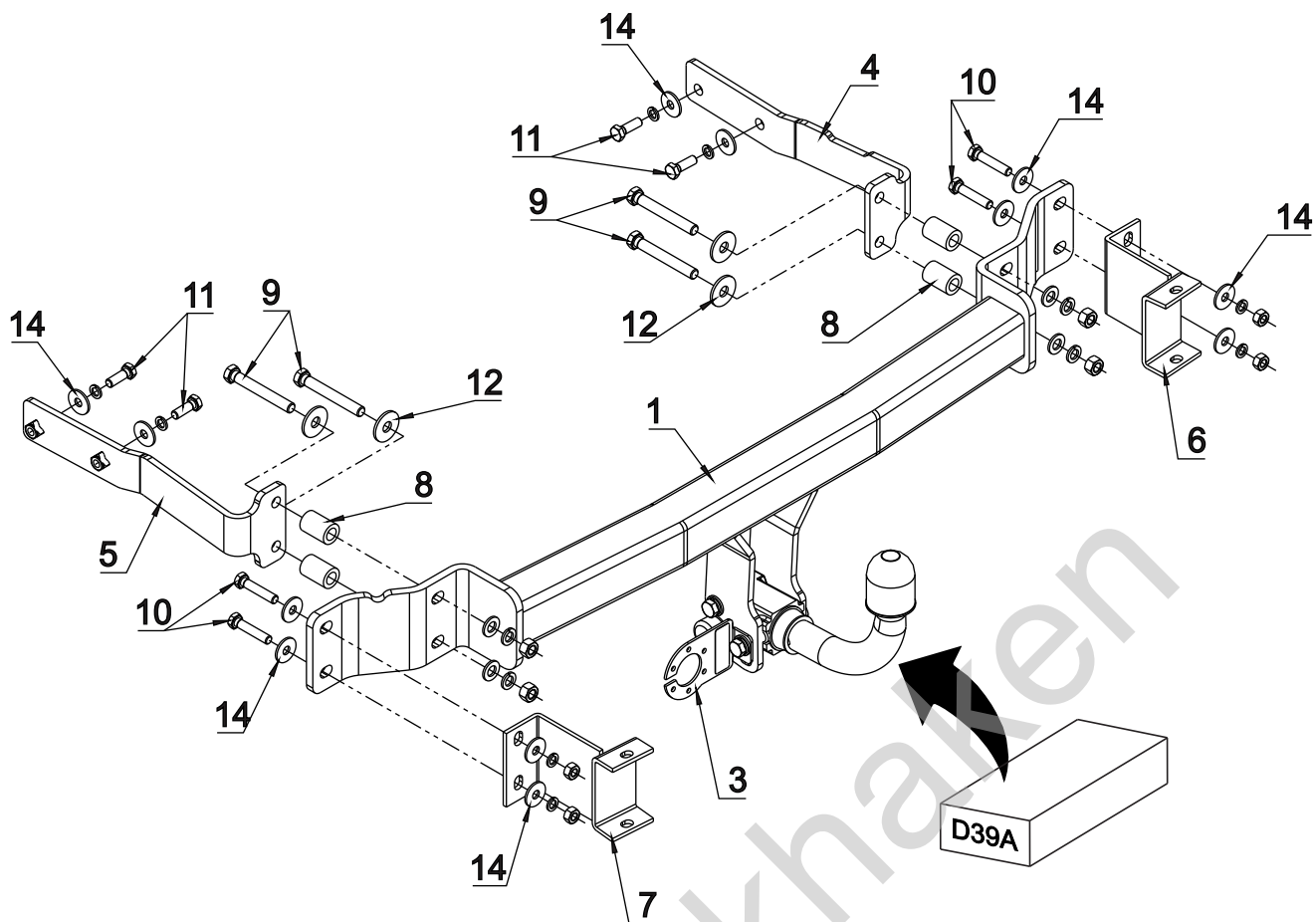

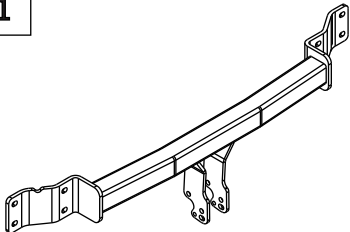
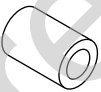

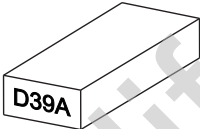

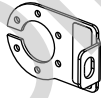

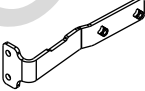
S=88 kg

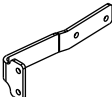
**20,8 kg**





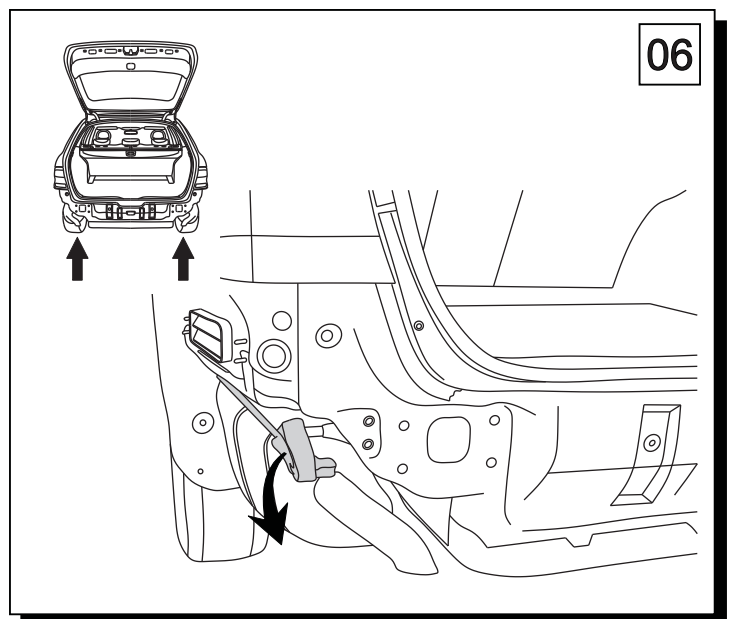
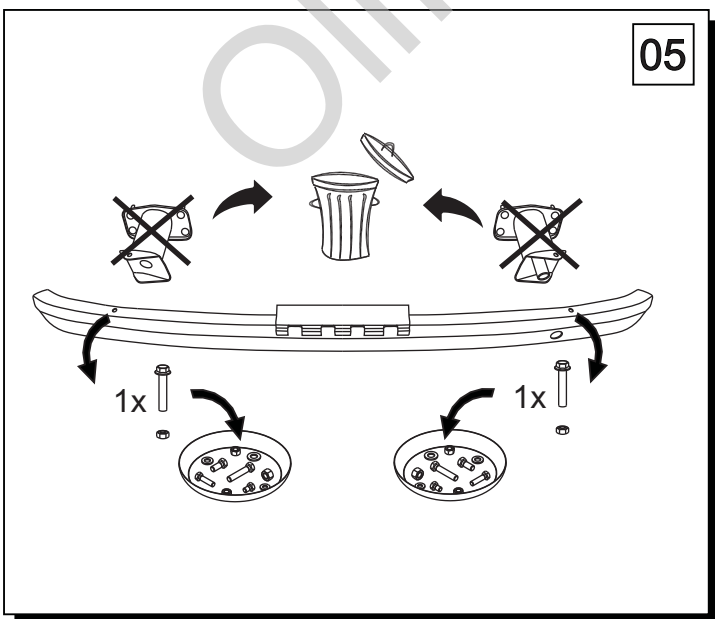
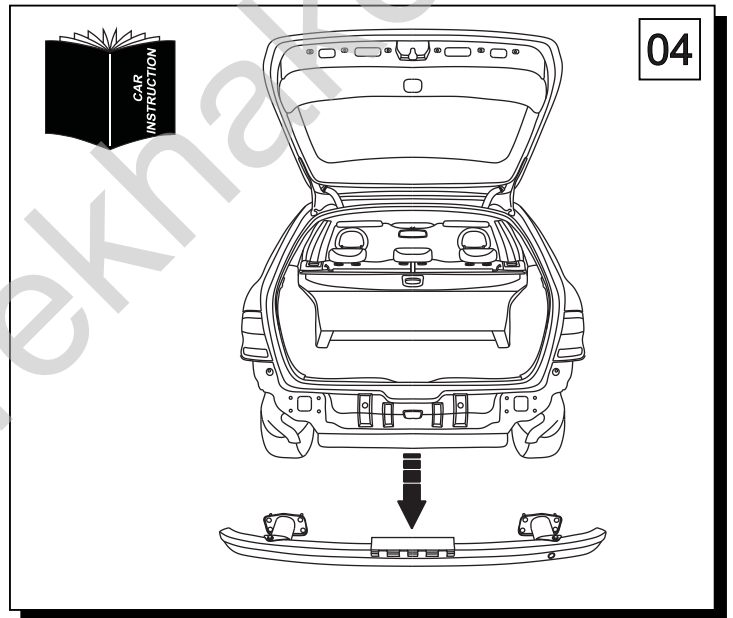
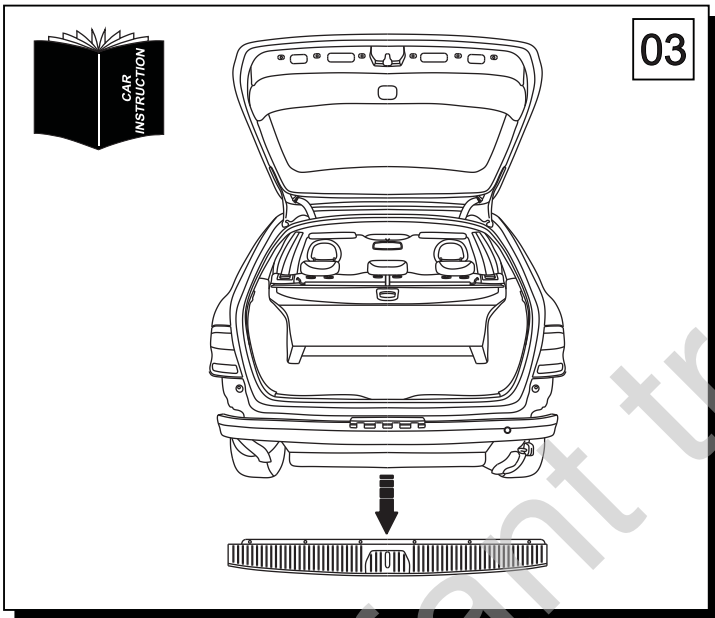
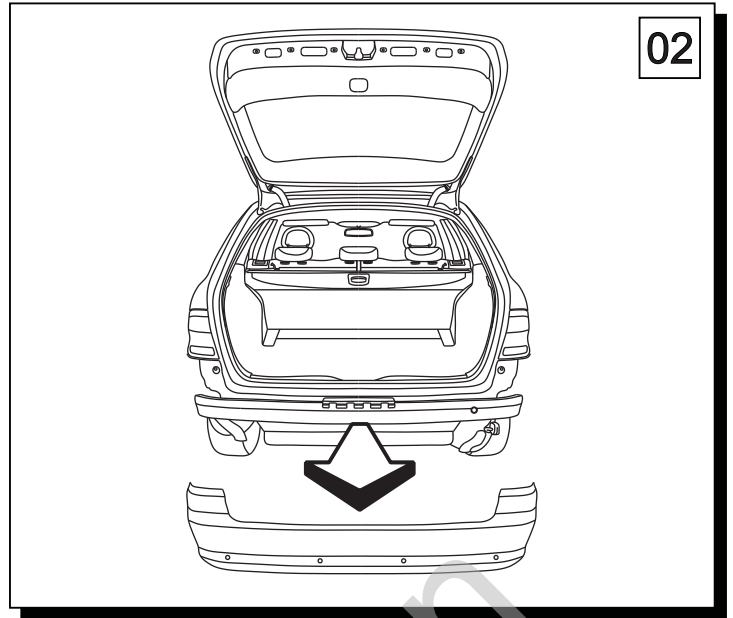
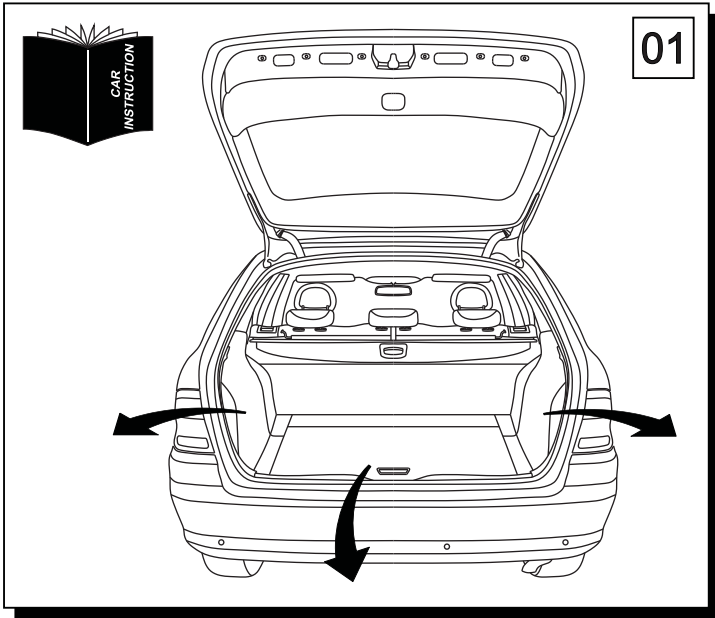

	x1	 	<b>8</b> $\varnothing 25 \times 5 \text{mm}$ L=37mm  <b>9</b> M12x90 <b>10</b> M10x50 <b>11</b> M10x30	<b>x4</b>     <b>x4</b>  <b>x4</b>  <b>x4</b>
	x1		<b>12</b> $\varnothing 37 \times \varnothing 13 \times 3$ 12 DIN 9021	<b>x4</b>
	x1		<b>13</b> $\varnothing 13$	<b>x4</b>
	x1		<b>14</b> $\varnothing 30 \times \varnothing 10.5 \times 2.5$ 10 – DIN 9021	<b>x12</b>
	x1		<b>15</b> $\varnothing 12.2$	<b>x4</b>
	x1		<b>16</b> $\varnothing 10.2$	<b>x8</b>
	x1		<b>17</b> M12	<b>x4</b>
			<b>18</b> M10	<b>x4</b>

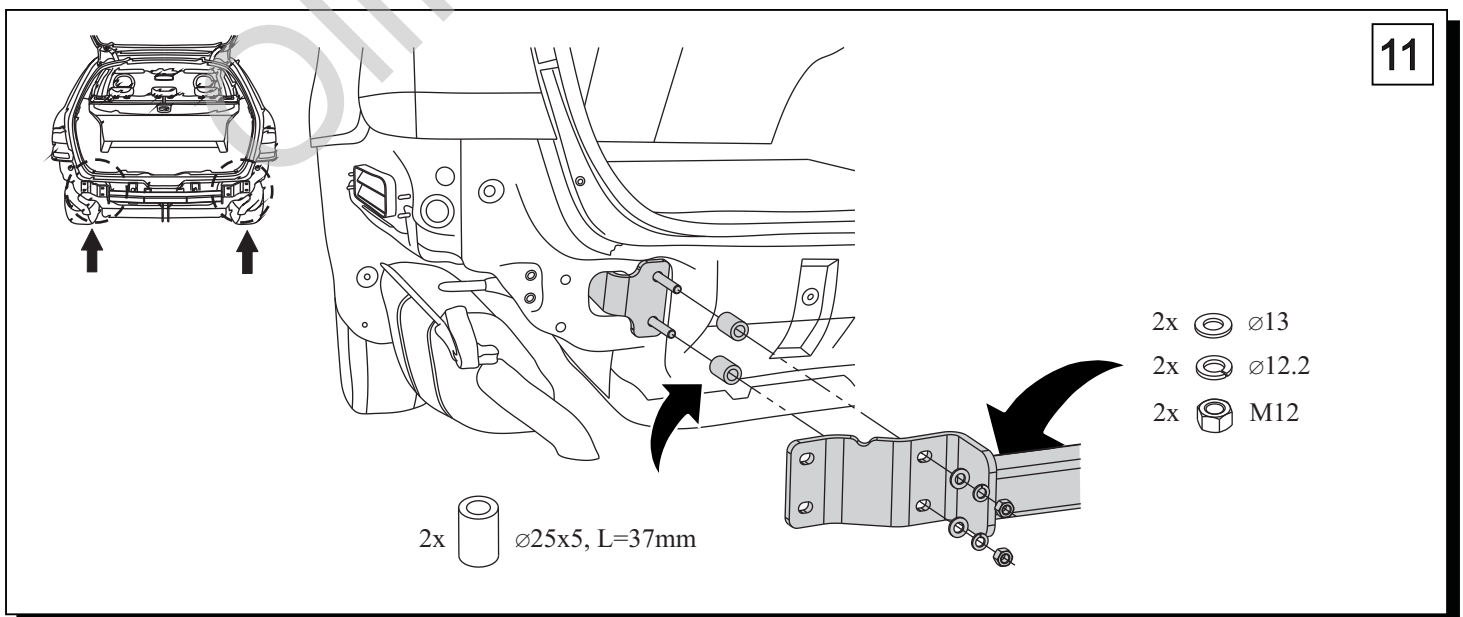
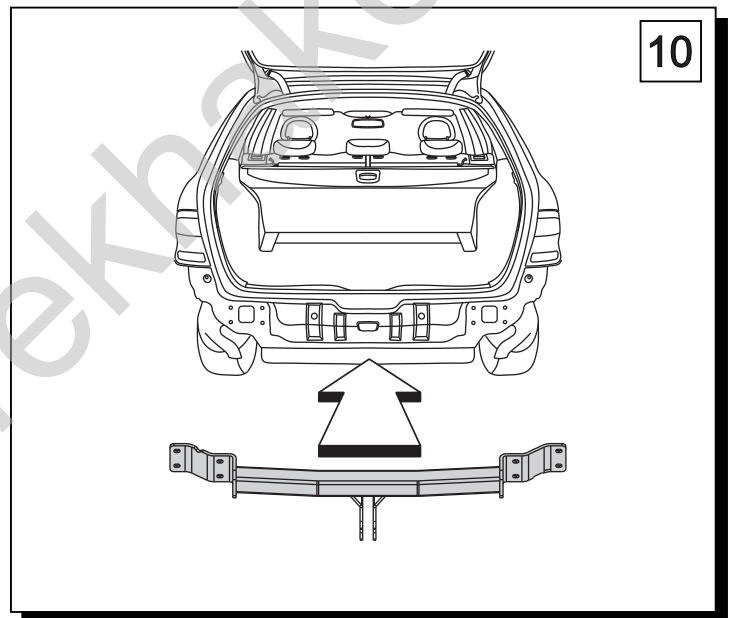
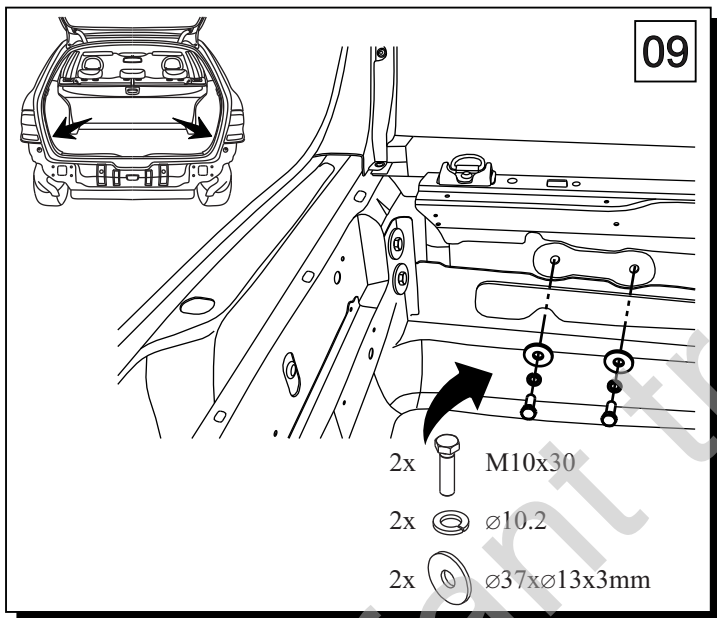
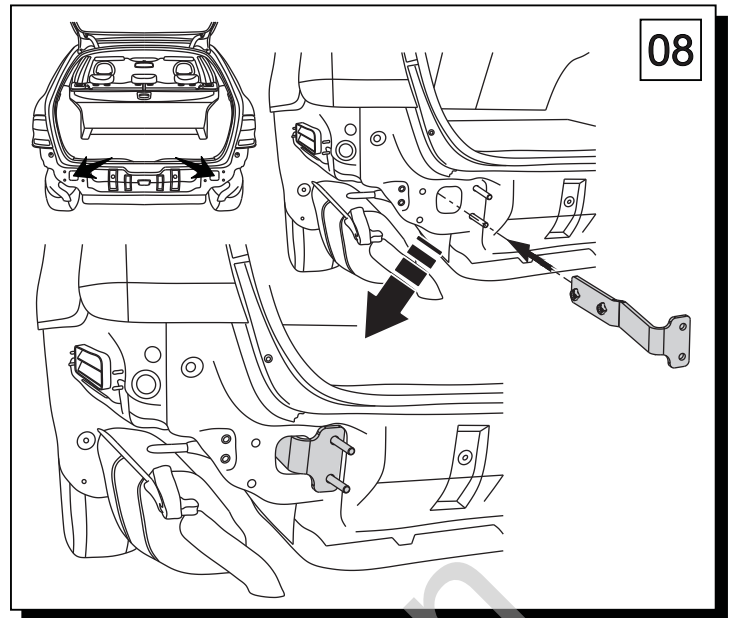
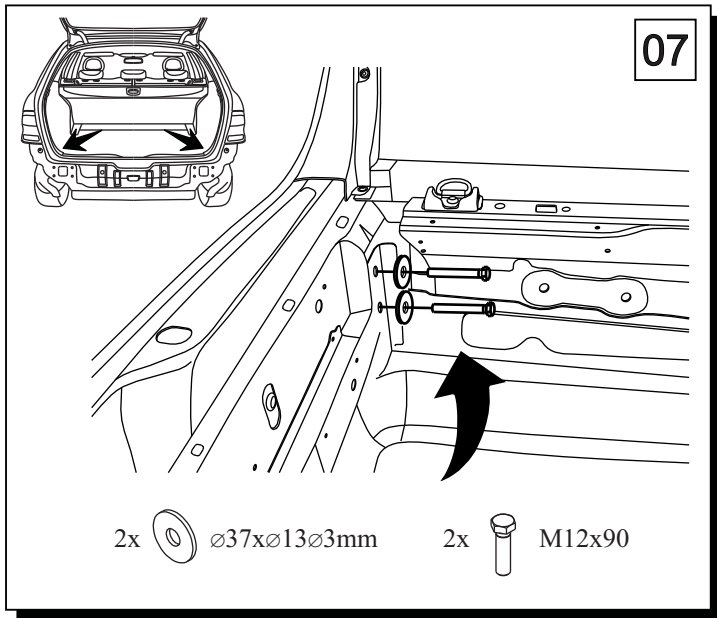

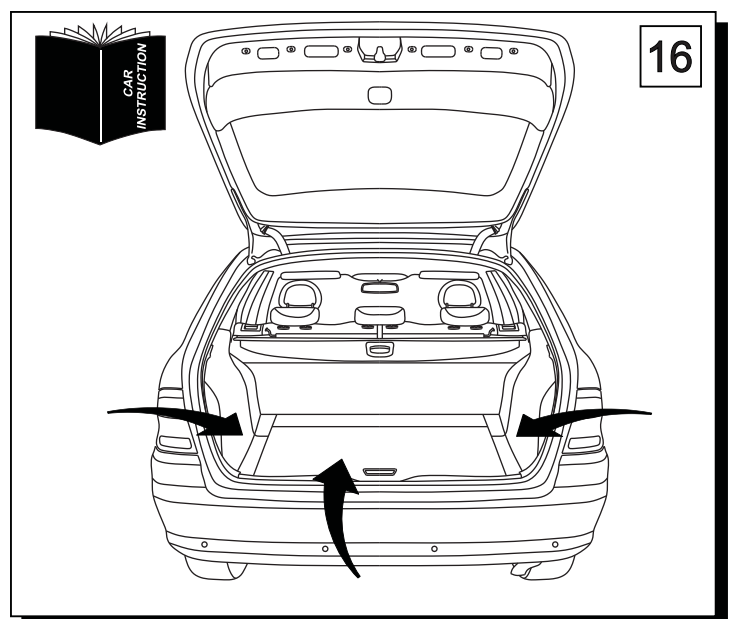
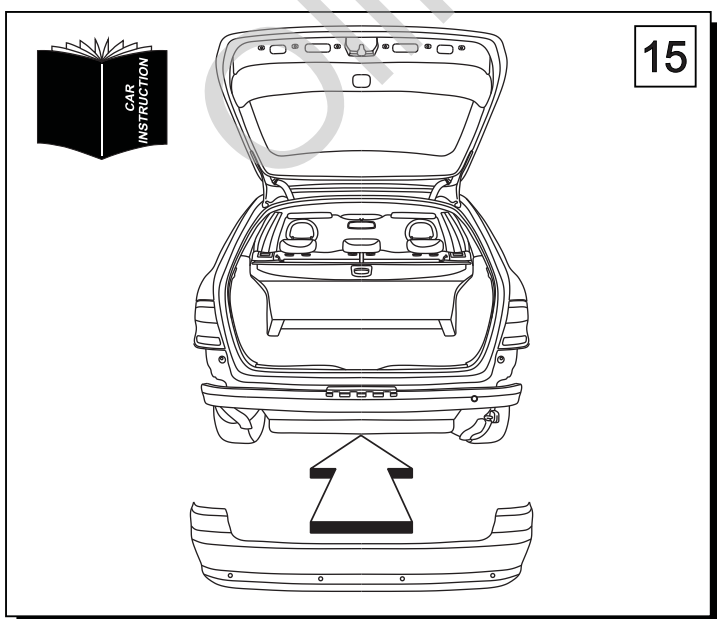
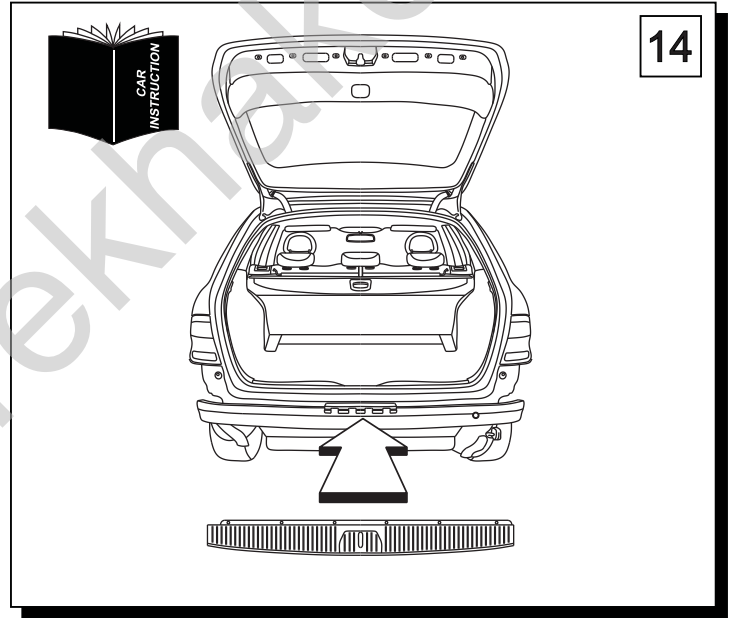
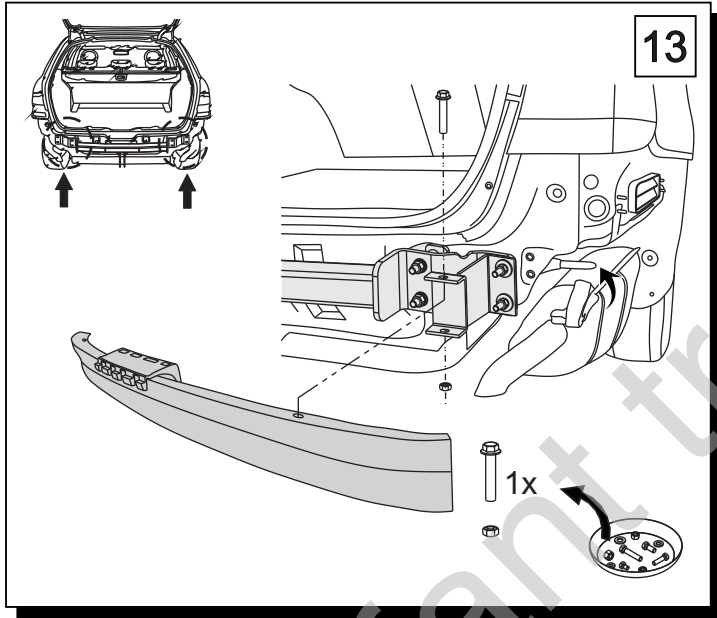
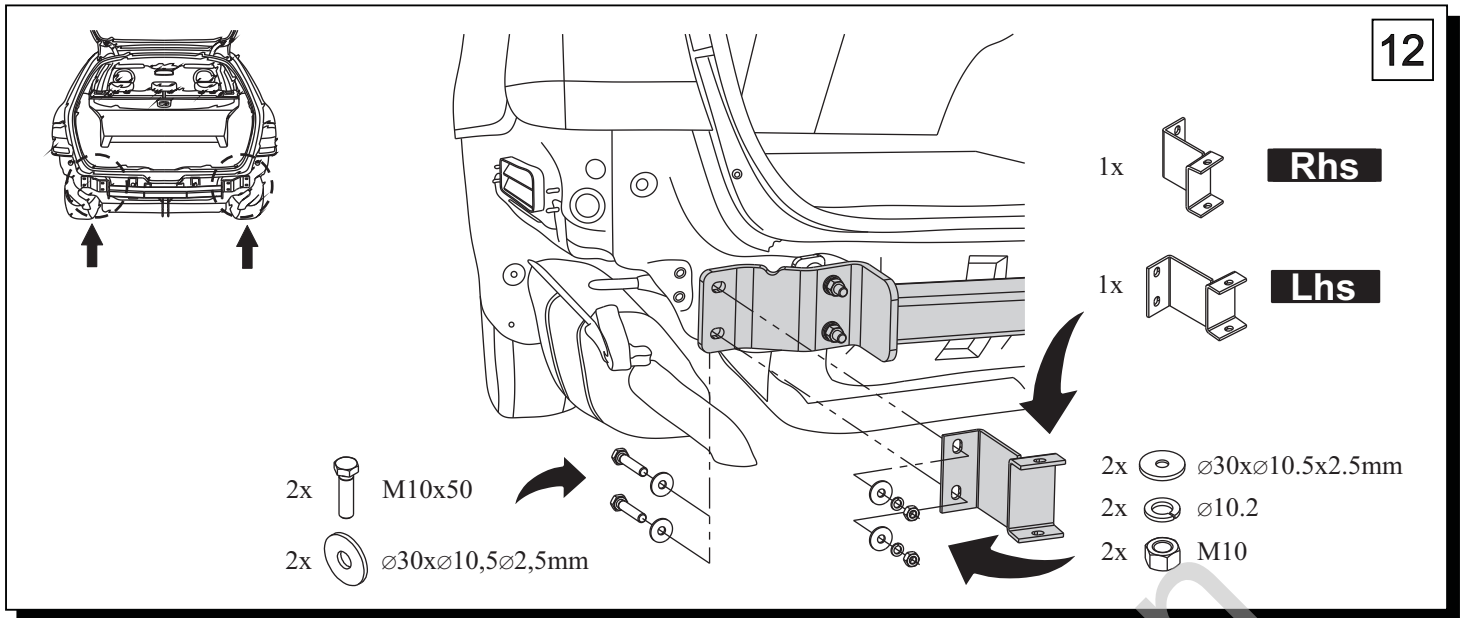



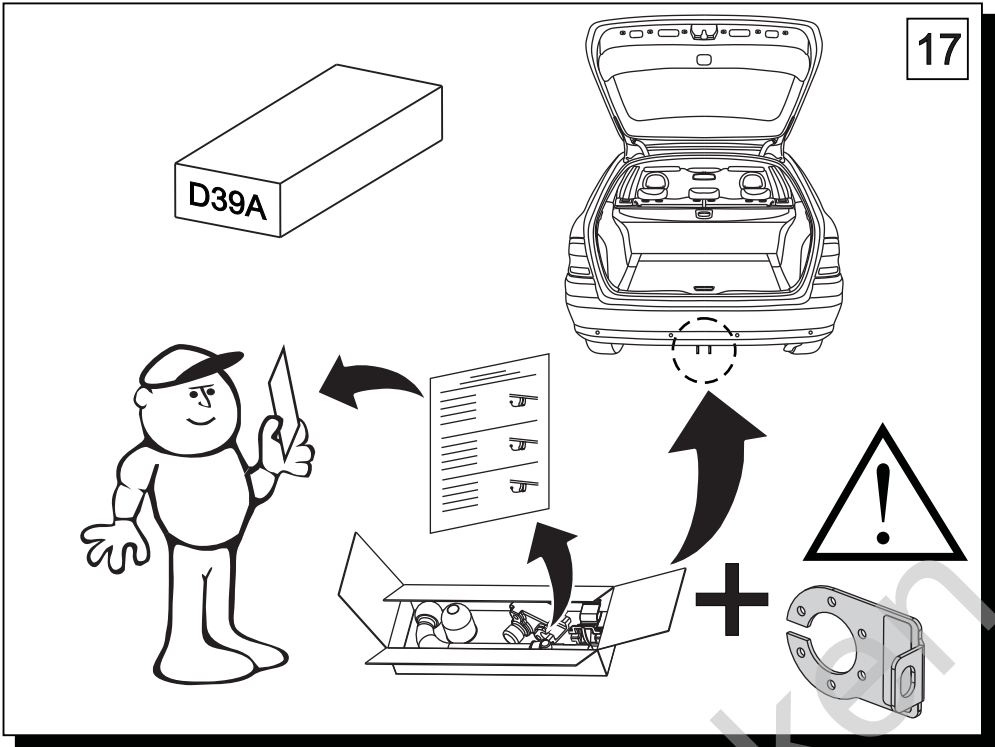

<b>M6</b>	-	11 Nm	<b>M8</b>	-	25 Nm
<b>M10</b>	-	50 Nm	<b>M12</b>	-	87 Nm
<b>M14</b>	-	138 Nm	<b>M16</b>	-	210 Nm

0 km → 1000 km