

## FITTING INSTRUCTION

Clamp mark in acc. with		Cables joining
ISO	PN	
1	L	Left directional lights
2	+	Rear fog lights
3	31	Ground
4	R	Right directional lights
5	58R	Right side parking lights
6	54	Stoplights
7	58L	Left side parking lights

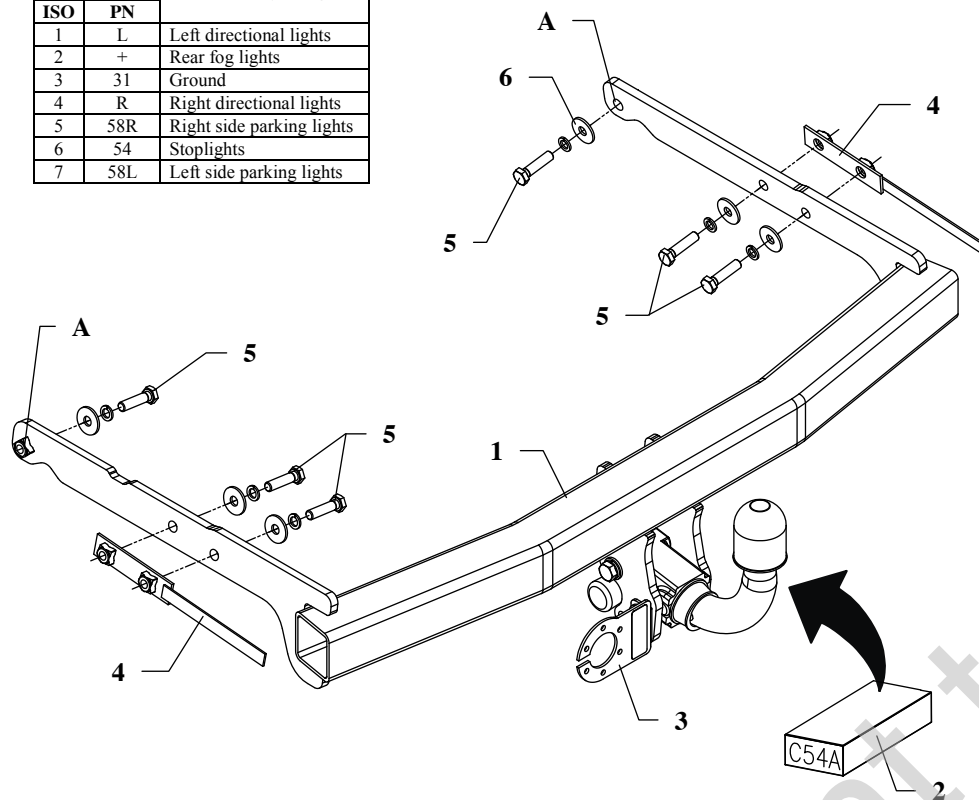

This towing hitch is designed to assembly in following car:  
**FORD MONDEO, 5 door (Mk4)**, produced since 05.2007 till 09.2014,  
 catalogue no. **C54A** and is prepared to tow trailers max total weight **2120 kg** and max vertical mass **80 kg**.

### *From manufacturer*

Thank you for buying our product. Their reliability has been confirmed in many tests. Reliability of towing hitch depends also on correct assembly and right operation. For this reasons we kindly ask to read carefully this instruction and apply to hints.

*The towing hitch should be install in points described by a car producer.*

## The instruction of the assembly

1. Disassemble bumper together with its metal reinforcement (reinforcement will be not reinstall). Reinstall bolts of reinforcement.
2. Take of a muffler from last handle and disassemble heatproof plate.
3. Slip in main bar of the towbar (pos. 1) to chassis member that way, so holes of main bar agree with holes prepared in chassis members. Fix loosely at points A by bolts M10x40mm (pos. 5).
4. Inside chassis members put nuts on the jib (pos. 4) and fix using bolts M10x40mm (pos. 5) as shown in the figure. Use big washers (pos. 6) – see figure.
5. Reassemble heatproof plate and hang up a muffler.
6. Fix body of the automat, the socket plate (pos. 3) and place tow-ball (pos. 2) according to supplied instruction.
7. Tighten all bolts according to the torque shown in the table.
8. Connect electric wires of 7-poles socket according to the instruction of the car. (Recommend to make at authorized service station).
9. Complete paint layer damaged during installation.

Torque settings for nuts and bolts (8,8):	
<b>M 8</b> - 25 Nm	<b>M 10</b> - 55 Nm
<b>M 12</b> - 85 Nm	<b>M 14</b> - 135 Nm





### NOTE

After install the towing hitch you should get adequate note in registration book (at authorised service station). The car should be equipped with:

- Indicators
- Tow mirrors

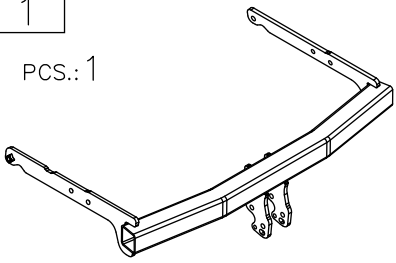
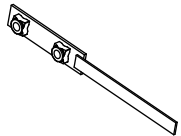
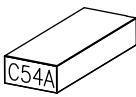
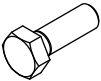
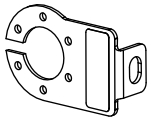
After 1000km of exploitation check all bolts and nuts. The ball of towing hitch must be always kept clear and conserve with a grease.

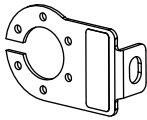
Towing hitch accessories:

Pos. 1	Main bar 	Pos. 4	Jib 
PCS.: 1		PCS.: 2	
Pos. 2	Tow ball 	Pos. 7	Bolt 8,8 B M10x40mm 
PCS.: 1		PCS.: 6	
Pos. 3	Socket plate 	Pos. 10	Washer ø30xø10.5x2.5mm 
PCS.: 1		PCS.: 6	
Pos. 3	Socket plate 	Pos. 12	Spring washer ø10mm 
PCS.: 1		PCS.: 6	



**PPUH AUTO-HAK S.J.**

Produkcja Zaczepów Kulowych  
Henryk i Zbigniew Nejman  
76-200 SŁUPSK ul. Słoneczna 16K  
tel/fax (059) 8-414-414; 8-414-413  
E-mail: [office@autohak.com.pl](mailto:office@autohak.com.pl)  
[www.autohak.com.pl](http://www.autohak.com.pl)

**Towing hitch (without electrical set)**

Class: **A50-X** Cat. no. **C54A**

Designed for:

Manufacturer: **FORD**

Model: **MONDEO**

Type: **5 door (Mk4)**

produced since 05.2007 till 09.2014

Technical data:

**D-value: 11,6 kN**

maximum trailer weight: **2120 kg**

maximum vertical cup mass: **80 kg**

**Approval number according to Directive 94/20/EC: e20\*94/20\*0736\*00**

**Foreword**

This towing hitch is designed according to rules of safety traffic regulations. The towing hitch is a safety component and can be install only by qualified personnel. Any alteration or conversion of the towing hitch is prohibited and would lead to cancellation of design certification. Remove insulating compound and underseal from vehicle (if present) in the area of the matting surfaces of the towing hitch. The vehicle manufacturer's specifications regarding trailer mass and max. vertical cup mass are decisive for driving whereat values for the towing hitch cannot be exceeded.

*D-value formula:*

$$\frac{\text{Max trailer weight [kg]} \times \text{Max vehicle weight [kg]}}{\text{Max trailer weight [kg]} + \text{Max vehicle weight [kg]}} \times \frac{9,81}{1000} = D \text{ [kN]}$$