

## FITTING INSTRUCTION

Clamp mark in acc. with		Cables joining
ISO	PN	
1	L	Left directional lights
2	+	Rear fog lights
3	31	Ground
4	R	Right directional lights
5	58R	Right side parking lights
6	54	Stoplights
7	58L	Left side parking lights

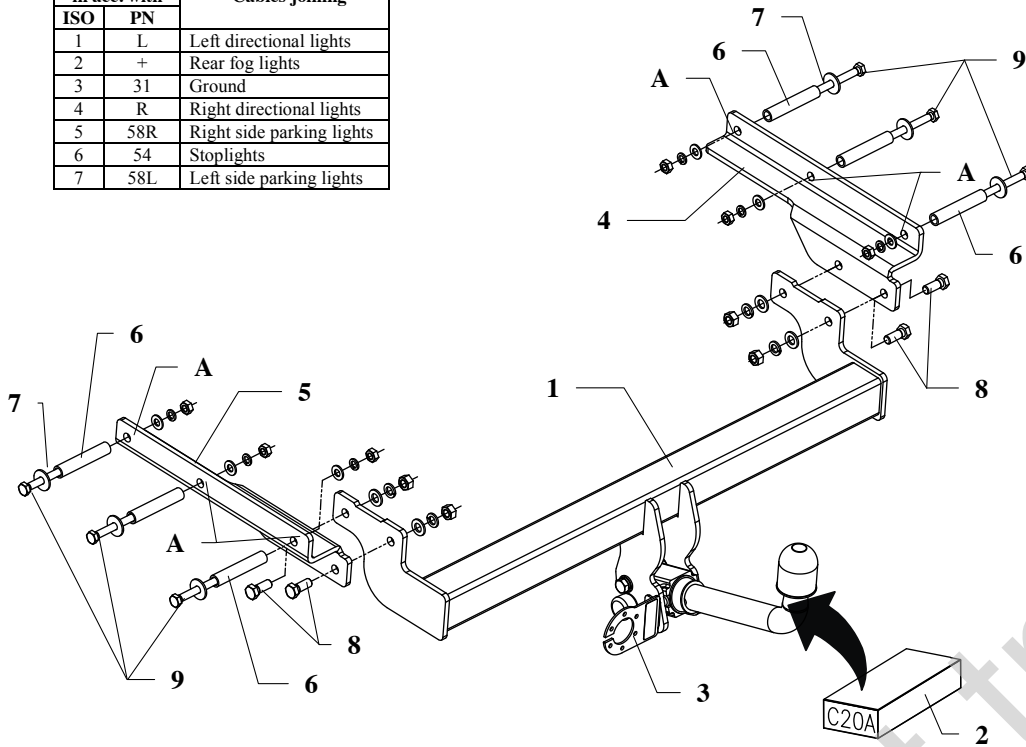

This towbar is designed to assembly in following car:  
**FORD MONDEO Turnier, ESTATE (Mk2), except ST 200 and RS**,  
 produced since 09. 1996 till 12.2000, catalogue no. **C20A** and is prepared to  
 tow trailers max total weight **1800 kg** and max vertical load **75 kg**.

### *From manufacturer*

Thank you for buying our product. Their reliability has been confirmed in many tests. Reliability of towbar depends also on correct assembly and right operation. For this reasons we kindly ask to read carefully this instruction and apply to hints.

*The towbar should be install in points described by a car producer.*

## The instruction of the assembly

1. On the left and right put distance sleeves L=94mm (pos. 6) to original holes in chassis members.
2. Put side brackets (pos. 4 and 5) and fix it to chassis members through holes (pos. A) and to installed sleeves using bolts M10x130mm (pos. 9) from the towbar accessories.
3. Put main bar of the towbar (pos. 1) and fix it to mounted side brackets (pos. 4 and 5) with M12x30mm bolts (pos. 8) from the towbar accessories.
4. Fix body of the automat and place tow-ball according to supplied instruction. Note! Remember to place socket plate (pos. 3) as shown on the drawing 1.
5. Fix tight all bolts according to the torque shown in the table.
6. Connect electric wires of 7-poles socket according to the instruction of the car. (Recommend to make at authorized service station)
7. Complete paint layer damaged during installation.

Torque settings for nuts and bolts (8,8):

<b>M6</b> - 11 Nm	<b>M8</b> - 25 Nm	<b>M10</b> - 50 Nm
<b>M12</b> - 87 Nm	<b>M14</b> - 138 Nm	<b>M16</b> - 210 Nm

### NOTE

After mounting the towbar you should sign the car card at the Authorised Car Station.

The car should be equipment with:

- Indicators
- Tow mirrors

After 1000 km of exploitation check mounting bolts. The ball of towbar has to be kept in clear and conserve with a grease.

## Towbar accessories:

Pos. 1	Name: Main bar Quantity: 1	Pos. 6	Name: Distance sleeve Quantity: 6 Dim.: $\varnothing 17.2 \times 2.35 \text{ mm}$	Pos. 12	Name: Spring washer Quantity: 4 Dim.: $\varnothing 12,2 \text{ mm}$
Pos. 2	Name: Tow ball Quantity: 1	Pos. 7	Name: Washer Quantity: 6 Dim.: $\varnothing 30 \times \varnothing 10,5 \times 2,5 \text{ mm}$	Pos. 13	Name: Spring washer Quantity: 6 Dim.: $\varnothing 10,2 \text{ mm}$
		Pos. 8	Name: Bolt 8,8 B Quantity: 4 Dim.: M12x30mm	Pos. 14	Name: Nut 8 B Quantity: 4 Dim.: M12
Pos. 3	Name: Socket plate Quantity: 1	Pos. 9	Name: Bolt 8,8 B Quantity: 6 Dim.: M10x130mm	Pos. 16	Name: Nut 8 B Quantity: 6 Dim.: M10
Pos. 4	Name: Right bracket Quantity: 1	Pos. 10	Name: Plain washer Quantity: 4 Dim.: $\varnothing 13 \text{ mm}$		
Pos. 5	Name: Left bracket Quantity: 1	Pos. 11	Name: Plain washer Quantity: 6 Dim.: $\varnothing 10,5 \text{ mm}$		



**PPUH AUTO-HAK S. J.**

Produkcja Zaczepów Kulowych  
Henryk i Zbigniew Nejman  
76-200 SŁUPSK ul. Słoneczna 16K  
tel/fax (059) 8-414-414; 8-414-413  
E-mail: [office@autohak.com.pl](mailto:office@autohak.com.pl)  
[www.autohak.com.pl](http://www.autohak.com.pl)

## Towing hitch (without electrical set)

Class: **A50-X** Cat. no. **C20A**

Designed for:

Manufacturer: **FORD**

Model: **MONDEO Turnier**

Type: **ESTATE (Mk2), except ST 200 and RS**  
produced since 09.1996 till 12.2000

Technical data:

**D-value: 9,18 kN**

maximum trailer weight: **1800 kg**

maximum vertical cup load: **75 kg**

**Approval number according to Directive 94/20/EC: e20\*94/20\*0973\*00**

## Foreword

This towbar is designed according to rules of safety traffic regulations. The towing hitch is a safety component and must be installed only by qualified personnel. Any alteration or conversion to the towinh hitch is prohibited and would lead to cancellation of design certification. Remove insulating compound and underseal from vehicle (if present) in the area of the matting surfaces of the towing hitch.

The vehicle manufacturer's specifications regarding trailer load and max. vertical cup load are decisive for driving, and values for the towing hitch cannot be exceeded.

*D-value formula:*

$$\frac{\text{Max trailer weight [kg]} \times \text{Max vehicle weight [kg]}}{\text{Max trailer weight [kg]} + \text{Max vehicle weight [kg]}} \times \frac{9,81}{1000} = D \text{ [kN]}$$