

FITTING INSTRUCTION

Clamp mark in acc. with		Cables joining
ISO	PN	
1	L	Left directional lights
2	+	Rear fog lights
3	31	Ground
4	R	Right directional lights
5	58R	Right side parking lights
6	54	Stoplights
7	58L	Left side parking lights

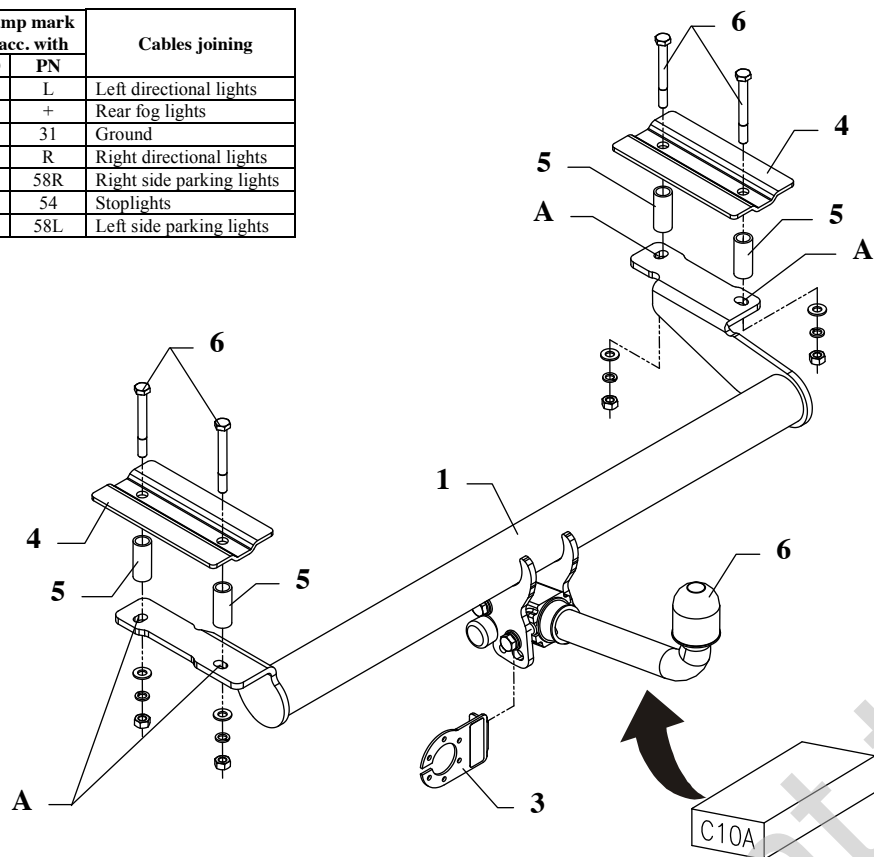

This towing hitch is designed to assembly in following cars:
FORD ESCORT, 3/5 doors, Cabrio, except 4x4, produced since 01.1996 till 10.1998, catalogue no. **C10A** and is prepared to tow trailers max total weight **1250 kg** and max vertical mass **50 kg**.

From manufacturer

Thank you for buying our product. Their reliability has been confirmed in many tests. Reliability of towing hitch depends also on correct assembly and right operation. For this reasons we kindly ask to read carefully this instruction and apply to hints.

The towing hitch should be install in points described by a car producer.

Fitting instructions

1. It is not necessary to reassemble the bumper.
2. Find original signed places inside the boot on the left and right side, then drill $\varnothing 24\text{mm}$.
3. Slide the sleeves $L=50\text{mm}$ (pos. 5) and position the element (pos. 4).
4. Position the main bar of towing hitch (pos. 1) and fix it through the holes (pos. A), sleeves (pos. 5) and the elements (pos. 4) using $M10 \times 90\text{mm}$ (pos. 6).
5. Tighten all nuts and bolts according to the torque shown in the table.
6. Fix body of the automat and place tow-ball according to supplied instruction. Note! Remember to place socket plate (pos. 3) as shown on the drawing 1.
7. Connect the electric wires according to the instructions of the car.
8. Complete the paint cover of towing hitch (during the mounting paint cover could be destroyed).

Torque settings for nuts and bolts (8,8):	
M 8 - 25 Nm	M 10 - 55 Nm
M 12 - 85 Nm	M 14 - 135 Nm





NOTE

After install the towing hitch you should get adequate note in registration book (at authorised service station).The car should be equipped with:

- Indicators
- Tow mirrors

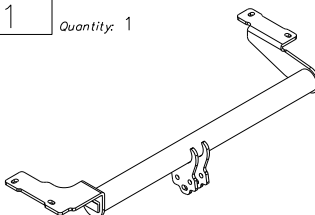
After 1000km of exploitation check all bolts and nuts. The ball of towing hitch must be always kept clear and conserve with a grease.

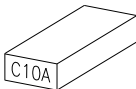
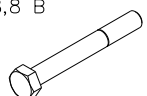
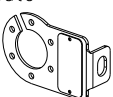
Towing hitch accessories:

Pos. 1	Name: Main bar Quantity: 1	Pos. 4	Name: Fish-plate of bracket Quantity: 2 Dim.: 200x100x5mm	Pos. 8	Name: Plain washer Quantity: 4 Dim.: ϕ 10,5 mm
		Pos. 5	Name: Distance sleeve Quantity: 4 Dim.: ϕ 21,3x2,35 L=50mm	Pos. 9	Name: Spring washer Quantity: 4 Dim.: ϕ 10,2 mm
					
Pos. 2	Name: Tow ball Quantity: 1	Pos. 6	Name: Bolt 8,8 B Quantity: 4 Dim.: M10x90mm		
					
Pos. 3	Name: Socket plate Quantity: 1	Pos. 7	Name: Nut 8 B Quantity: 4 Dim.: M10		
					



PPUH AUTO-HAK S. J.

Produkcja Zaczepów Kulowych
Henryk i Zbigniew Nejman
76-200 SŁUPSK ul. Słoneczna 16K
tel/fax (059) 8-414-414; 8-414-413
E-mail: office@autohak.com.pl
www.autohak.com.pl

Towing hitch (without electrical set)

Class: **A50-X** Cat. no. **C10A**

Designed for:

Manufacturer: **FORD**

Model: **ESCORT**

Type: **3/5 doors, Cabrio, except 4x4**

produced since 01.1996 till 10.1998

Technical data:

D-value: 6,88 kN

maximum trailer weight: **1250 kg**

maximum vertical cup mass: **50 kg**

Approval number according to Directive 94/20/EC: e20*94/20*0893*00

Foreword

This towing hitch is designed according to rules of safety traffic regulations. The towing hitch is a safety component and can be install only by qualified personnel. Any alteration or conversion of the towing hitch is prohibited and would lead to cancellation of design certification. Remove insulating compound and underseal from vehicle (if present) in the area of the matting surfaces of the towing hitch.

The vehicle manufacturer's specifications regarding trailer load and max. vertical cup load are decisive for driving, and values for the towing hitch cannot be exceeded.

D-value formula:

$$\frac{\text{Max trailer weight [kg]} \times \text{Max vehicle weight [kg]}}{\text{Max trailer weight [kg]} + \text{Max vehicle weight [kg]}} \times \frac{9,81}{1000} = D \text{ [kN]}$$