

FITTING INSTRUCTION

Clamp mark in acc. with		Cables joining
ISO	PN	
1	L	Left directional lights
2	+	Rear fog lights
3	31	Ground
4	R	Right directional lights
5	58R	Right side parking lights
6	54	Stoplights
7	58L	Left side parking lights

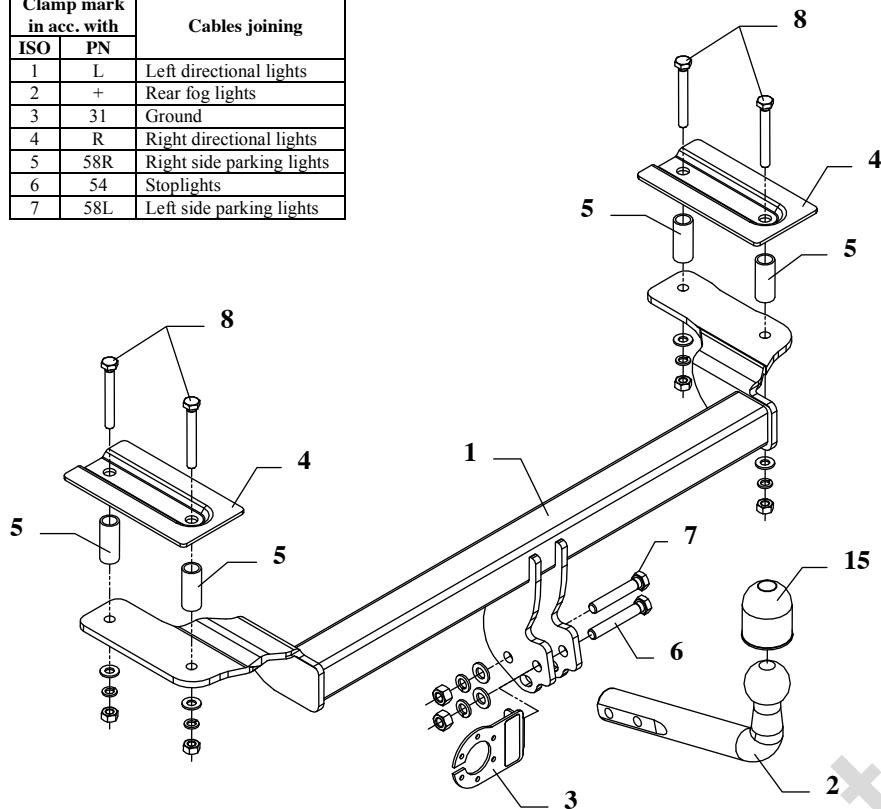

This towbar is designed to assembly in following cars:
FORD FIESTA, 3/5 doors, except Sport, produced since 01.1996 till 04.2002 and **MAZDA 121, 3/5 doors (JASM/JBSM)**, produced since 03.1996 till 08.1999, catalogue no. **C002** and is prepared to tow trailers max total weight **950 kg** and max vertical load **50 kg**.

From manufacturer

Thank you for buying our product. Their reliability has been confirmed in many tests. Reliability of towbar depends also on correct assembly and right operation. For this reasons we kindly ask to read carefully this instruction and apply to hints.

The towbar should be install in points described by a car producer.

The instruction of the assembly

1. Take the spare wheel out the bumper.
2. Find original metal covers on the left and right sight (inside the trunk), remove it, then you will see holes towards the chassis members.
3. Put the distance sleeves L=50mm (pos. 5) there and position the fish-plates (pos. 4) and bolts M10x80mm (pos. 8) - see the fig.
4. Position the main bar of the towbar (pos. 1) at the bottom of the car and then fix it.
5. Position the ball of towbar (pos. 2) with socket plate (pos. 3) and fix with bolts M12x75mm (pos. 6) and M12x70mm (pos. 7) from the towbar accessories.
6. Tighten all nuts and bolts according to the torque shown in the table.
7. Connect to the electric wires according to the instructions of the car.
8. Complete the paint cover of towbar (during the mounting paint cover could be destroyed).

Torque settings for nuts and bolts (8,8):

M6 - 11 Nm	M8 - 25 Nm	M10 - 50 Nm
M12 - 87 Nm	M14 - 138 Nm	M16 - 210 Nm

NOTE









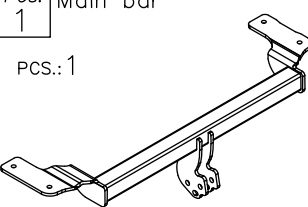

After install the towbar you should get adequate note in registration book (at authorised service station).The car should be equipped with:

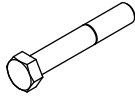
- Indicators
- Tow mirrors

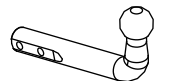
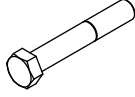
After 1000km of exploitation check all bolts and nuts. The ball of towbar must be always kept clear and conserve with a grease.

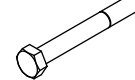

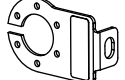
Towbar accessories:

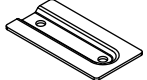
Pos. 1 Main bar PCS.: 1 	Pos. 5 Distance sleeve ø21,3x2,35mm L=50mm PCS.: 4 	Pos. 10 Plain washer ø10,5mm PCS.: 4 
	Pos. 6 Bolt 8,8 B M12x75mm PCS.: 1 	Pos. 11 Spring washer ø12,2mm PCS.: 2 
Pos. 2 Tow ball PCS.: 1 	Pos. 7 Bolt 8,8 B M12x70mm PCS.: 1 	Pos. 12 Spring washer ø10,2mm PCS.: 4 
	Pos. 8 Bolt 8,8 B M10x80mm PCS.: 4 	Pos. 13 Nut 8 B M12 PCS.: 2 
Pos. 3 Socket plate PCS.: 1 	Pos. 9 Plain washer ø13mm PCS.: 2 	Pos. 14 Nut 8 B M10 PCS.: 4 
		Pos. 4 Fish-plate PCS.: 2 

Towing hitch (without electrical set)

Class: **A50-X** Cat. no. **C002**

Designed for:
Manufacturer: **FORD**
Model: **FIESTA**
Type: **3/5 doors, except Sport**
produced since 01.1996 till 04.2002
Manufacturer: **MAZDA**
Model: **121**
Type: **3/5 doors (JASM/JBSM)**
produced since 03.1996 till 08.1999

Technical data:
D-value: 5,75 kN
maximum trailer weight: **950 kg**
maximum vertical cup load: **50 kg**

Approval number acc. to regulations EKG/ONZ 55.01: E20-55R-01 0880

Foreword

This towbar is designed according to rules of safety traffic regulations. The towing hitch is a safety component and can be install only by qualified personnel. Any alteration or conversion of the towing hitch is prohibited and would lead to cancellation of design certification. Remove insulating compound and underseal from vehicle (if present) in the area of the matting surfaces of the towing hitch.

The vehicle manufacturer's specifications regarding trailer load and max. vertical cup load are decisive for driving whereat values for the towing hitch cannot be exceeded.

D-value formula:

$$\frac{\text{Max trailer weight [kg]} \times \text{Max vehicle weight [kg]}}{\text{Max trailer weight [kg]} + \text{Max vehicle weight [kg]}} \times \frac{9,81}{1000} = D \text{ [kN]}$$