

# PPUH AUTO-HAK Sp.J.

Henryk & Zbigniew Nejman  
ul. Słoneczna 16K 76-200 SŁUPSK  
POLAND

tel/fax +48 059 8-414-414; 8-414-413

e-mail: [office@autohak.com.pl](mailto:office@autohak.com.pl)

[www.autohak.com.pl](http://www.autohak.com.pl)



# AUTO-HAK



**TOYOTA CAMRY**  
4D, (V30)

Cat. no:

**063**



11.2001 → 12.2005

e20

e20\*94/20\*0305\*00



**1,5h**

**D**

9,5 kN



R=1700 kg





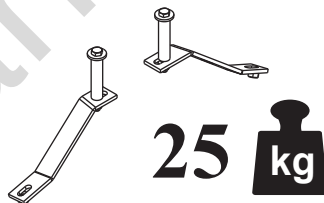



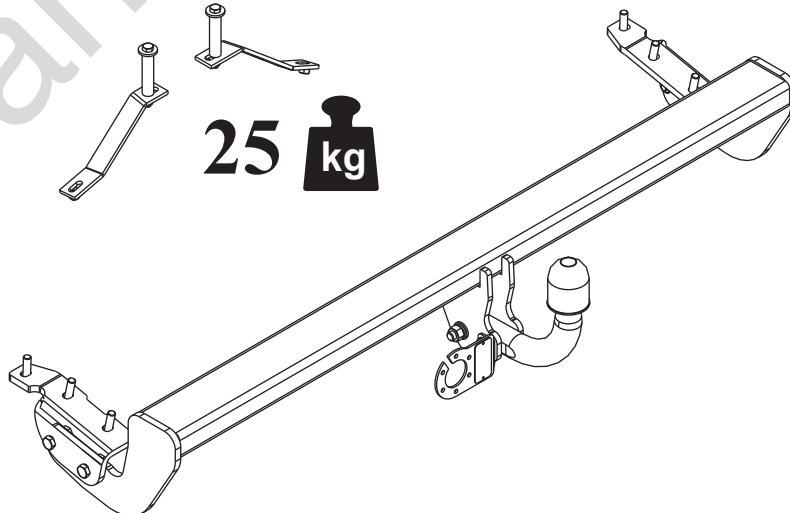

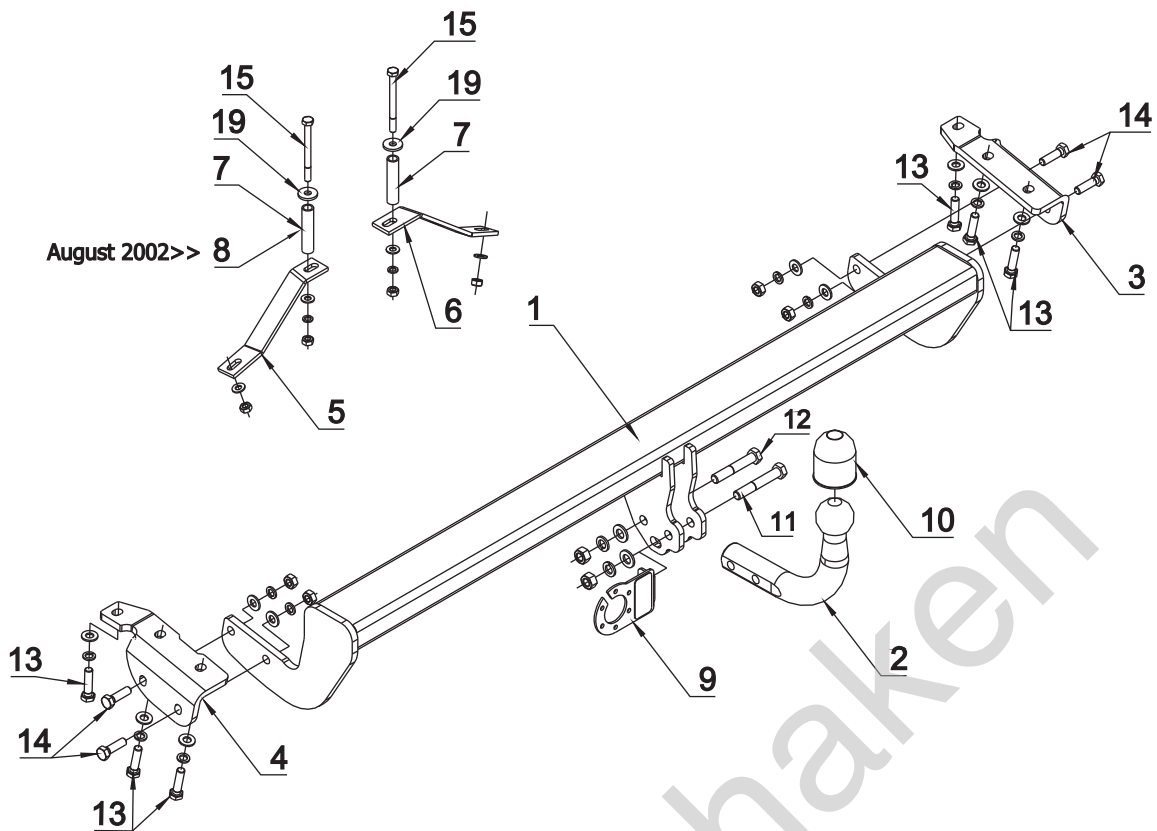

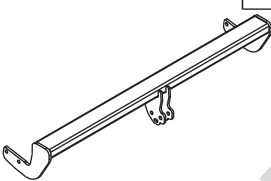

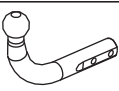

S=75 kg



**25 kg**





1		x1		11 M12x75	x1
2		x1 Art.nr-KL1063		12 M12x70	x1
3		x1		13 M10x1,25x40	x6
4		x1	14 M10x35	x4	
5		x1	15 M8x90	x2	
6		x1		16 $\phi$ 13	x2
7		x2		17 $\phi$ 10.5	x10
8	August 2002>> 	x1		18 $\phi$ 8.5	x4
9		x1 Art.nr-BL1063		19 $\phi$ 24x $\phi$ 8.5x2 8 (DIN 9021)	x2
10		x1		20 $\phi$ 12.2	x2
				21 $\phi$ 10.2	x10
				22 $\phi$ 8.2	x2
			23 M12	x2	
			24 M10	x4	
			25 M8	x4	

