

## FITTING INSTRUCTION

Clamp mark in acc. with		Cables joining
ISO	PN	
1	L	Left directional lights
2	+	Rear fog lights
3	31	Ground
4	R	Right directional lights
5	58R	Right side parking lights
6	54	Stoplights
7	58L	Left side parking lights

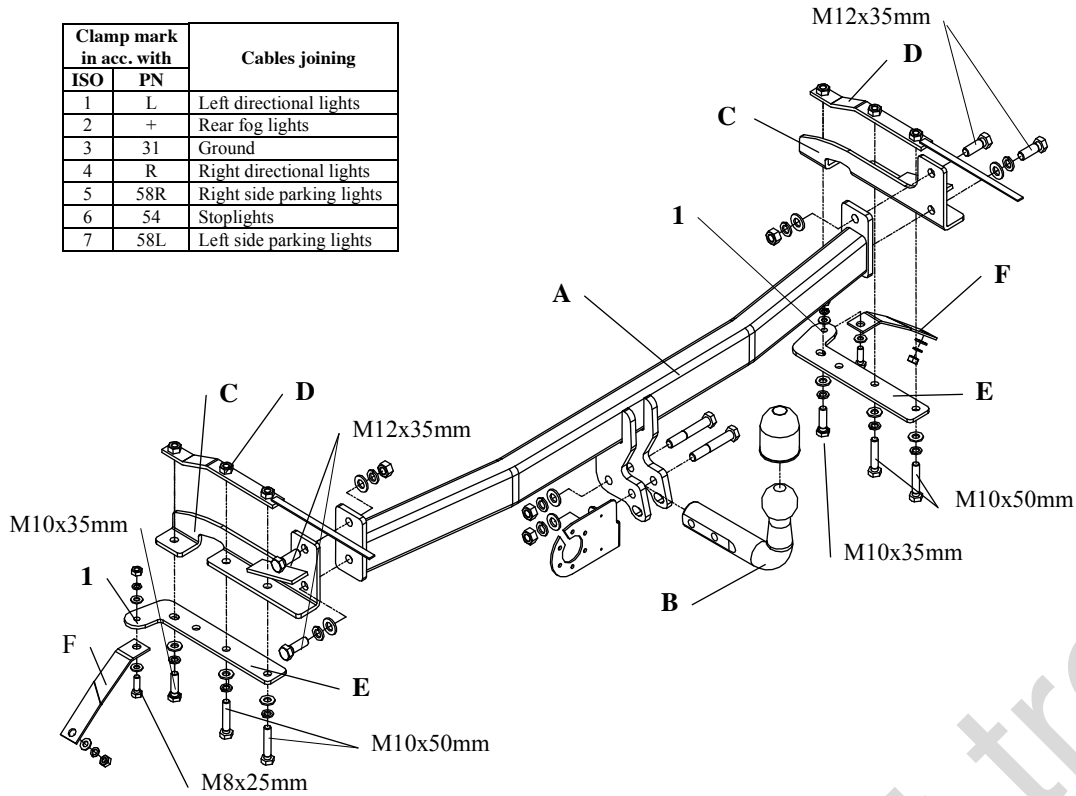

This towbar is designed to assembly in following car:  
**TOYOTA COROLLA 4 door, (E12)**, produced since 07.2002 till 02.2007, catalogue number **O48** and is prepared to tow trailers max total weight **1300 kg** and max vertical load **75 kg**.

### *From manufacturer*

Thank you for buying our product. Their reliability has been confirmed in many tests. Reliability of towbar depends also on correct assembly and right operation. For this reasons we kindly ask to read carefully this instruction and apply to hints.

*The towbar should be install in points described by a car producer.*

## The instruction of the assembly

1. Disassemble a bumper.
2. Disassemble a reinforcement of bumper (not used any more).
3. Unscrew original tow handles.
4. Disassemble a muffler and a thermal sheet.
5. Slide elements (pos. C) and (pos. D) to chassis members and screw with elements pos. E (element E put from below chassis member). (**Note: Screw together with tow handles (see drawing).**)
6. Between elements (pos. C) put bar of towbar (pos. A) and screw with bolts M12x35mm from equipment.
7. Element (pos. F) screw in point pos. 1 and with body (see drawing).
8. Assemble the bumper after cut off his fragment (see fig. 2).
9. Screw spherical element (pos. B) and socket plate using bolts M12x75mm from equipment.
10. Assemble a thermal sheet and a muffler.
11. Tighten all bolts according to the torque shown in the table.
12. Connect electric wires of 7-poles socket according to the instruction of the car. (Recommend to make at authorized service station).
13. Complete paint layer damaged during installation.

Fig. 2

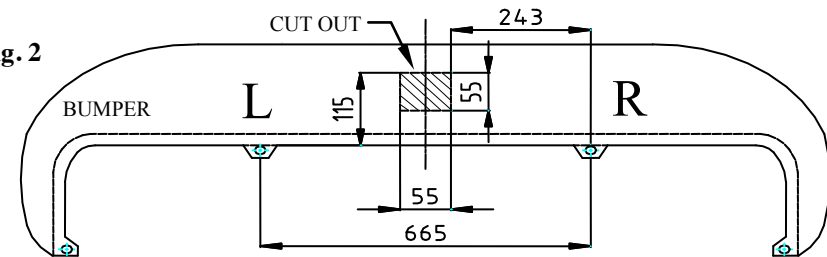

Torque settings for nuts and bolts 8,8 :

<b>M 8</b>	25 Nm	<b>M 10</b>	55 Nm
<b>M 12</b>	85 Nm	<b>M 14</b>	135 Nm

### NOTE

After install the towbar you should get adequate note in registration book (at authorised service station). The car should be equipped with:

- Indicators
- Tow mirrors

After 1000km of exploitation check all bolts and nuts. The ball of towbar must be always kept clear and conserve with a grease.



## PPUH AUTO-HAK S.J.

Produkcja Zaczepów Kulowych  
Henryk & Zbigniew Nejman  
76-200 SŁUPSK ul. Słoneczna 16K  
tel/fax (059) 8-414-414; 8-414-413  
E-mail: office@autohak.com.pl  
www. autohak.com.pl

### Towing hitch (without electrical set)

Class: **A50-X** Cat. no. **O48**

Designed for:

Manufacturer: **TOYOTA**

Model: **COROLLA**

Type: **4 door (E12)**

produced since 07.2002 till 02.2007

Technical data:

**D-value: 7,35 kN**

maximum trailer weight: **1300 kg**

maximum vertical cup load: **75 kg**

**Approval number acc. to regulations EKG/ONZ 55.01: E20-55R-01 1033**

### *Foreword*

This towbar is designed according to rules of safety traffic regulations. The towing hitch is a safety component and can be install only by qualified personnel. Any alteration or conversion of the towing hitch is prohibited and would lead to cancellation of design certification. Remove insulating compound and underseal from vehicle (if present) in the area of the matting surfaces of the towing hitch.

The vehicle manufacturer's specifications regarding trailer load and max. vertical cup load are decisive for driving whereat values for the towing hitch cannot be exceeded.

*D-value formula:*

$$\frac{\text{Max trailer weight [kg]} \times \text{Max vehicle weight [kg]}}{\text{Max trailer weight [kg]} + \text{Max vehicle weight [kg]}} \times \frac{9,81}{1000} = D \text{ [kN]}$$