

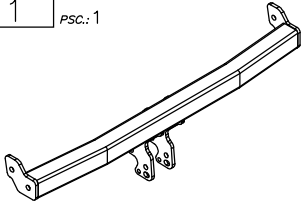

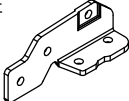





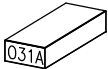

## Towbar accessories:

Pos. 1	Main bar PSC.: 1	Pos. 5	Right bracket PSC.: 1	Pos. 10	Plain washer PSC.: 8 Ø 13 mm
					
		Pos. 6	Bolt 8,8 B PSC.: 8 M12x35mm	Pos. 11	Plain washer PSC.: 2 Ø 10,5 mm
					
Poz. 2	Tow ball (mounting set) PCS.:1	Pos. 7	Bolt 8,8 B PSC.: 2 M10x35mm	Pos. 12	Spring washer PSC.: 8 Ø 12,2 mm
					
Pos. 3	Socket plate PSC.: 1	Pos. 8	Nut 8 B PSC.: 8 M12	Pos. 13	Spring washer PSC.: 2 Ø 10,2 mm
					
Pos. 4	Left bracket PSC.: 1	Pos. 9	Nut 8 B PSC.: 2 M10		
					

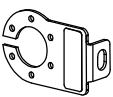

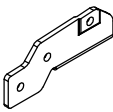
**PPUH AUTO-HAK S.J.**

Produkcja Haków Holowniczych  
Henryk & Zbigniew Nejman  
76-200 SŁUPSK ul. Słoneczna 16K  
tel/fax (059) 8-414-414; 8-414-413  
e-mail: [office@autohak.com.pl](mailto:office@autohak.com.pl)  
[www.autohak.com.pl](http://www.autohak.com.pl)

## Towing hitch (without electrical set)

Class: **A50-X** Cat. no. **O 31A**

Designed for:

Manufacturer: **TOYOTA**

Model: **COROLLA**

Type: **Station Wagon, ESTATE, (E10)**

produced since 08.1992 till 05.1997

Technical data:

**D-value: 7,6 kN**

maximum trailer weight: **1300 kg**

maximum vertical cup load: **75 kg**

Approval number acc. to regulations EKG/ONZ 55.01: **E20-55R-01 1517**

## Foreword

This towbar is design according to rules of safety traffic regulations. The towing hitch is a safety component and must be installed only by qualified personnel. Any alteration or conversion to the towinh hitch is prohibited and would lead to cancellation of design certification. Remove insulating compound and underseal from vehicle (if present) in the area of the matting surfaces of the towing hitch. The vehicle manufacturer's specifications regarding trailer load and max. vertical cup load are decisive for driving, and values for the towing hitch must not be exceeded.

*D-value formula:*

$$\frac{\text{Max trailer weight [kg]} \times \text{Max vehicle weight [kg]}}{\text{Max trailer weight [kg]} + \text{Max vehicle weight [kg]}} \times \frac{9,81}{1000} = D \text{ [kN]}$$

## FITTING INSTRUKCION

Clamp mark in acc. with		Cables joining
ISO	PN	
1	L	Left directional lights
2	+	Rear fog lights
3	31	Ground
4	R	Right directional lights
5	58R	Right side parking lights
6	54	Stoplights
7	58L	Left side parking lights

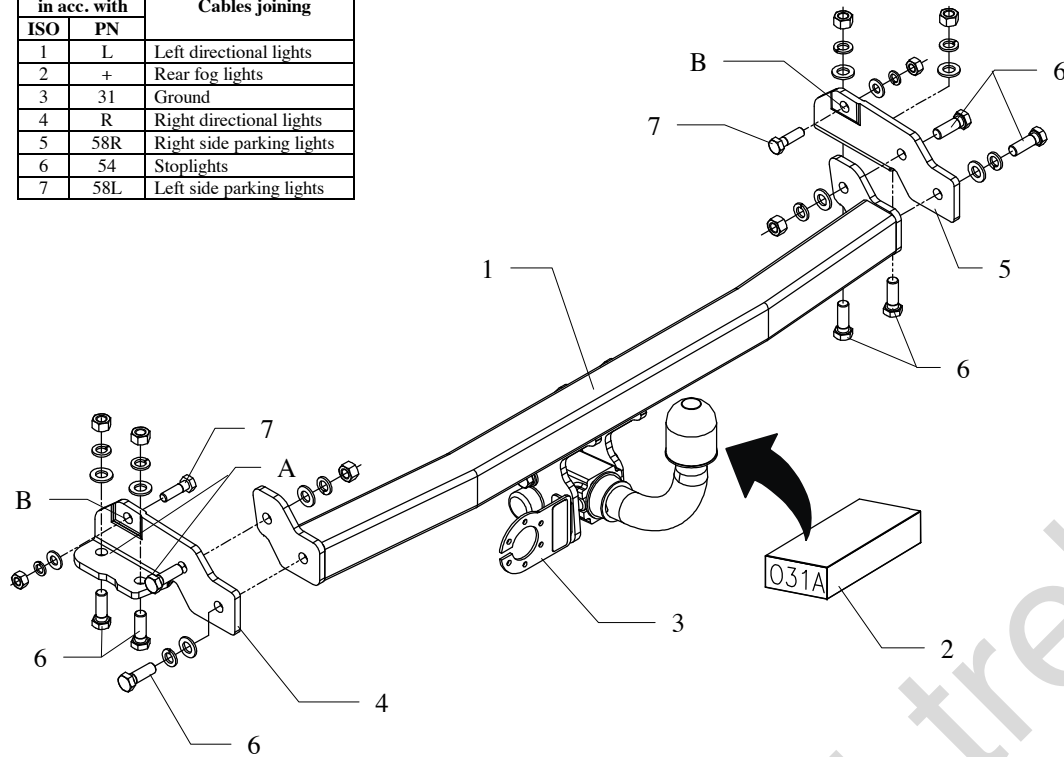

This towbar is designed to assembly in following cars:  
**TOYOTA COROLLA, Station Wagon, ESTATE, (E10)**, produced since 08.1992 till 05.1997, catalogue no. **O31A** and is prepared to tow trailers max total weight **1300 kg** and max vertical load **75 kg**.

### From manufacturer

Thank you for buying our product. Their reliability has been confirmed in many tests. Reliability of towbar depends also on correct assembly and right operation. For this reasons we kindly ask to read carefully this instruction and apply to hints.

*The towbar should be install in points described by a car producer.*

Fig. 2 Bumper's cut out.

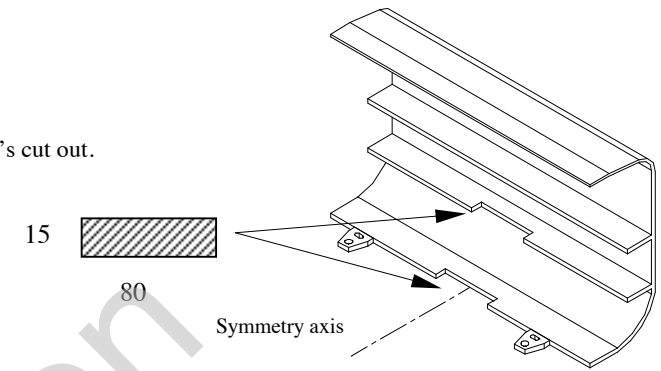

### Fitting instructions

1. Disassemble the rear bumper.
2. Disassemble original tow handles ( not used any more).
3. To the left chassis member put element pos. 4, to the right chassis member put element pos. 5. Next fix using bolts M12x35mm (pos. 6) through holes A and using bolts M10x35mm (pos. 7) through holes B (loosely).
4. Between mounted brackets (pos. 4 and 5) slip body of the towbar pos. 1 and fix it by bolts M12x35mm (pos. 6) from accessories.
5. Tighten all bolts according to the torque shown in the table.
6. Reassemble the bumper after cut fragments – see figure 2.
7. Fix body of the automat and place tow-ball according to supplied instruction. Note! Remember to place socket plate (pos. 3) as shown on the drawing 1.
8. Connect electric wires of 7-pole socket according to the instruction of the car. (Recommend to make at authorized service station)
9. Complete paint layer damaged during installation.

Torque settings for nuts and bolts (8,8):	
<b>M 8 - 25 Nm</b>	<b>M 10 - 55 Nm</b>
<b>M 12 - 85 Nm</b>	<b>M 14 - 135 Nm</b>

### NOTE

After install the towbar you should get adequate note in registration book (at authorised service station).The car should be equipped with:

- Indicators
- Tow mirrors

After 1000km check all bolts and nuts. The ball of towbar must be always kept clear and conserve with a grease.