

# AUTO-HAK Sp. z o.o.

ul. Słoneczna 16K 76-200 SŁUPSK  
POLAND

tel/fax +48 59 8 414 414; +48 59 8 414 413

e-mail: [office@autohak.com.pl](mailto:office@autohak.com.pl)

[www.autohak.com.pl](http://www.autohak.com.pl)



# AUTO-HAK

## PEUGEOT PARTNER III (L2)

osobowy/passenger car, dostawczy/VAN, L=4753 mm

## PEUGEOT RIFTER XL (L2)

osobowy/passenger car, dostawczy/VAN, L=4753 mm

## CITROEN BERLINGO III XL (L2)

osobowy/passenger car, dostawczy/VAN, L=4753 mm

## OPEL COMBO III XL (L2)

osobowy/passenger car - Life, dostawczy/VAN - Cargo, L=4753 mm

 06.2018 →

Nr kat.  
**F50A**



1,5h

## FIAT DOBLO (+ E-DOBLO) przedłużony/extended VAN

osobowy/passenger car, dostawczy/VAN, L=4753 mm

 06.2022 →

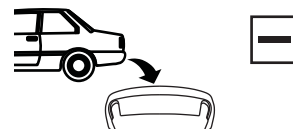

## TOYOTA PROACE CITY (Long)

osobowy/passenger car (Verso), dostawczy/VAN, L=4753mm

 05.2019 →



**E20**

**E20-55R-02 5657**

**D**

9,41 kN



R=1600 kg





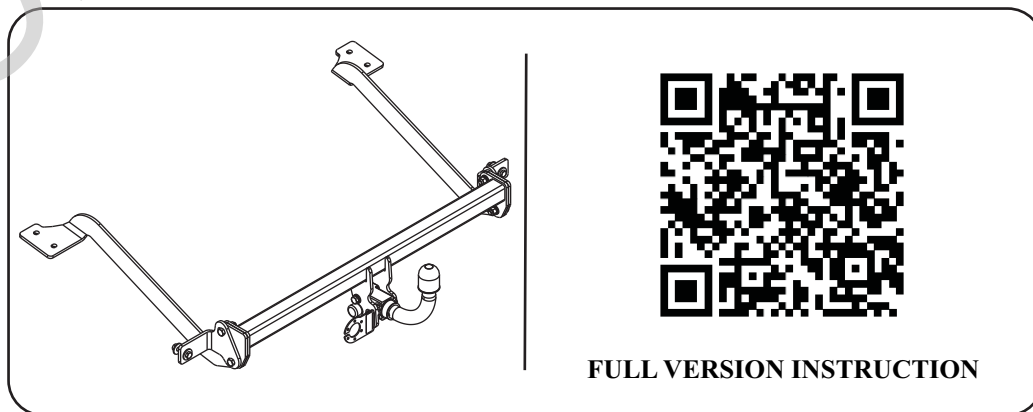



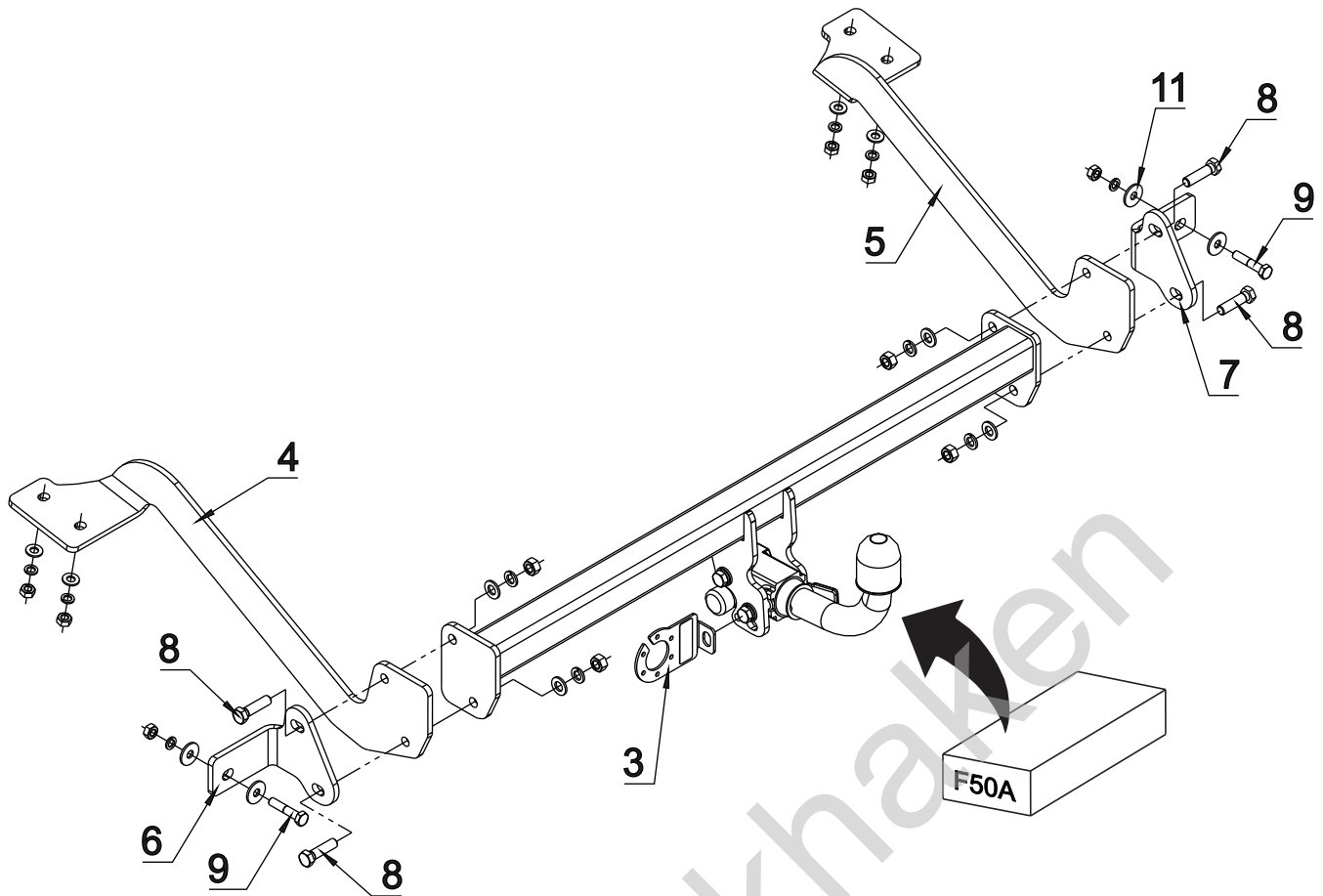

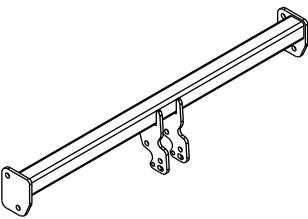
S=75 kg

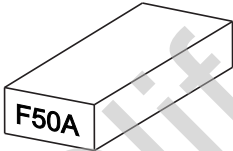

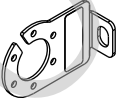

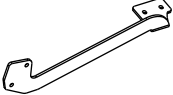
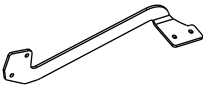
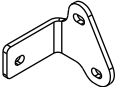
FULL VERSION INSTRUCTION

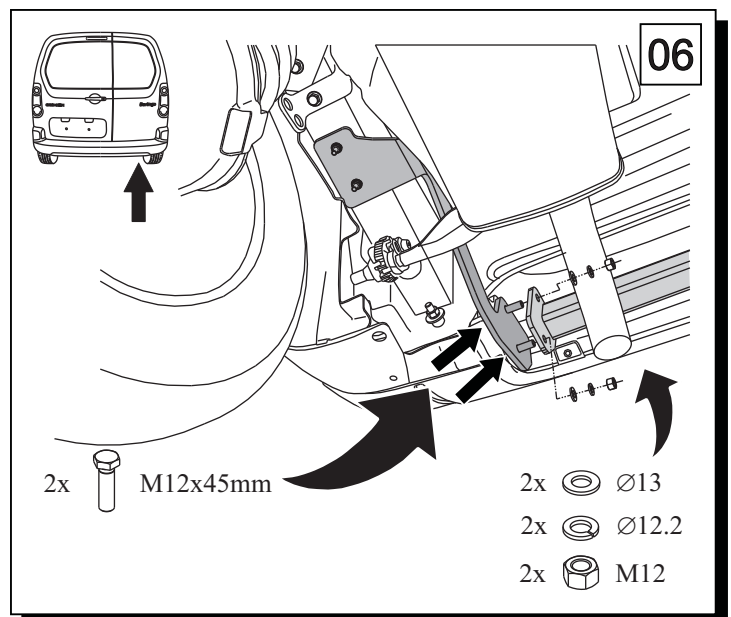
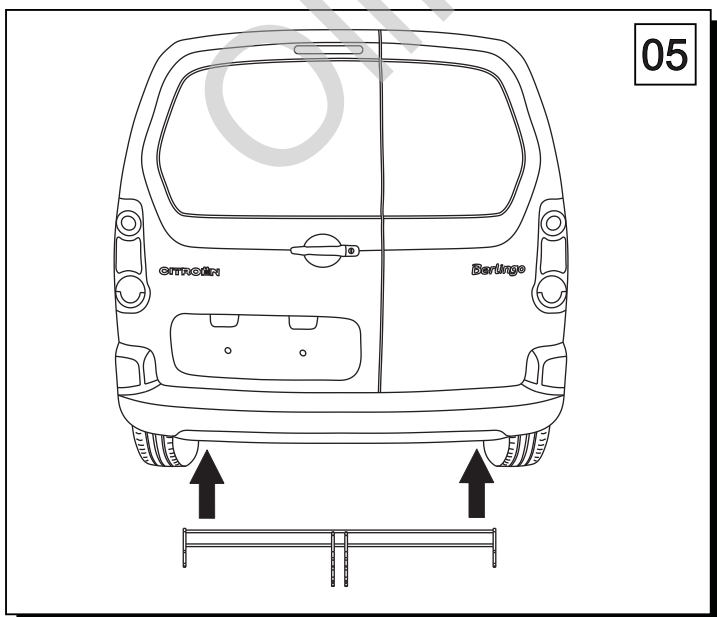
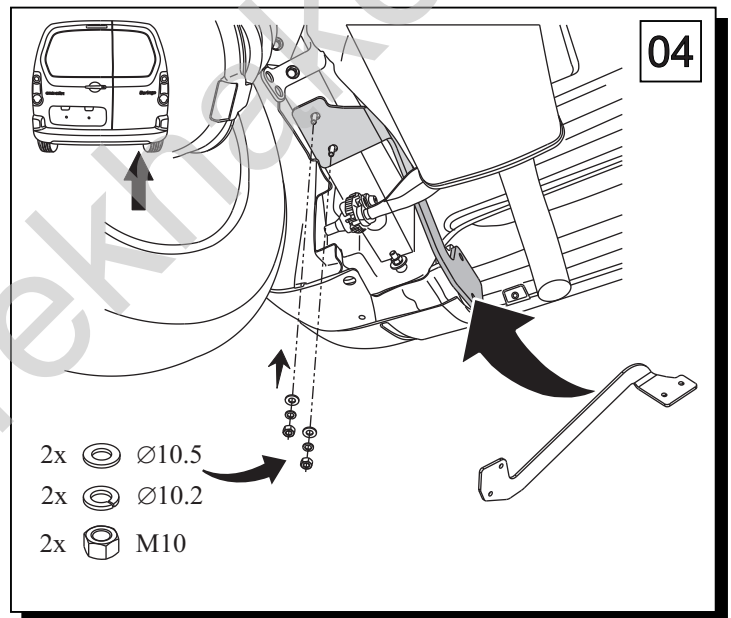
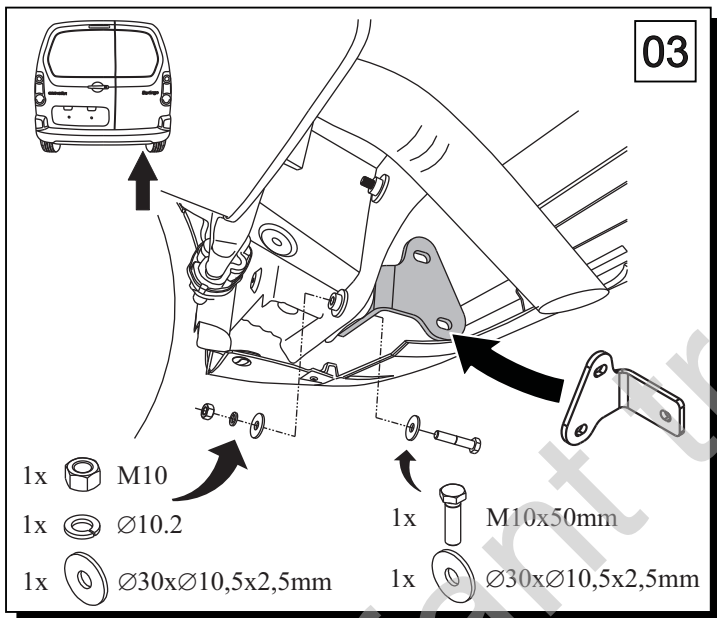
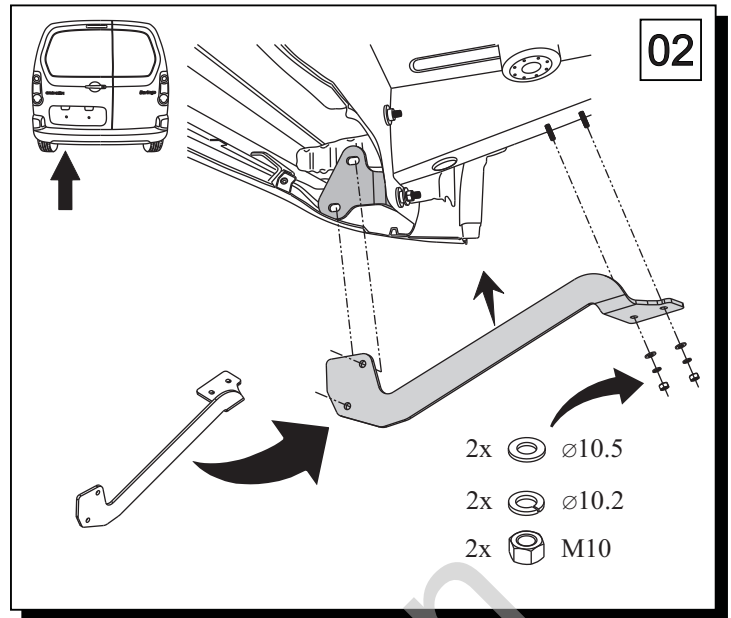
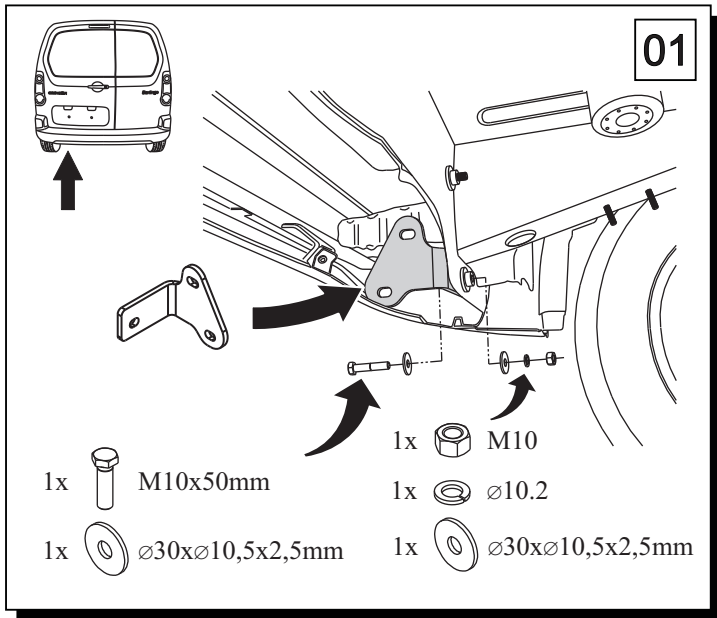

|   |   |     |   |    |                               |     |
|---|---|-----|---|----|-------------------------------|-----|
| 1 |  | x 1 |  | 8  | M12x45                        | x 4 |
|   |   |     |   | 9  | M10x50                        | x 2 |
| 2 |  | x 1 |  | 10 | ∅ 13                          | x 4 |
|   |   |     |   | 11 | ∅ 30x∅10.5x2.5<br>10 DIN 9021 | x 4 |
|   |   |     |   | 12 | ∅ 10.5                        | x 4 |
|   |   |     |   | 13 | ∅ 12.2                        | x 4 |
| 3 |  | x 1 |  | 14 | ∅ 10.2                        | x 6 |
|   |   |     |   | 15 | M12                           | x 4 |
|   |   |     |   | 16 | M10                           | x 6 |
| 4 |  | x 1 |   |    |                               |     |
| 5 |  | x 1 |   |    |                               |     |
| 6 |  | x 1 |   |    |                               |     |
| 7 |  | x 1 |   |    |                               |     |

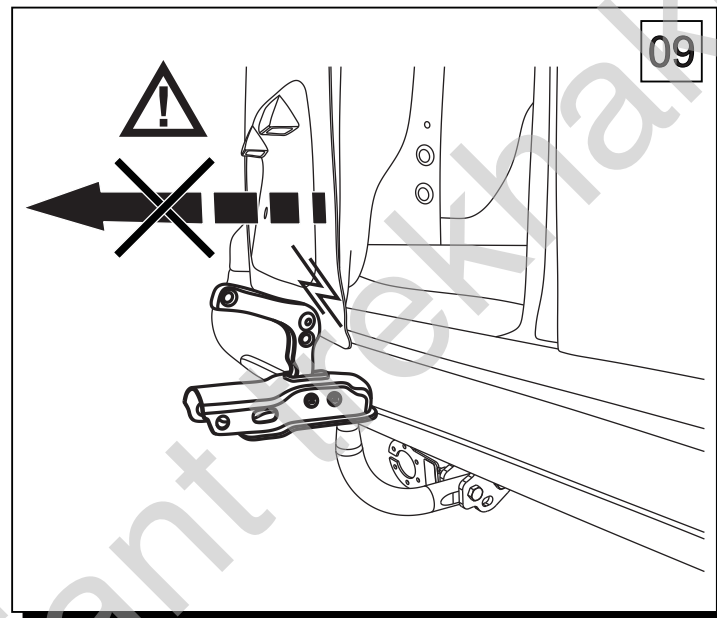
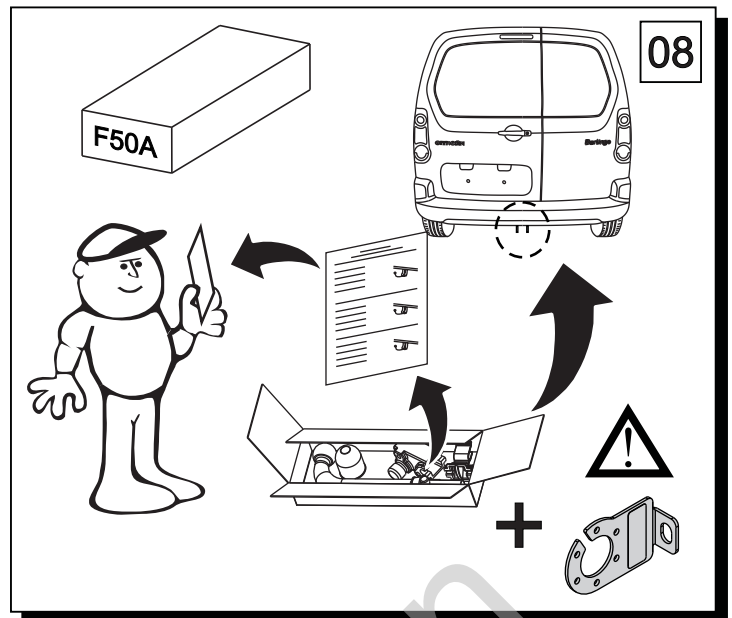
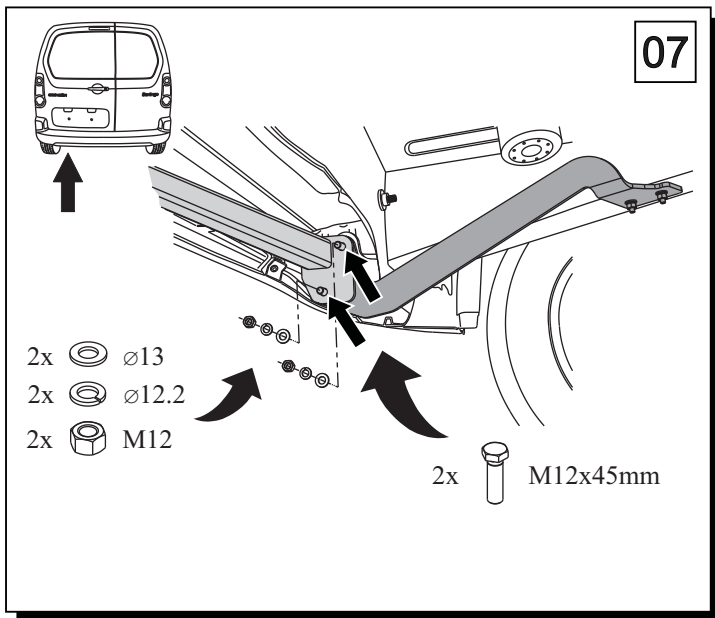

| šruba<br>Nm | M6  | M8 | M10 | M12 | M14 | M16 |
|-------------|-----|----|-----|-----|-----|-----|
| klasa 8.8   | 9,9 | 24 | 48  | 83  | 132 | 200 |
| klasa 10.9  | 14  | 34 | 67  | 117 | 185 | 285 |

0 km → 1000 km