

AUTO-HAK Sp. z o.o.

ul. Słoneczna 16K 76-200 SŁUPSK
POLAND

tel/fax +48 59 8 414 414; +48 59 8 414 413

e-mail: office@autohak.com.pl

www.autohak.com.pl



AUTO-HAK

PEUGEOT E-5008 (ELECTRIC)

⌚ 2024 →

**PEUGEOT 5008 III (mHEV HYBRID
Plug-in HYBRID)**

⌚ 10.2024 →

Nr kat.

F56

E20

E20*55R02*7002



2h

D

11,0 kN

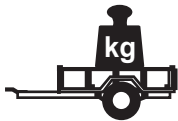

R=2000 kg



S=85 kg

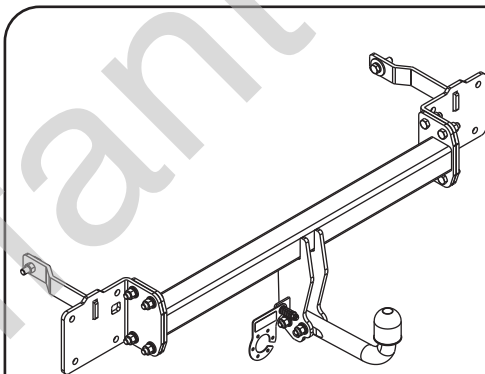

FULL VERSION INSTRUCTION



| śruba | Nm | M6 | M8 | M10 | M12 | M14 | M16 |
|------------|----|-----|----|-----|-----|-----|-----|
| klasa 8.8 | | 9,9 | 24 | 48 | 83 | 132 | 200 |
| klasa 10.9 | | 14 | 34 | 67 | 117 | 185 | 285 |









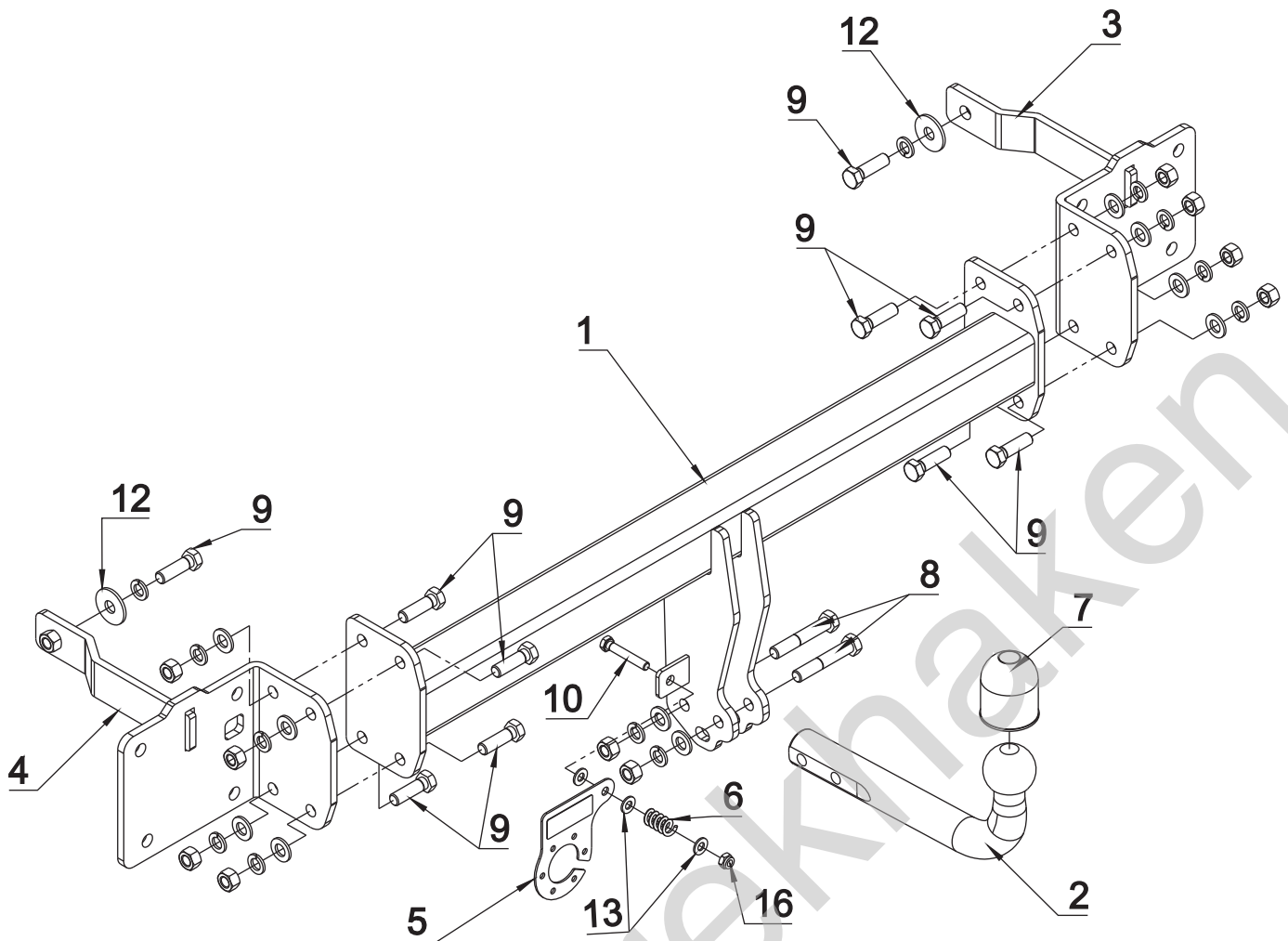

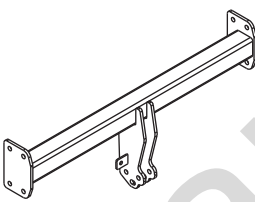





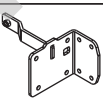

0 km →

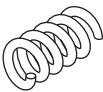

1000 km



| | | | | | |
|----------|---|-----------------------------|---|---|-------------|
| 1 |  | x 1 |  | 8 M12x70 | x 2 |
| 2 |  | x 1 Art.nr-KL1F56 |  | 9 M12x40 | x 10 |
| 3 |  | x 1 |  | 10 M8x50 | x 1 |
| 4 |  | x 1 |  | 11 \varnothing 13 | x 10 |
| 5 |  | x 1 Art.nr-BL1F56 |  | 12 \varnothing 37x \varnothing 13x3 13 (DIN 9021) | x 2 |
| 6 |  | x 1 |  | 13 \varnothing 8.4 | x 3 |
| 7 |  | x 1 |  | 14 \varnothing 12.2 | x 12 |
| | | |  | 15 M12 | x 10 |
| | | |  | 16 M 8 (DIN985) | x 1 |

01

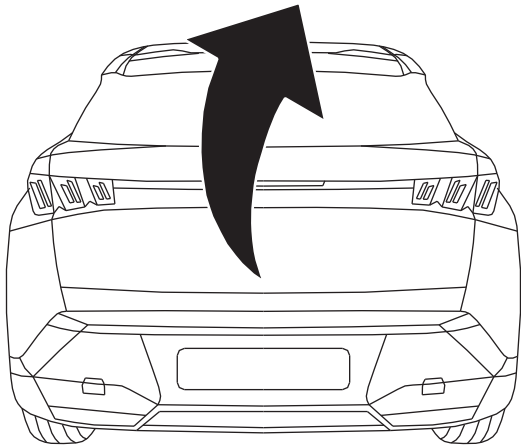

02

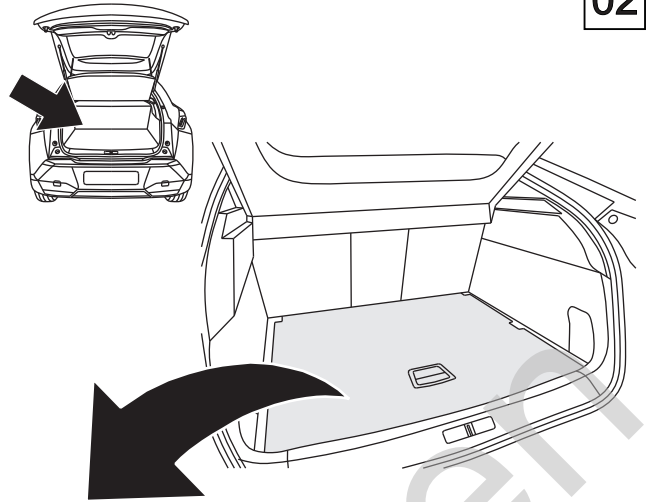

03

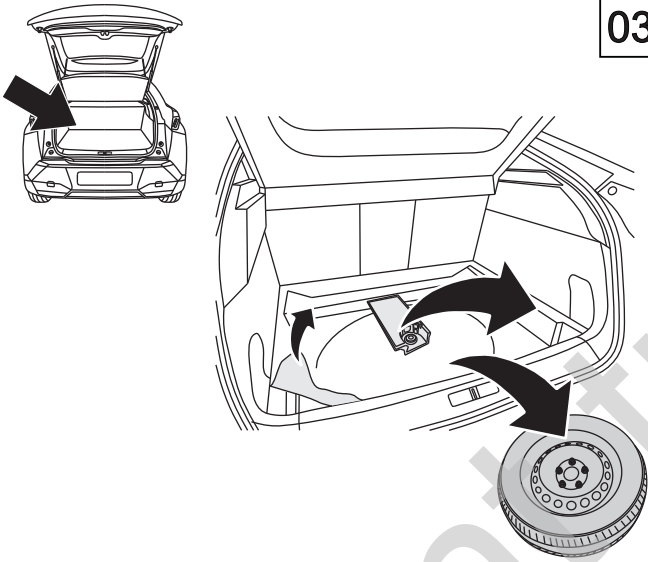

04

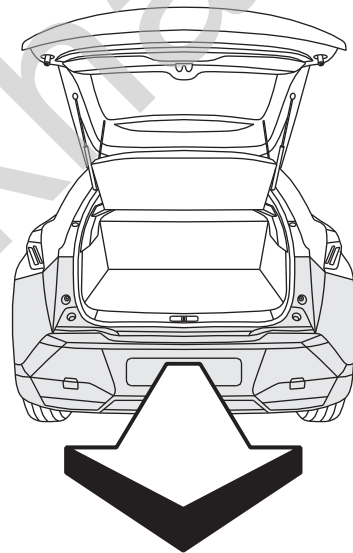

05

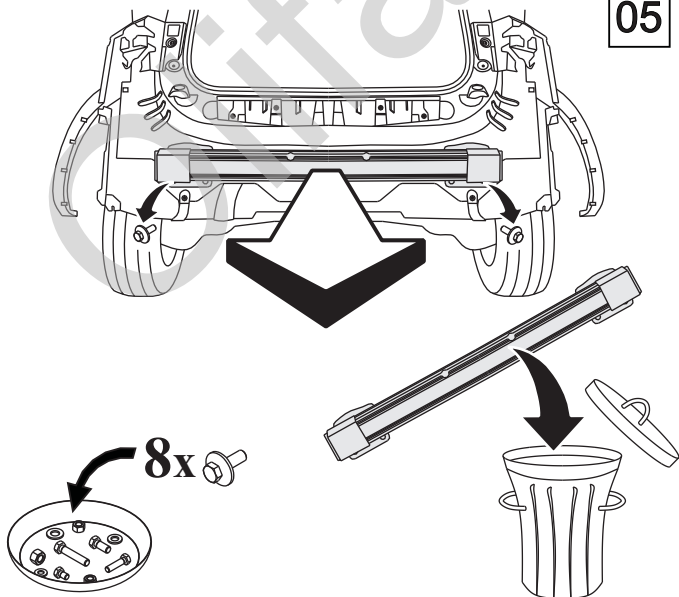

06

