

AUTO-HAK Sp. z o.o.

ul. Słoneczna 16K 76-200 SŁUPSK
POLAND

tel/fax +48 59 8 414 414; +48 59 8 414 413

e-mail: office@autohak.com.pl

www.autohak.com.pl



AUTO-HAK

PEUGEOT 307 3/5 D

⌚ 05.2001 → 09.2007

PEUGEOT 308 3/5 D ~~GTI, Sport~~

! przed liftingiem !

⌚ 10.2007 → 2010

Nr kat.

F24A

E20 E20-55R-01 4735

D 9,22 kN

 R=1700 kg

 S=76 kg



1,5h

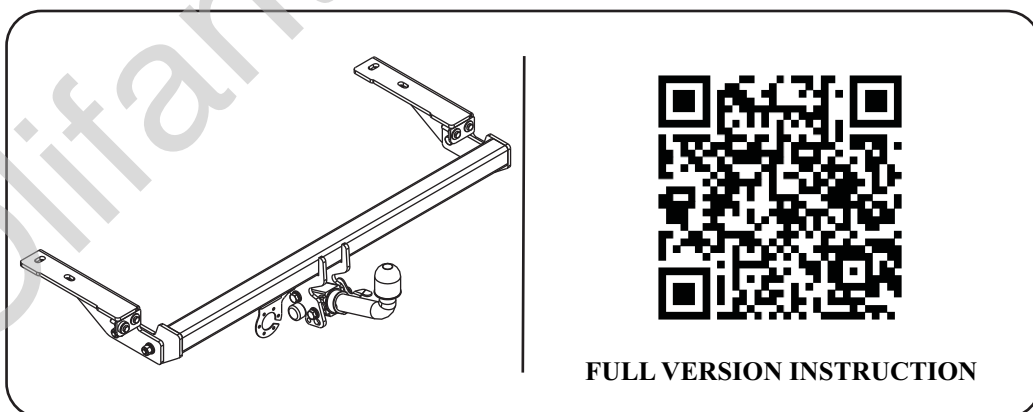

FULL VERSION INSTRUCTION



śruba	Nm	M6	M8	M10	M12	M14	M16
klasa 8.8		9,9	24	48	83	132	200
klasa 10.9		14	34	67	117	185	285

 0 km →  1000 km

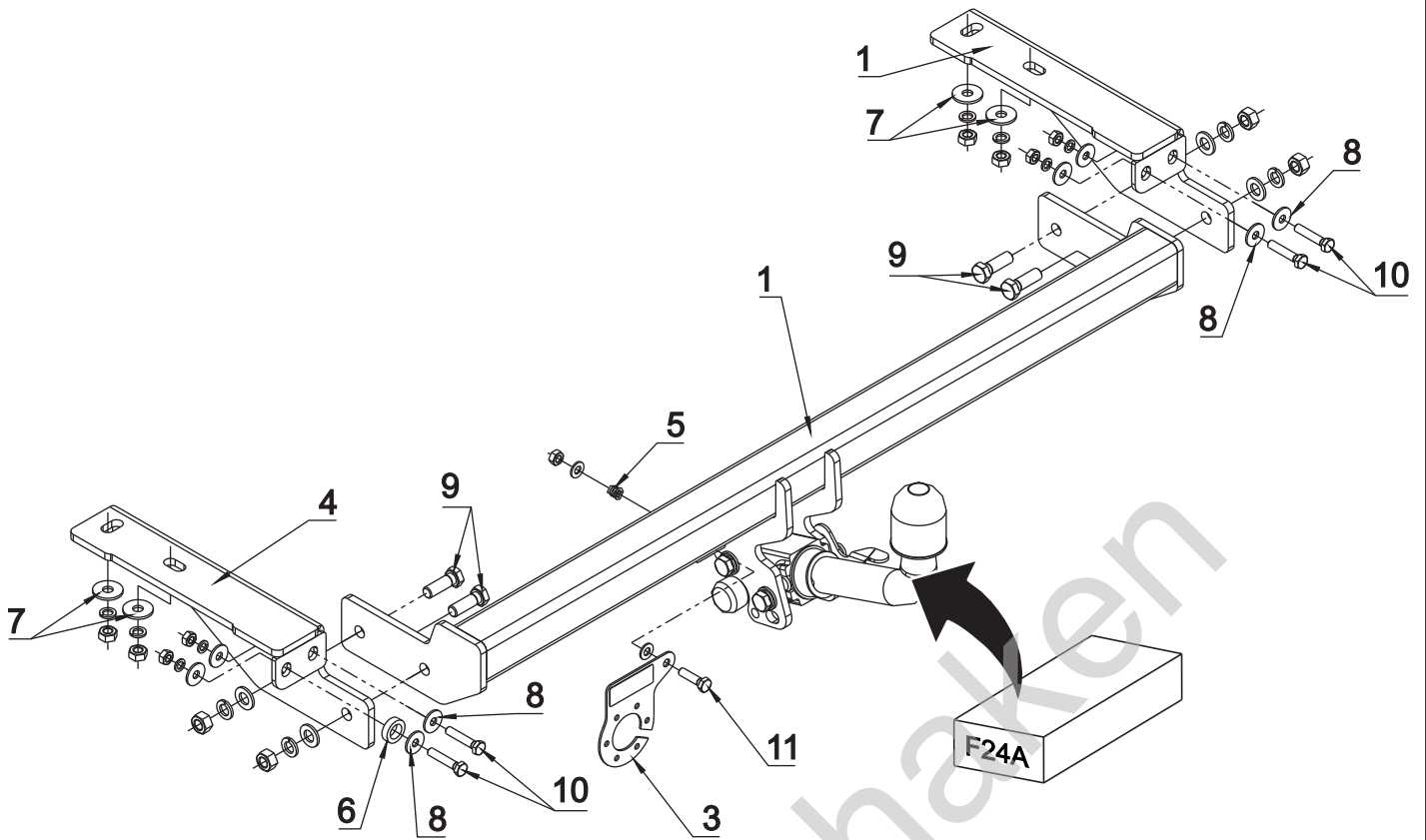

1		x1		6	$\phi 25 \times \phi 16, L=7$	x1
				7	$\phi 30 \times \phi 10.5 \times 2.5$	x4
2		x1		9	M12x35	x4
				10	M8x40	x4
3		x1		11	M8x45	x1
				12	M12	x4
4		x2		13	M10	x4
				14	M8	x5
5		x1		15	$\phi 13$	x4
				16	$\phi 8$	x2
5		x1		17	$\phi 12.2$	x4
				18	$\phi 10.2$	x4
5		x1		19	$\phi 8.2$	x4
				20		x1

