

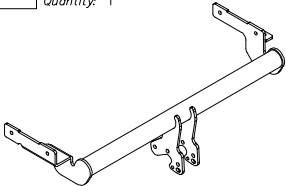







Towbar accessories:

Pos. 1 Name: Main bar Quantity: 1	Pos. 4 Name: Ball cover Quantity: 1	Pos. 8 Name: Nut 8 B Quantity: 1 Dim.: M10
		
	Pos. 5 Name: Cut washer Quantity: 2	Pos. 9 Name: Plain washer Quantity: 7 Dim.: Ø 10,5 mm
		
Pos. 2 Name: Tow-ball Quantity: 1	Pos. 6 Name: Bolt 8,8 B Quantity: 1 Dim.: M10x75mm	Pos. 10 Name: Spring washer Quantity: 7 Dim.: Ø 10,2 mm
		
Pos. 3 Name: Socket plate Quantity: 1	Pos. 7 Name: Bolt 8,8 B Quantity: 6 Dim.: M10x1.25x30mm	Pos. 11 Name: Distance sleeve Quantity: 2 Dim.: Ø25x6mm
		

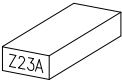
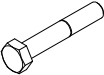

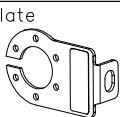
PPUH AUTO-HAK S.J.

Produkcja Zaczepów Kulowych
Henryk & Zbigniew Nejman
76-200 SŁUPSK ul. Słoneczna 16K
tel/fax (059) 8-414-414; 8-414-413
E-mail: office@autohak.com.pl
www.autohak.com.pl

Towing hitch (without electrical set)

Class: **A50-X** Cat. no. **Z23A**

Designed for:

Manufacturer: **MITSUBISHI**

Model: **CARISMA**

Type: **4/5 doors (DA)**

produced since 07.1995 till 06.2006

Technical data:

D-value: 7,63 kN

maximum trailer weight: **1450 kg**

maximum vertical cup load: **75 kg**

Approval number according to Directive 94/20/EC: **e20*94/20*1035*00**

Foreword

This towbar is designed according to rules of safety traffic regulations. The towing hitch is a safety component and must be installed only by qualified personnel. Any alteration or conversion to the towing hitch is prohibited and would lead to cancellation of design certification. Remove insulating compound and underseal from vehicle (if present) in the area of the matting surfaces of the towing hitch. The vehicle manufacturer's specifications regarding trailer load and max. vertical cup load are decisive for driving, and values for the towing hitch must not be exceeded.

D-value formula:

$$\frac{\text{Max trailer weight [kg]} \times \text{Max vehicle weight [kg]}}{\text{Max trailer weight [kg]} + \text{Max vehicle weight [kg]}} \times \frac{9,81}{1000} = D \text{ [kN]}$$

FITTING INSTRUCTION

Clamp mark in acc. with		Cables joining
ISO	PN	
1	L	Left directional lights
2	+	Rear fog lights
3	31	Ground
4	R	Right directional lights
5	58R	Right side parking lights
6	54	Stoplights
7	58L	Left side parking lights

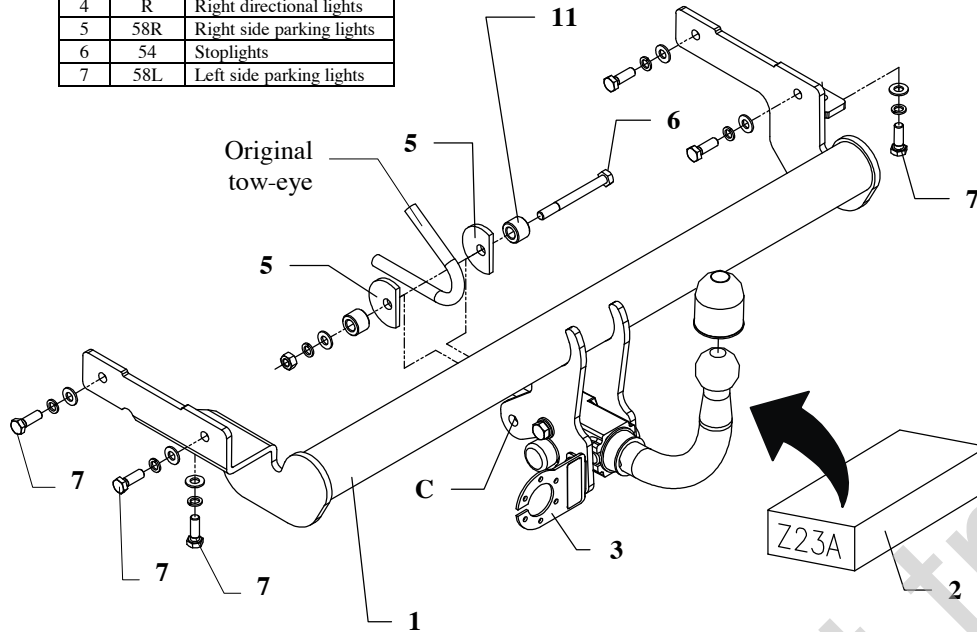

This towbar is designed to assembly in following car:
MITSUBISHI CARISMA 4/5 door (DA), produced since 07.1995 till 06.2006, catalogue number **Z23A** and is prepared to tow trailers max total weight **1450 kg** and max vertical load **75 kg**.

From manufacturer

Thank you for buying our product. Their reliability has been confirmed in many tests. Reliability of towbar depends also on correct assembly and right operation. For this reasons we kindly ask to read carefully this instruction and apply to hints.

The towbar should be install in points described by a car producer.

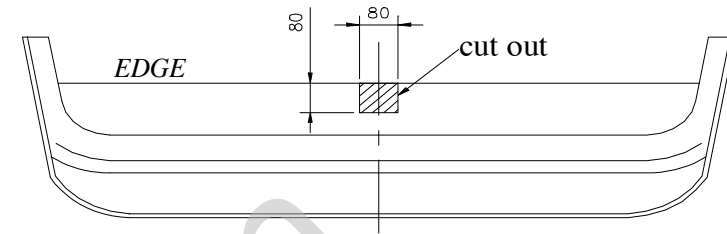

Fig. 2

Fitting instructions

1. Disassemble the bumper and then, unscrew the muffler and heat-proof casing.
2. For models till 1999; cut a hole, on the lower edge of the bowl of the bumper as shown in the fig. 2. For models from year 2000, you must check dimensions of cut out fragment.
3. Apply the main bar (pos. 1) to the chassis members of the car and twist in the designed places by the manufacturer, with screws M10x1,25x30mm (pos. 7).
4. Through hole of the towbar (pos. C) and original tow-eye, fix by M10x100mm bolts (pos. 6) using cut washers (pos. 5) and distance sleeves (pos. 11).
5. Assemble the bumper and heat-proof casing.
6. Fix body of the automat and place tow-ball according to supplied instruction. Note! Remember to place socket plate (pos. 3) as shown on the drawing 1.
7. Screw all bolts according to the torque shown in the table.
8. Connect electric wires according to the instruction of the car. (Recommend to make at authorized service station)
9. Supplement the paint coating damaged during assembly.

Torque settings for nuts and bolts (8,8):

M 8	25 Nm	M 10	55 Nm
M 12	85 Nm	M 14	135 Nm

NOTE

After install the towbar you should get adequate registration in registration book (at authorised service station).The car should be equipment with:

- Indicators
- Tow mirrors

After 1000km of exploitation check all bolts and nuts. The ball of towbar must be always keep clear and conserve with a grease.