

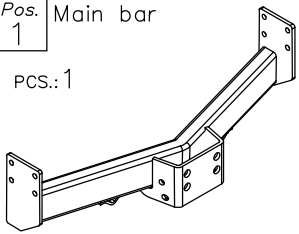

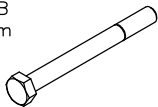





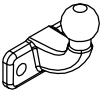

Towing hitch accessories:

Pos. 1 Main bar PCS.: 1 	Pos. 5 Bolt 8,8 B M10x90mm PCS.: 8 	Pos. 10 Spring washer ø10mm PCS.: 9 
	Pos. 6 Bolt 8,8 B M10x30mm PCS.: 1 	Pos. 11 Nut 8 B M16 PCS.: 2 
Pos. 2 Tow ball PCS.: 1 	Pos. 7 Plain washer ø17mm PCS.: 2 	Pos. 12 Nut 8 B M10 PCS.: 9 
Pos. 3 Socket plate PCS.: 1 	Pos. 8 Plain washer ø10mm PCS.: 9 	Pos. 13 Ball cover PCS.: 1 
Pos. 4 Bolt 8,8 B M16x50mm PCS.: 2 	Pos. 9 Spring washer ø16.3mm PCS.: 2 	

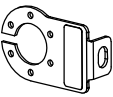

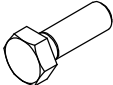
PPUH AUTO-HAK Sp.J.

Produkcja Zaczepów Kulowych
Henryk & Zbigniew Nejman
76-200 SŁUPSK ul. Słoneczna 16K
tel/fax (059) 8-414-414; 8-414-413
E-mail: office@autohak.com.pl
www.autohak.com.pl

Towing hitch (without electrical set)

Class: **A50-X** Cat. no. **D05**

Designed for:

Manufacturer: **MERCEDES**

Model: **207, 208, 209, 210**

Type: **metal built-up**

produced since 1977 till 1995

Technical data:

D-value: 13,8 kN

maximum trailer weight: **2000 kg**

maximum vertical cup mass: **100 kg**

Approval number according to Directive 94/20/EC: **e20*94/20*0392*00**

Foreword

This towing hitch is designed according to rules of safety traffic regulations. The towing hitch is a safety component and can be install only by qualified personnel. Any alteration or conversion of the towing hitch is prohibited and would lead to cancellation of design certification. Remove insulating compound and underseal from vehicle (if present) in the area of the matting surfaces of the towing hitch. The vehicle manufacturer's specifications regarding trailer mass and max. vertical cup mass are decisive for driving whereat values for the towing hitch cannot be exceeded.

D-value formula:

$$\frac{\text{Max trailer weight [kg]} \times \text{Max vehicle weight [kg]}}{\text{Max trailer weight [kg]} + \text{Max vehicle weight [kg]}} \times \frac{9,81}{1000} = D \text{ [kN]}$$

FITTING INSTRUCTION

Clamp mark in acc. with		Cables joining
ISO	PN	
1	L	Left directional lights
2	+	Rear fog lights
3	31	Ground
4	R	Right directional lights
5	58R	Right side parking lights
6	54	Stoplights
7	58L	Left side parking lights

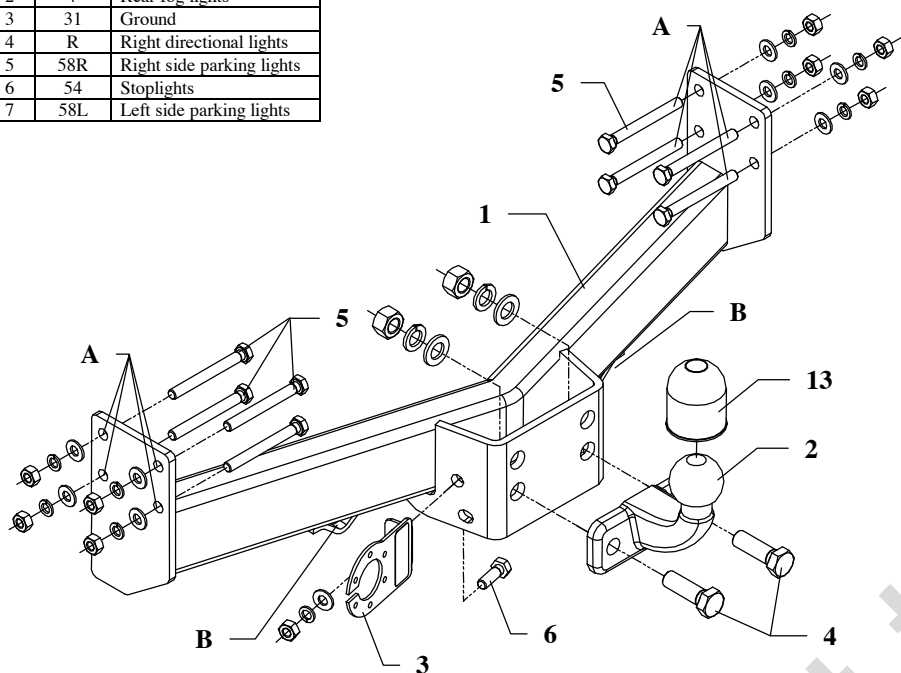

This towing hitch is designed to assembly in following cars: **MERCEDES 207, 208, 209, 210, metal built-up**, produced since 1977 till 1995, catalogue no. **D05** and is prepared to tow trailers max total weight **2000 kg** and max vertical mass **100 kg**.

From manufacturer

Thank you for buying our product. Their reliability has been confirmed in many tests. Reliability of towing hitch depends also on correct assembly and right operation. For this reasons we kindly ask to read carefully this instruction and apply to hints.

The towing hitch should be install in points described by a car producer.

The instruction of the assembly

1. Unscrew the bolts and disassemble the spare wheel.
2. Apply the main bar of the towing hitch (pos. 1) to frame of the car and through holes of towing hitch (pos. A) and existing holes in the frame fix using bolts M10x90mm (pos. 5) from the towing hitch accessories.
3. The bolts which hold up the spare wheel one ought to shorten and then hang up them on handles of the towing hitch (pos. B).
4. Install the spare wheel.
5. Fix tow-ball (pos. 2) using bolts M16x50mm (pos. 4) from accessories.
6. Fix socket plate (pos. 3) with bolt M10x30mm (pos. 6) as shown on the drawing.
7. Tighten all bolts according to the torque shown in the table.
8. Connect electric wires of 7-poles socket according to the instruction of the car. (Recommend to make at authorized service station).
9. Complete paint layer damaged during installation.

Torque settings for nuts and bolts (8,8):

M6 - 11 Nm	M8 - 25 Nm	M10 - 50 Nm
M12 - 87 Nm	M14 - 138 Nm	M16 - 210 Nm

NOTE

After install the towing hitch you should get adequate note in registration book (at authorised service station). The car should be equipped with:

- Indicators
- Tow mirrors

After 1000km of exploitation check all bolts and nuts. The ball of towing hitch must be always kept clear and conserve with a grease.