

PPUH AUTO-HAK Sp.J.

Henryk & Zbigniew Nejman
ul. Słoneczna 16K 76-200 SŁUPSK
POLAND

tel/fax +48 059 8-414-414; 8-414-413

e-mail: office@autohak.com.pl

www.autohak.com.pl



AUTO-HAK



MAZDA 6 4/5D (GH)

Cat. no:

M56A



03.2008 → 01.2013

e20

e20*94/20*0901*00

D

9,5 kN



2h



R=1600 kg









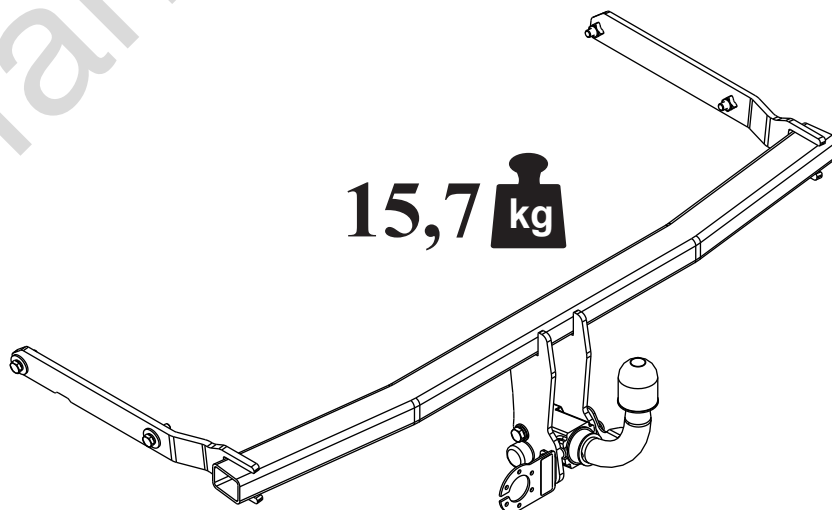

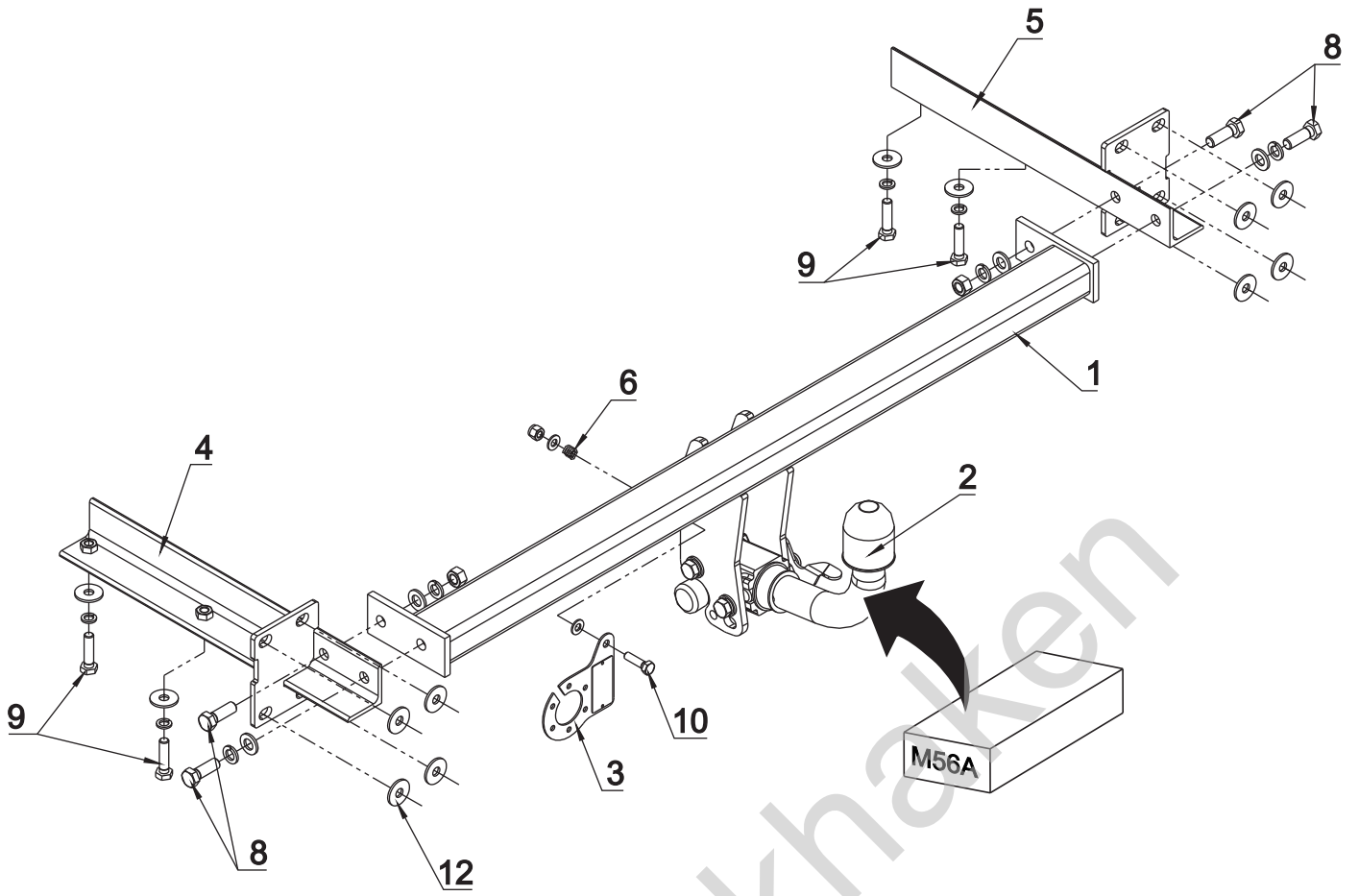

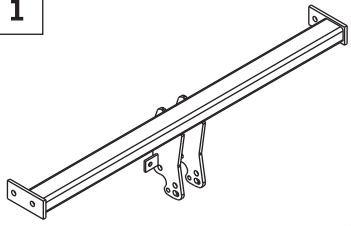

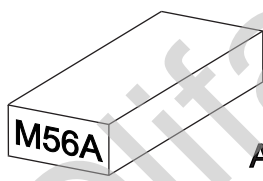
S=75 kg

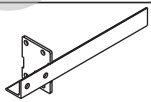

15,7 kg

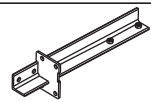



 1	x 1		8 M 12x35	x 4
			9 M 10x40	x 4
 M56A Art.nr-KL1M56A	x 1		10 M 8x30	x 1
			11 \varnothing 13	x 4
 Art.nr-BL1M56A	x 1		12 \varnothing 30x \varnothing 10.5x2.5 10 – DIN 9021	x 12
			13 \varnothing 8,3	x 2
 4	x 1		14 \varnothing 12.2	x 4
			15 \varnothing 10.2	x 4
 5	x 1		16 M 12	x 2
			17 M 8	x 1
 6	x 1			
 7	x 1			

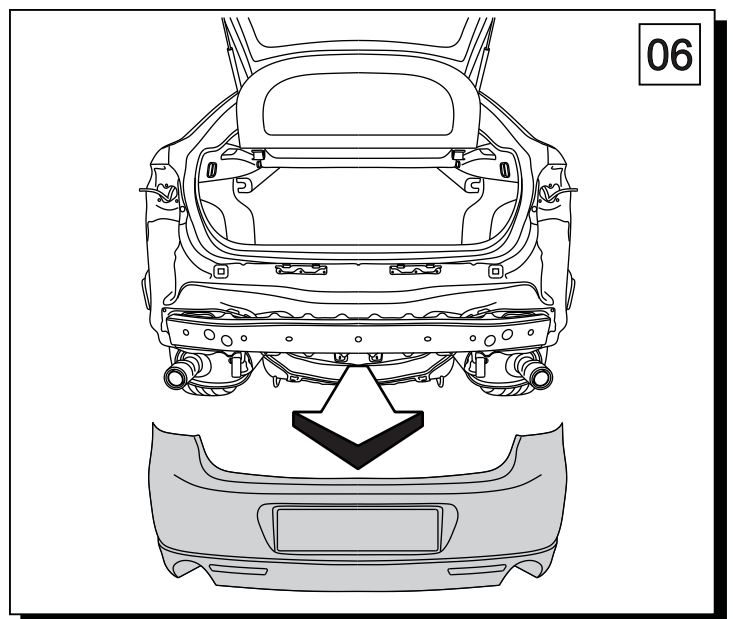
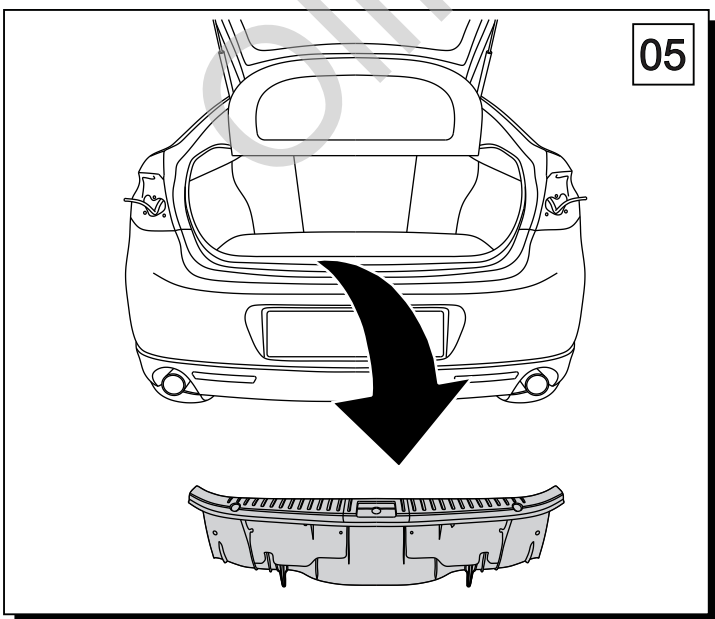
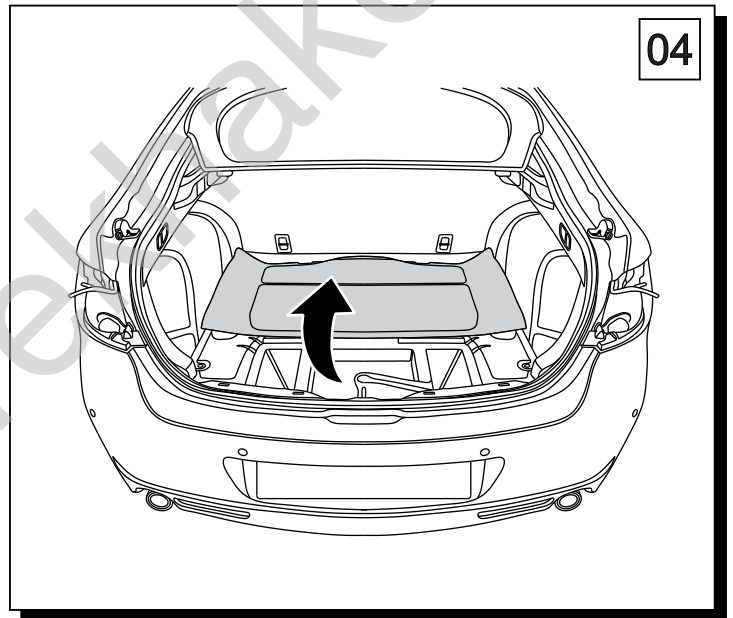
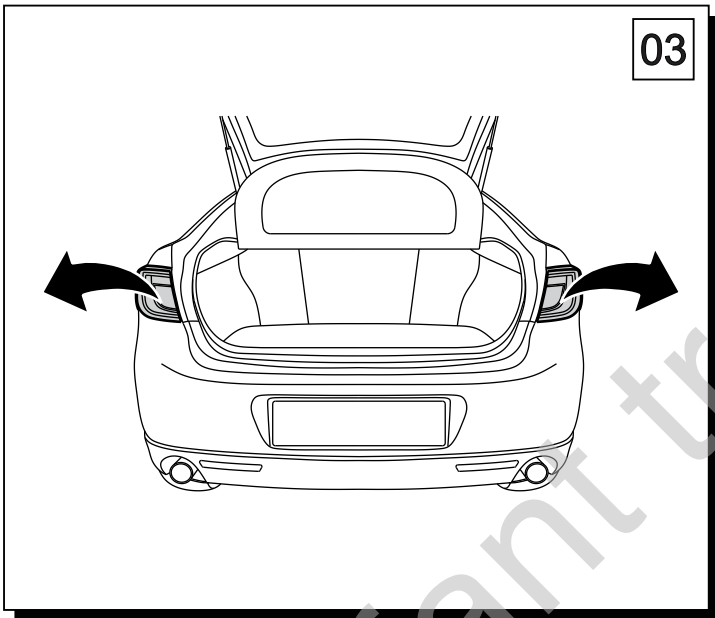
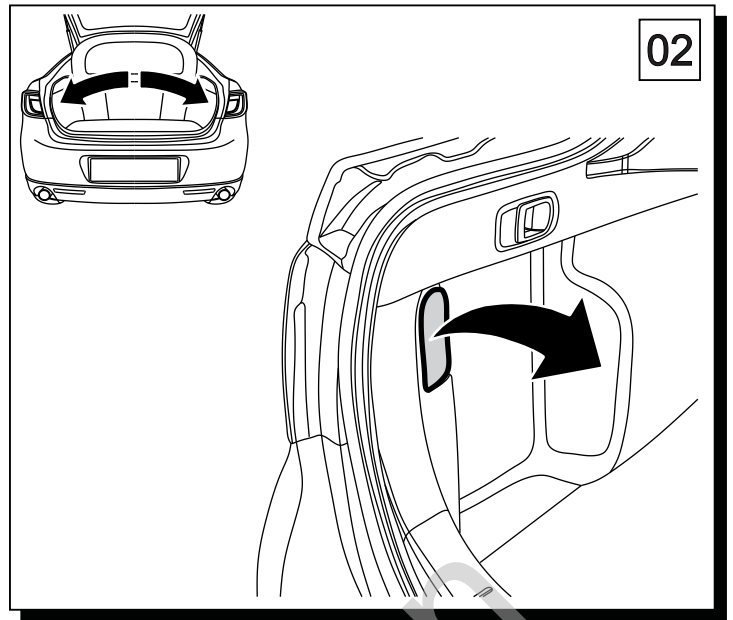
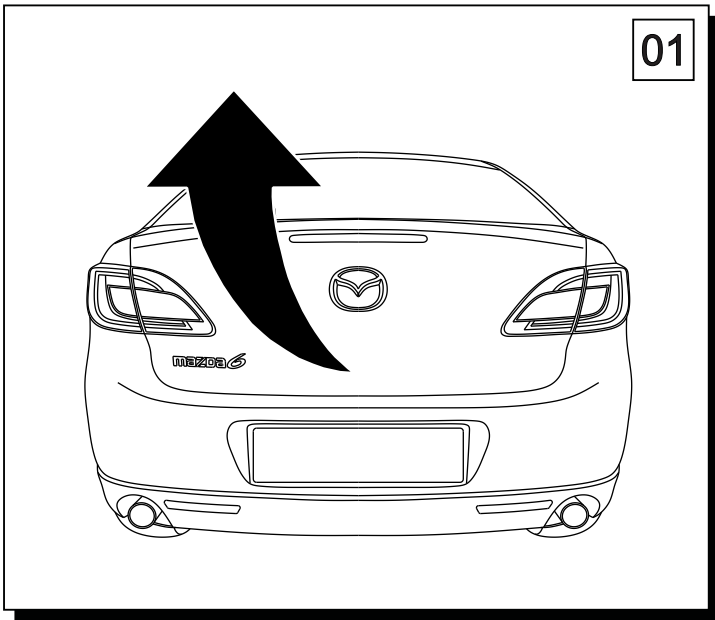

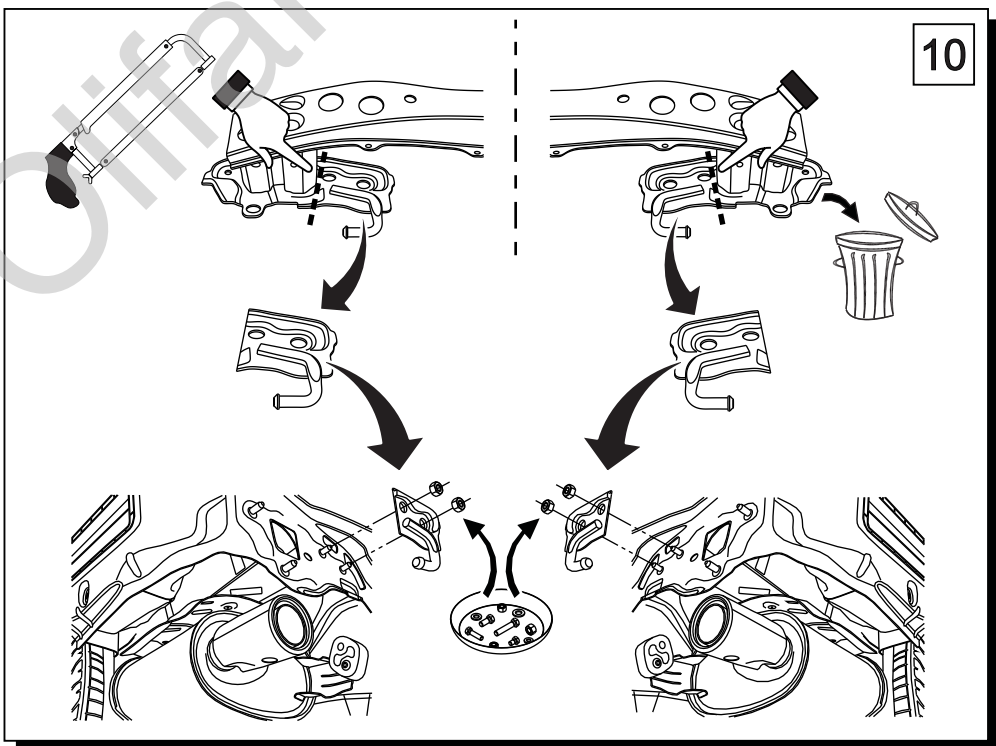
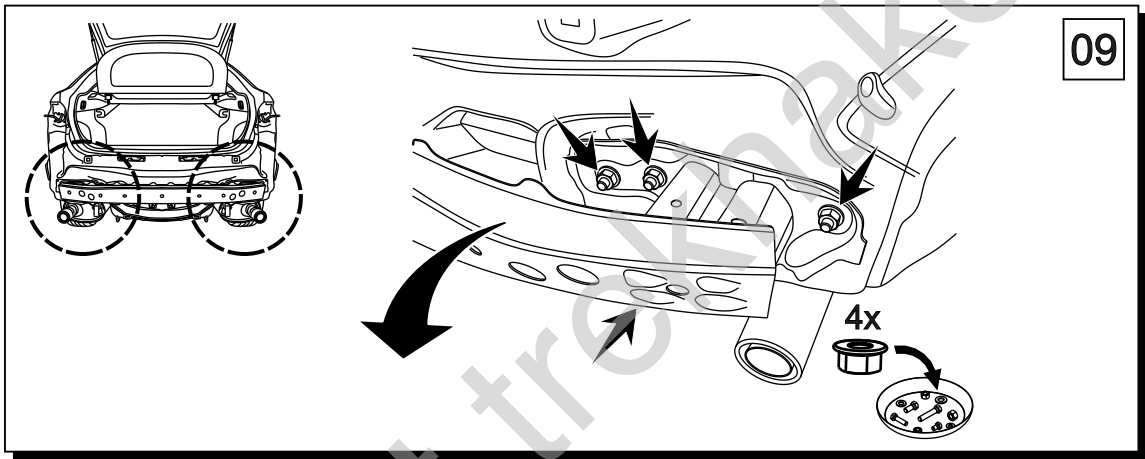
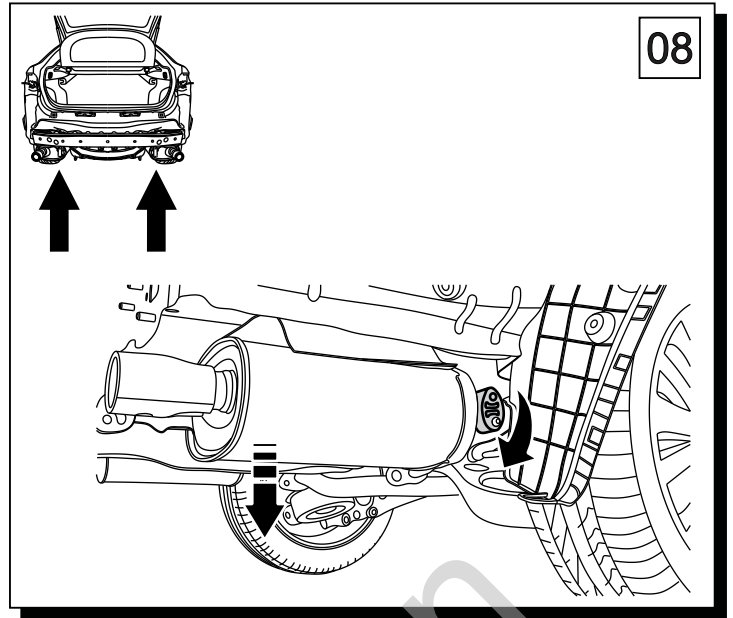
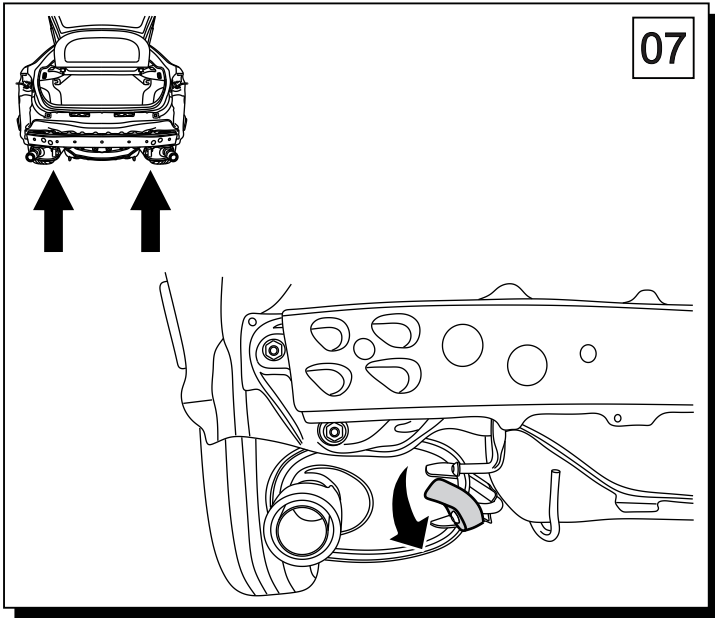

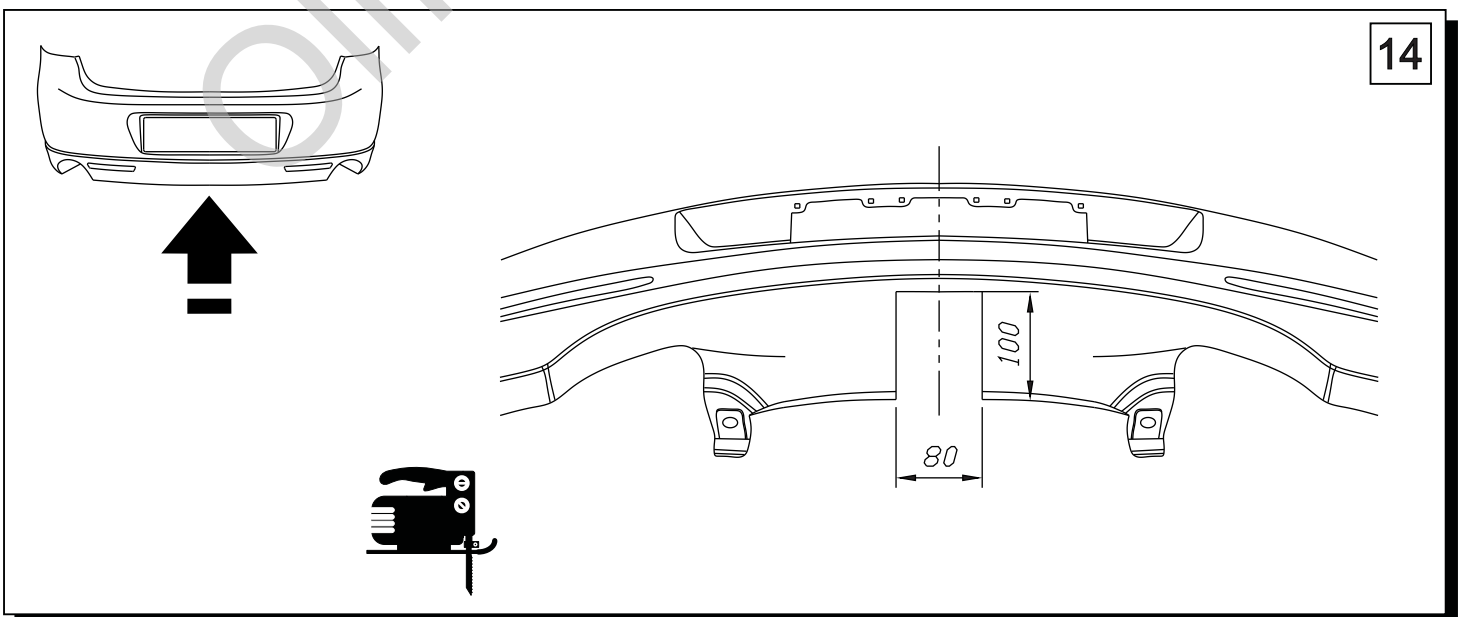
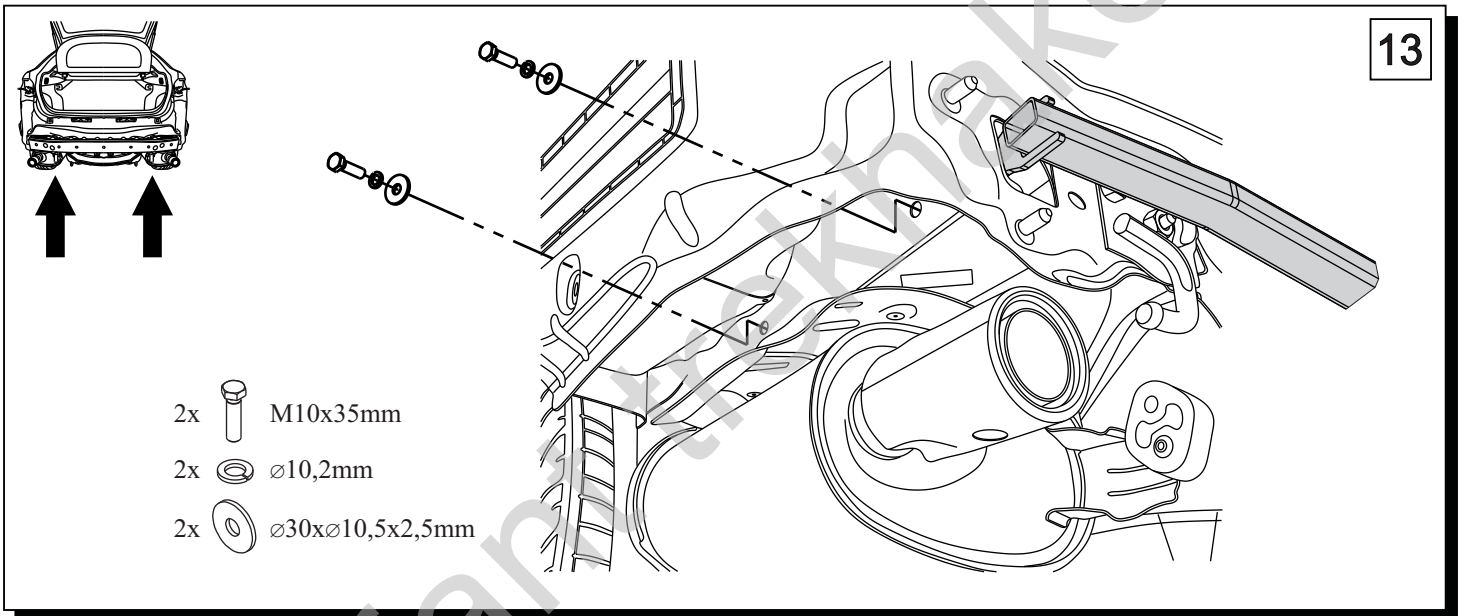
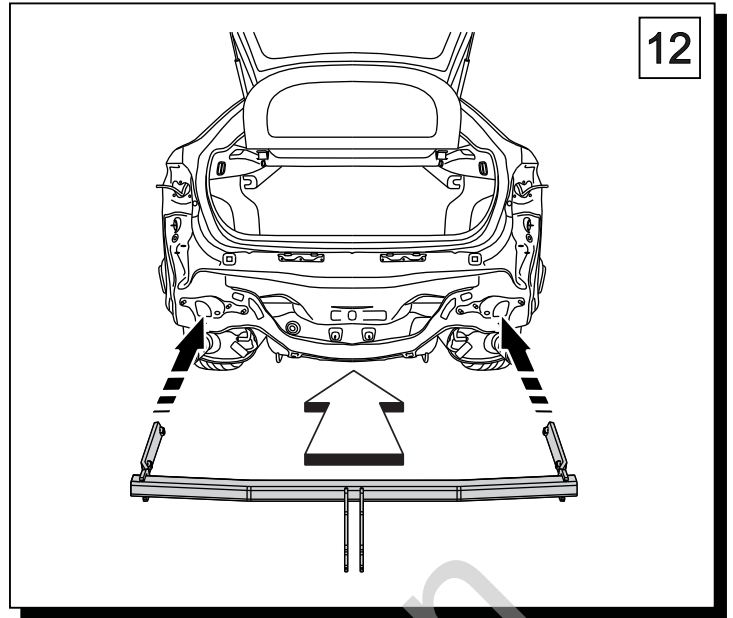
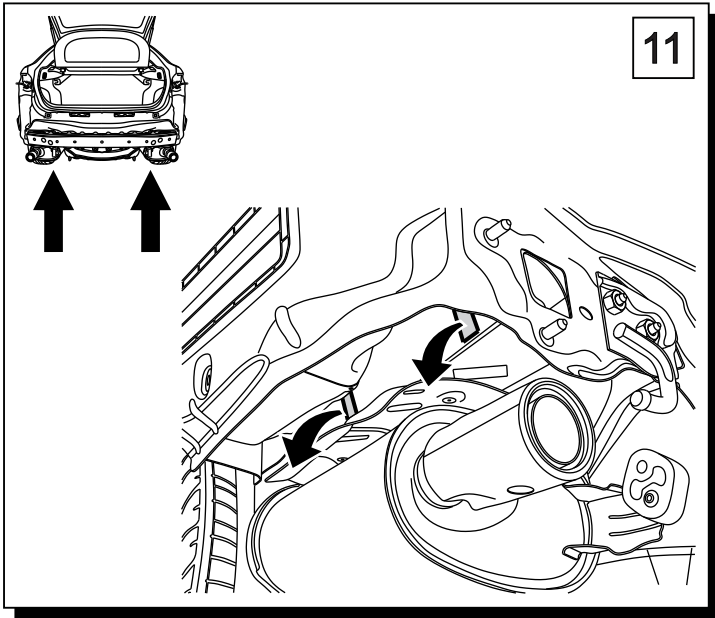

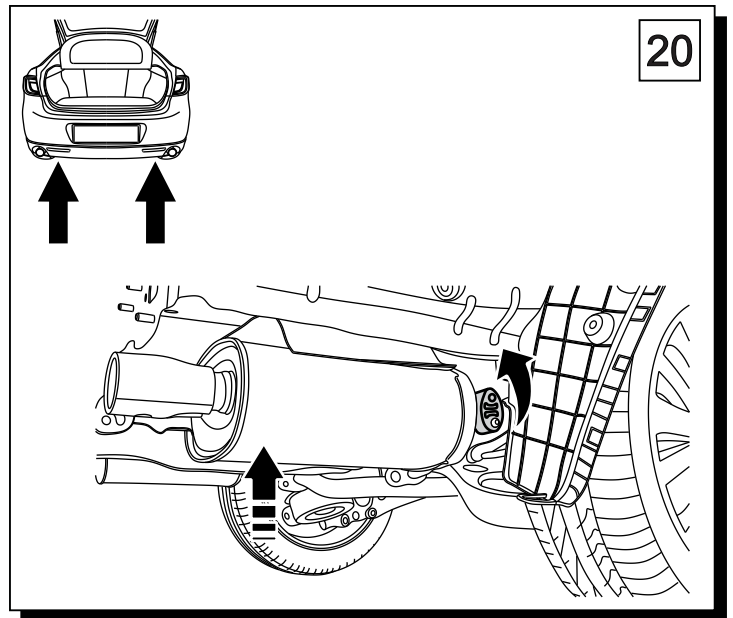
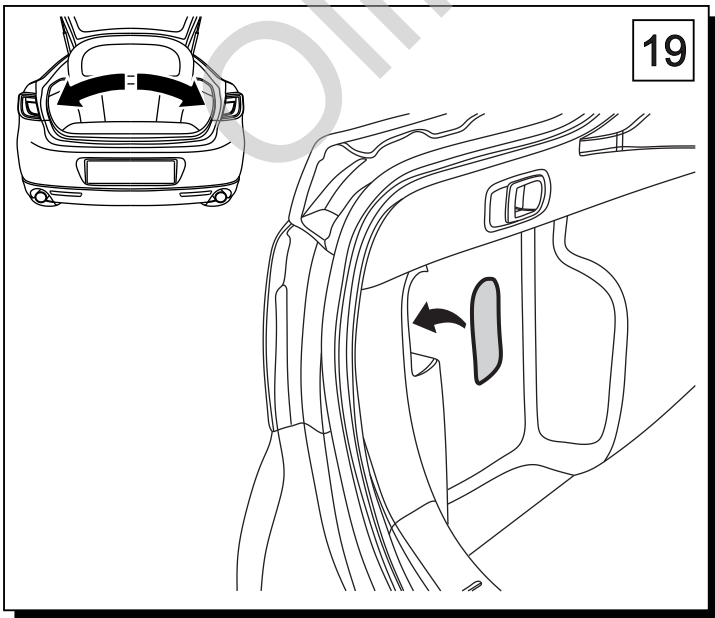
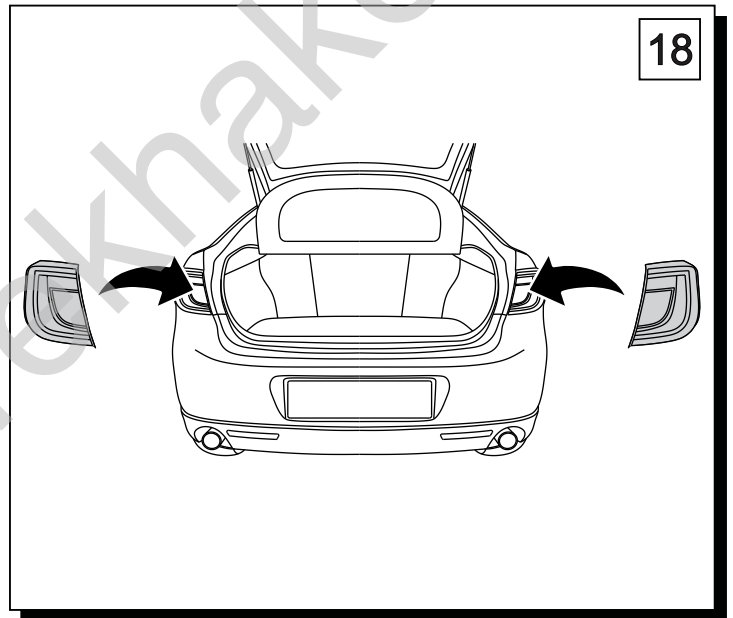
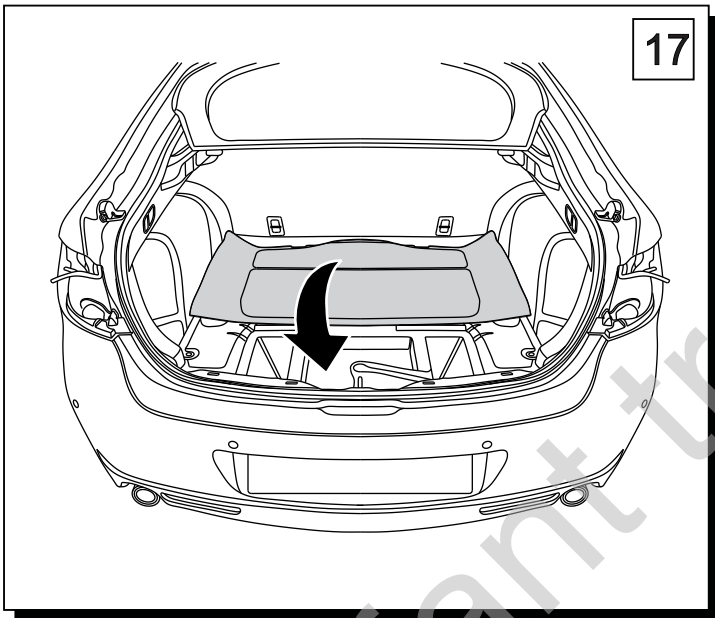
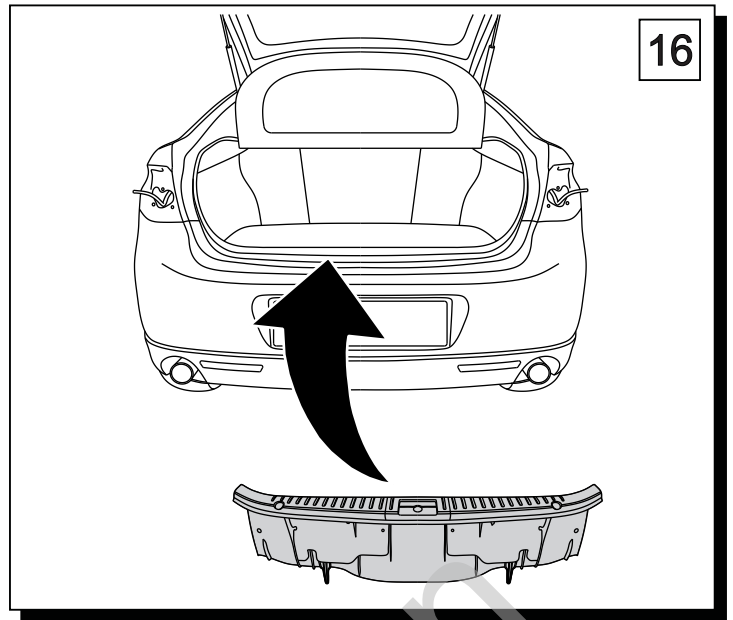
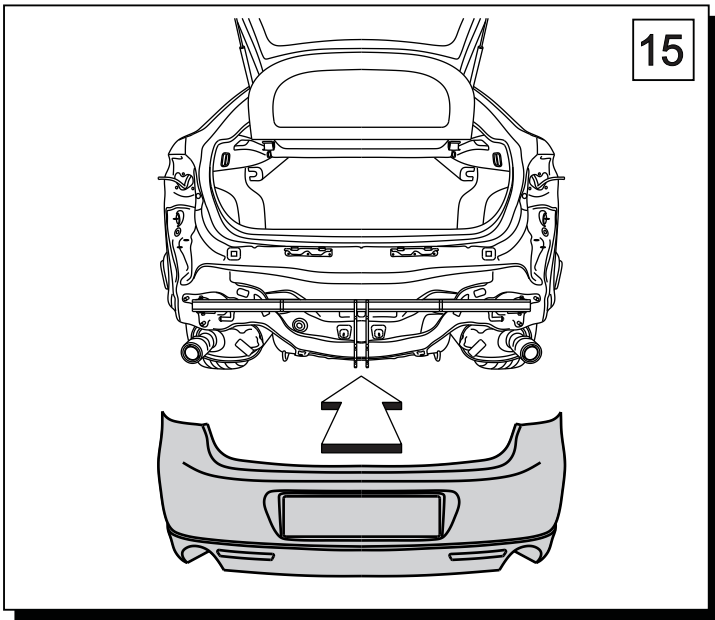

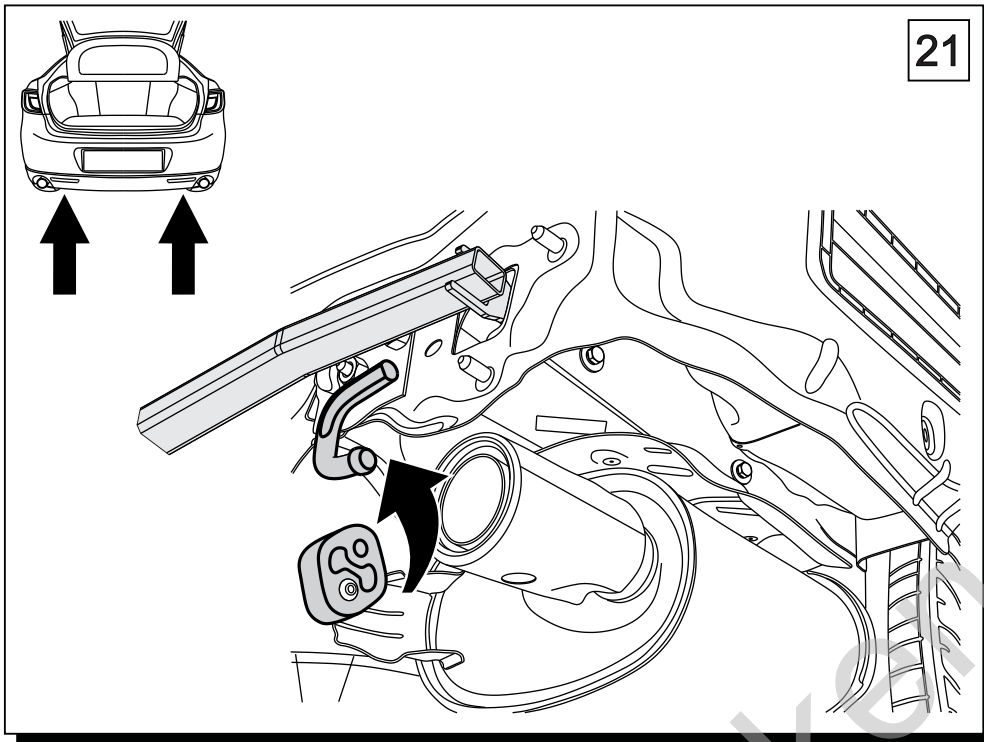



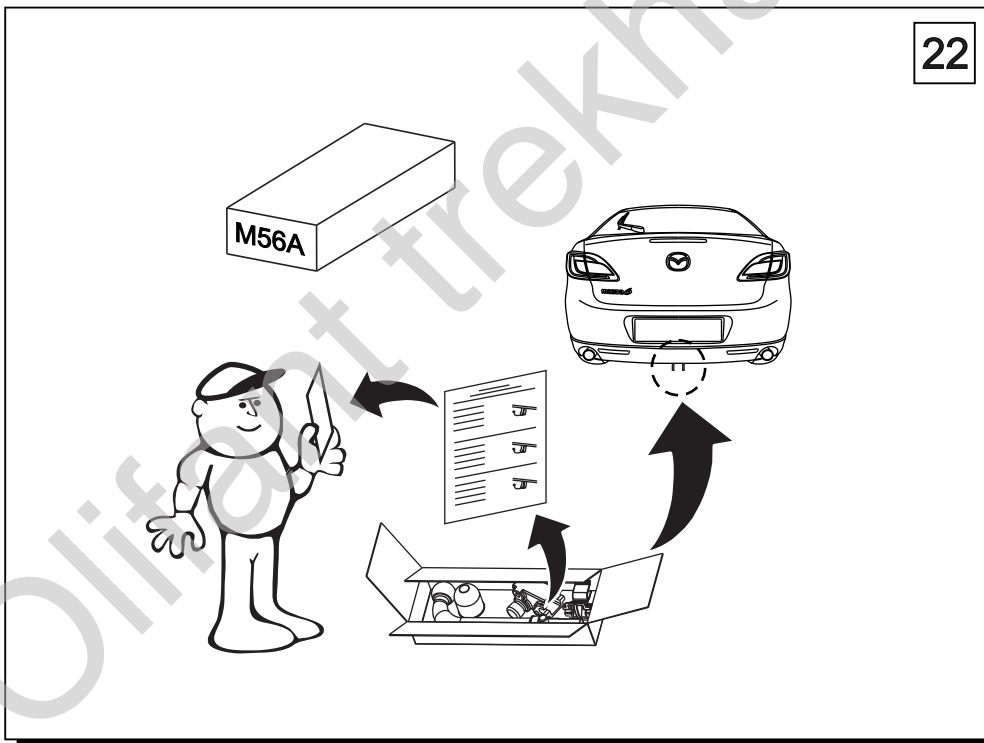

21



22

	M6	-	11 Nm	M8	-	25 Nm
	M10	-	50 Nm	M12	-	87 Nm
	M14	-	138 Nm	M16	-	210 Nm
	 0 km →  1000 km					