

FITTING INSTRUCTION

Clamp mark in acc. with		Cables joining
ISO	PN	
1	L	Left directional lights
2	+	Rear fog lights
3	31	Ground
4	R	Right directional lights
5	58R	Right side parking lights
6	54	Stoplights
7	58L	Left side parking lights

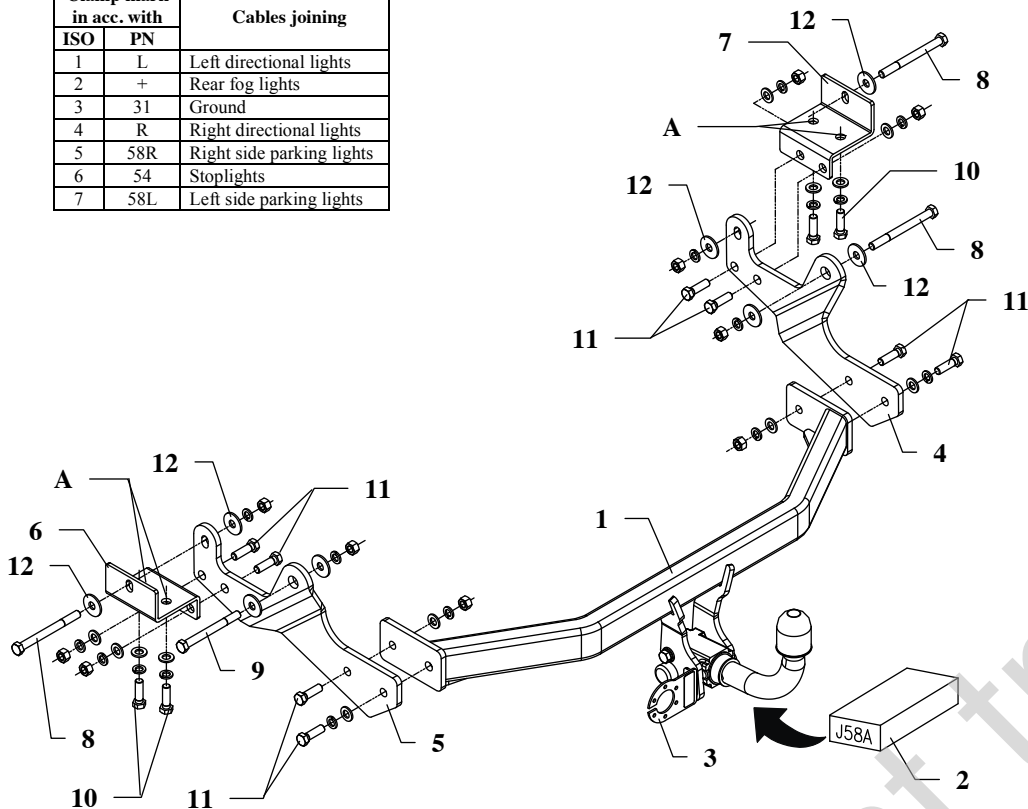

This towing hitch is designed to assembly in following car: **HYUNDAI H1/H300, H1 STAREX, VAN and MINIBUS**, produced since 02.2008, catalogue number **J58A** and is prepared to tow trailers max total weight **2300 kg** and max vertical mass **100 kg**.

From manufacturer

Thank you for buying our product. Their reliability has been confirmed in many tests. Reliability of towing hitch depends also on correct assembly and right operation. For this reasons we kindly ask to read carefully this instruction and apply to hints.

The towing hitch should be install in points described by a car producer.

The instruction of the assembly

1. Take out a spare wheel.
2. Underneath the car find original made holes in the frame of chassis (pos. A). Through this holes fix loosely angle bars (pos. 6 and 7) using bolts M12x1,25x40mm (pos. 10) as shown in the drawing.
3. Put side brackets (pos. 4 and 5) to interior side of the frame of chassis and fix it loosely using bolts M12x130mm (pos. 8) and M12x120mm (pos. 9) as shown in the drawing.
4. Cut out a fragment of central handle fastening a bumper together with metal handle (cut out 5mm), see figure 2.
5. Between installed elements put main bar of the towbar (pos. 1) and fix using bolts M12x40mm (pos. 11) as shown in the drawing.
6. Fix body of the automat (pos. 10) and the socket plate (pos. 3) using bolts M12x25mm (pos. 11) from accessories. Place tow-ball (pos. 2) according to supplied instruction.
7. Tighten all bolts according to the torque shown in the table.
8. Connect electric wires of 7-poles socket according to the instruction of the car. (Recommend to make at authorized service station).
9. Complete paint layer damaged during installation.

Fig. 2.

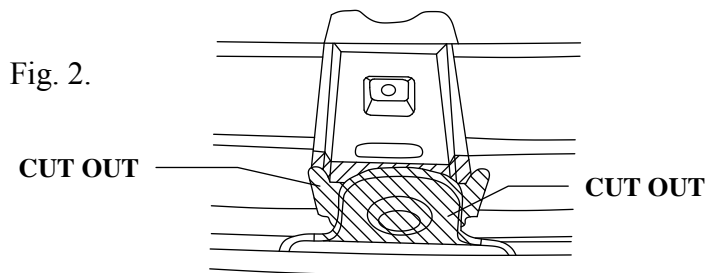

Torque settings for nuts and bolts (8,8):	
M 8 - 25 Nm	M 10 - 55 Nm
M 12 - 85 Nm	M 14 - 135 Nm









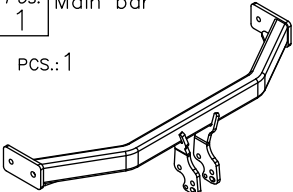
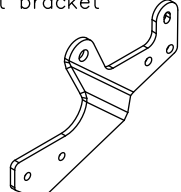

NOTE

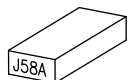
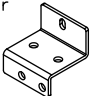
After install the towing hitch you should get adequate note in registration book (at authorised service station). The car should be equipped with:

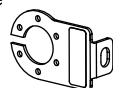
- Indicators
- Tow mirrors

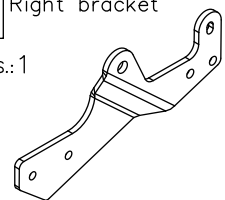
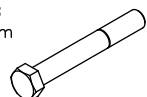
After 1000km of exploitation check all bolts and nuts. The ball of towing hitch must be always kept clear and conserve with a grease.

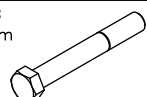
Towing hitch accessories:

Pos. 1 Main bar PCS.: 1	Pos. 5 Left bracket PCS.: 1	Pos. 10 Bolt 8,8 B M12x1,25x40mm PCS.: 4
		
		Pos. 11 Bolt 8,8 B M12x40mm PCS.: 8
		
Pos. 2 Tow ball PCS.: 1	Pos. 6 Left angle bar PCS.: 1	Pos. 12 Plain washer ø37xø13x3mm PCS.: 8
		
Pos. 3 Socket plate PCS.: 1	Pos. 7 Right angle bar PCS.: 1	Pos. 13 Plain washer ø13mm PCS.: 12
		
Pos. 4 Right bracket PCS.: 1	Pos. 8 Bolt 8,8 B M12x130mm PCS.: 3	Pos. 14 Spring washer ø12,2mm PCS.: 16
		
	Pos. 9 Bolt 8,8 B M12x120mm PCS.: 1	Pos. 15 Nut 8 B M12 PCS.: 10
		



PPUH AUTO-HAK S.J.

Produkcja Zaczepów Kulowych
Henryk i Zbigniew Nejman
76-200 SŁUPSK ul. Słoneczna 16K
tel/fax (059) 8-414-414; 8-414-413
E-mail: office@autohak.com.pl
www.autohak.com.pl

Towing hitch (without electrical set)

Class: **A50-X** Cat. no. **J58A**

Designed for:

Manufacturer: **HYUNDAI**

Model: **H1 / H300, H1 STAREX**

Type: **VAN and MINIBUS**

produced since 02.2008

Technical data:

D-value: 13,51 kN

maximum trailer weight: **2300 kg**

maximum vertical cup mass: **100 kg**

Approval number according to Directive 94/20/EC: **e20*94/20*0710*00**

Foreword

This towing hitch is designed according to rules of safety traffic regulations. The towing hitch is a safety component and can be install only by qualified personnel. Any alteration or conversion of the towing hitch is prohibited and would lead to cancellation of design certification. Remove insulating compound and underseal from vehicle (if present) in the area of the matting surfaces of the towing hitch. The vehicle manufacturer's specifications regarding trailer mass and max. vertical cup mass are decisive for driving whereat values for the towing hitch cannot be exceeded.

D-value formula:

$$\frac{\text{Max trailer weight [kg]} \times \text{Max vehicle weight [kg]}}{\text{Max trailer weight [kg]} + \text{Max vehicle weight [kg]}} \times \frac{9,81}{1000} = D \text{ [kN]}$$