

# AUTO-HAK Sp. z o.o.

ul. Słoneczna 16K 76-200 SŁUPSK  
POLAND

tel/fax +48 59 8 414 414; +48 59 8 414 413

e-mail: [office@autohak.com.pl](mailto:office@autohak.com.pl)

[www.autohak.com.pl](http://www.autohak.com.pl)



# AUTO-HAK



**FIAT DOBLO WORK UP**  
Pick-up, ~~AdBlue~~

Cat. no:

**R50A**



08.2011 →

e20

e20\*94/20\*1770\*00

D

9,3 kN



2h



R=1500 kg



S=100 kg

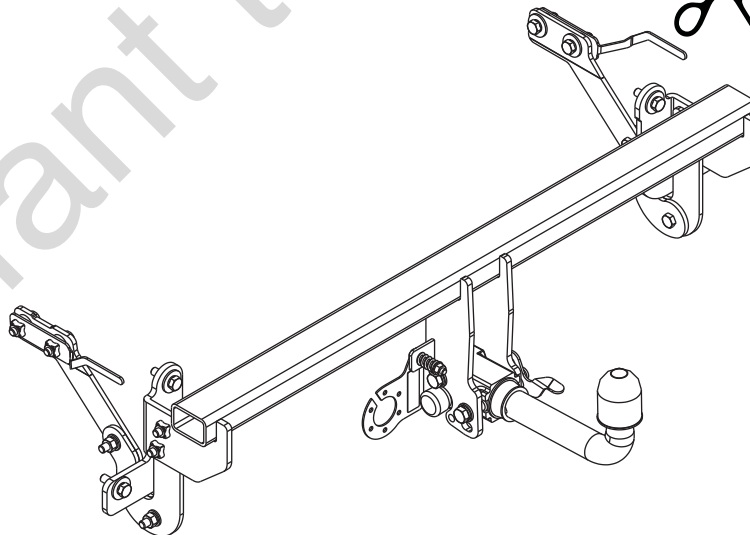

M6 - 11 Nm  
M10 - 50 Nm  
M14 - 138 Nm

M8 - 25 Nm  
M12 - 87 Nm  
M16 - 210 Nm



0 km →



1000 km

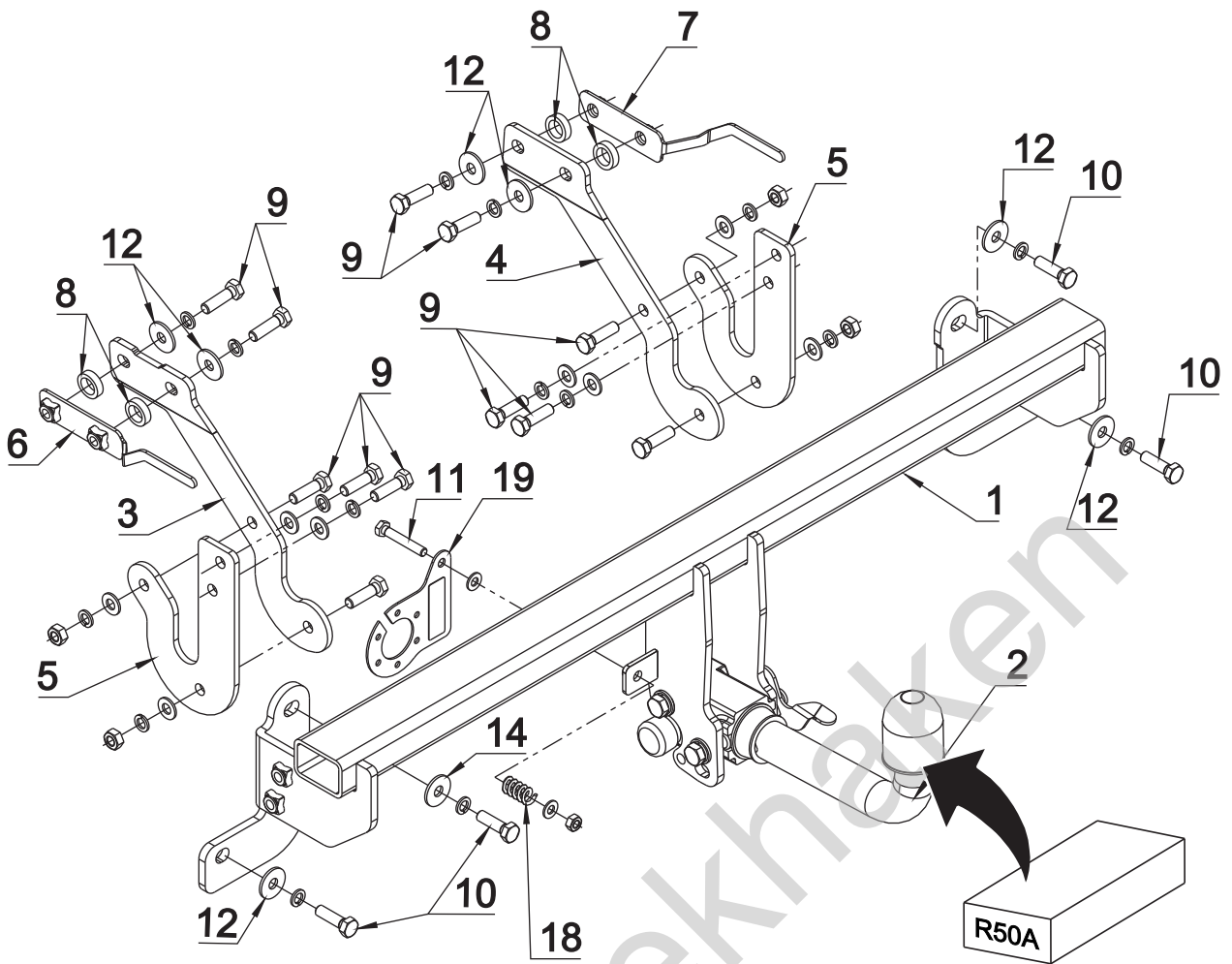

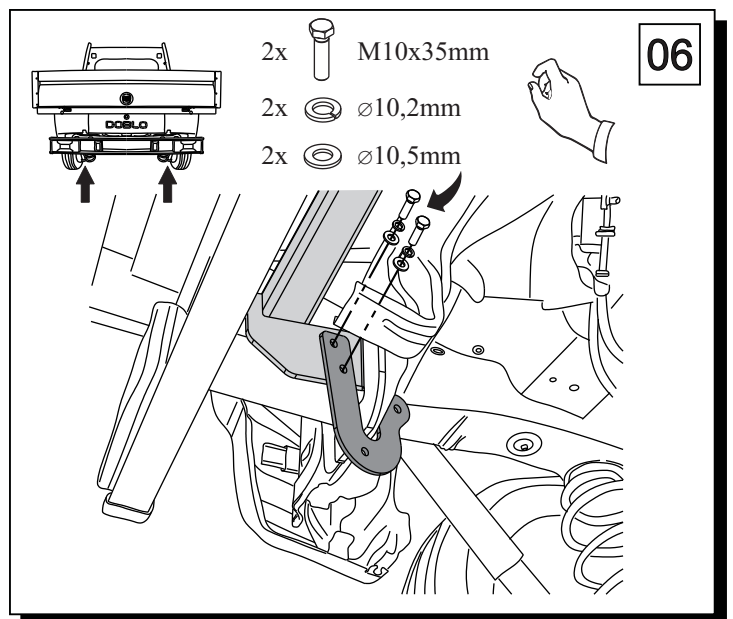
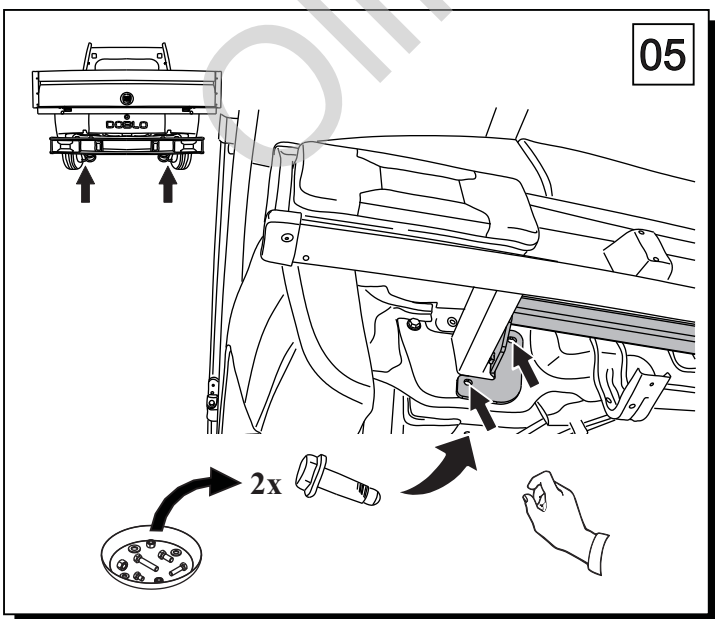
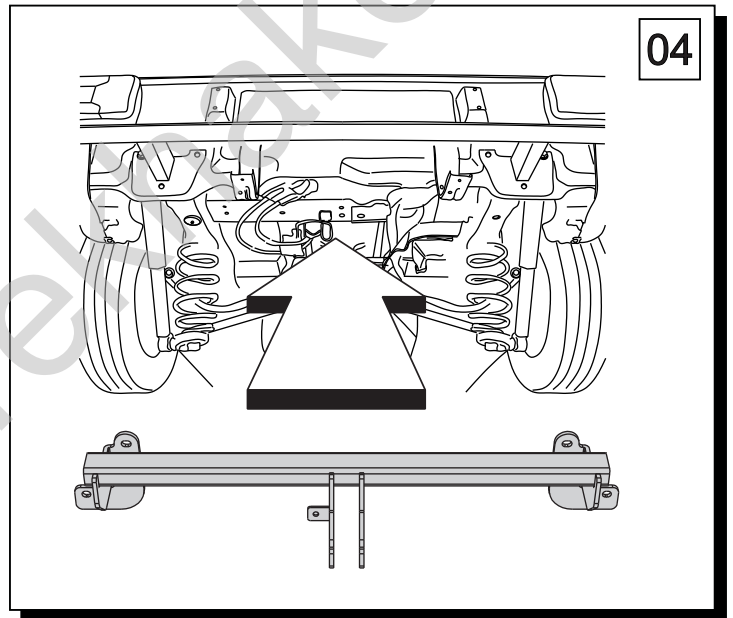
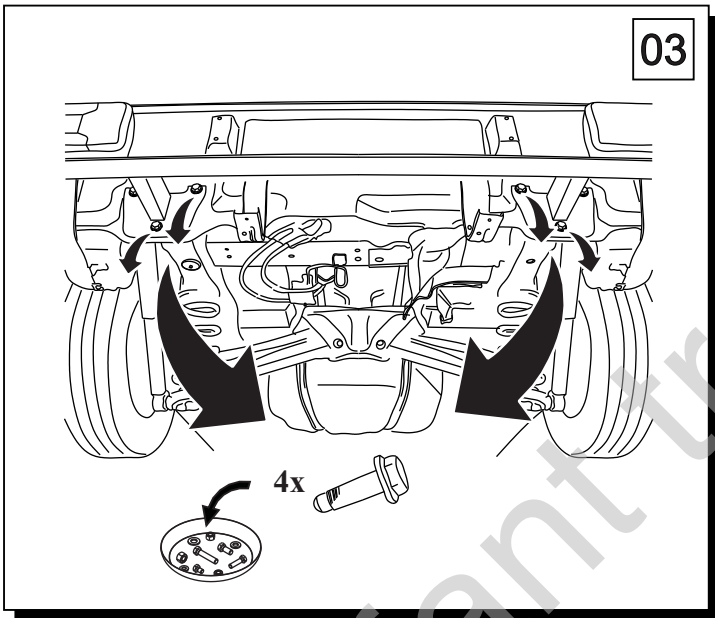
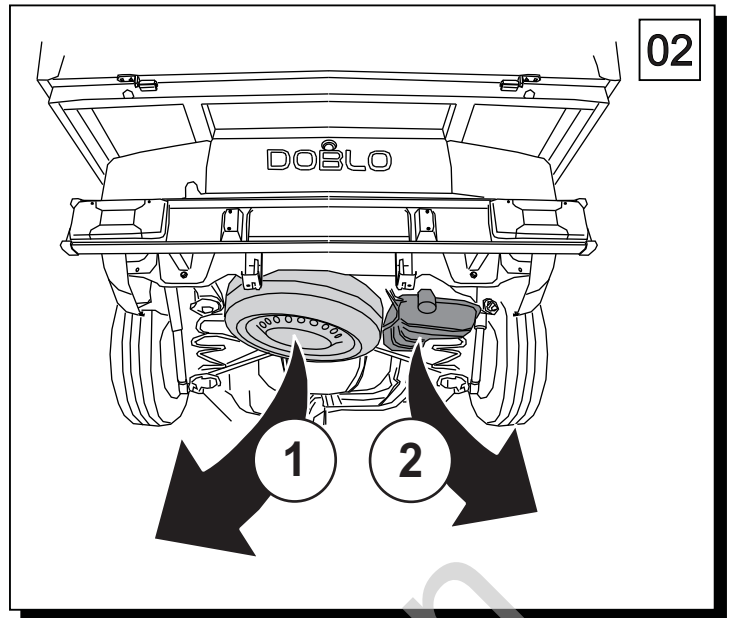
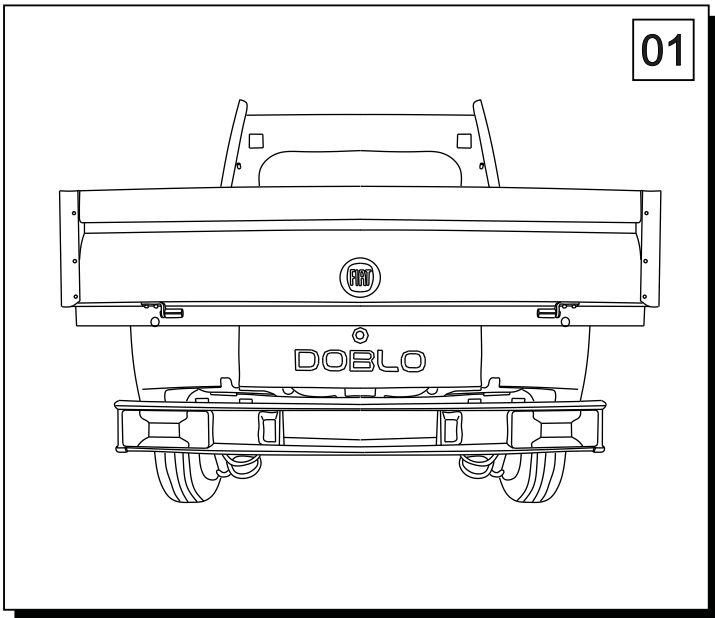

1	x 1		9	M10x35	x 12
2	x 1	 Art.nr-KL1R50A	10	M10x1,25x35	x 4
			11	M8x45	x 1
3	x 1		12	∅ 30x∅10.5x2.5 10 DIN 9021	x8
			13	∅ 10.5	x 8
			14	∅ 8.4	x 2
4	x 1		15	∅ 10.2	x 16
			16	M10	x 4
5	x 2		17	M8	x 1
			18		x 1
6	x 1		19		x 1
7	x 1		Art.nr-BL1R50A		
8	x 4	 ∅25x4mm L=7mm			

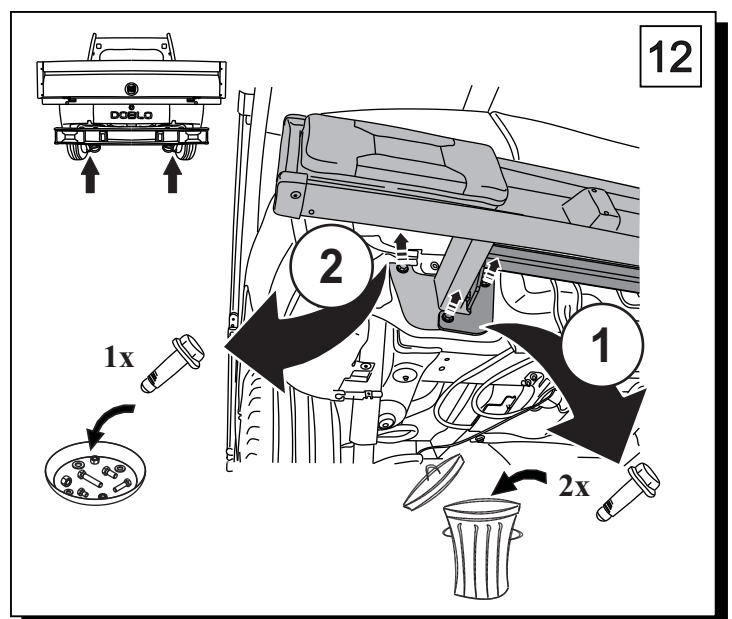
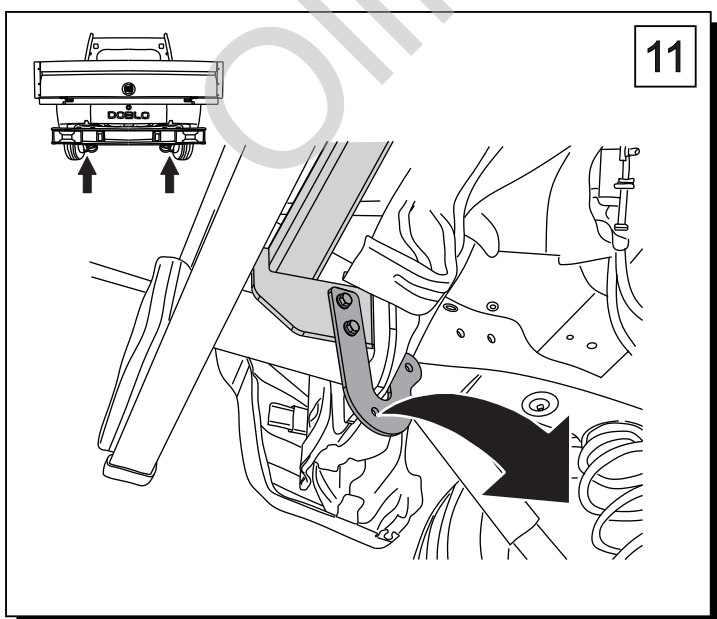
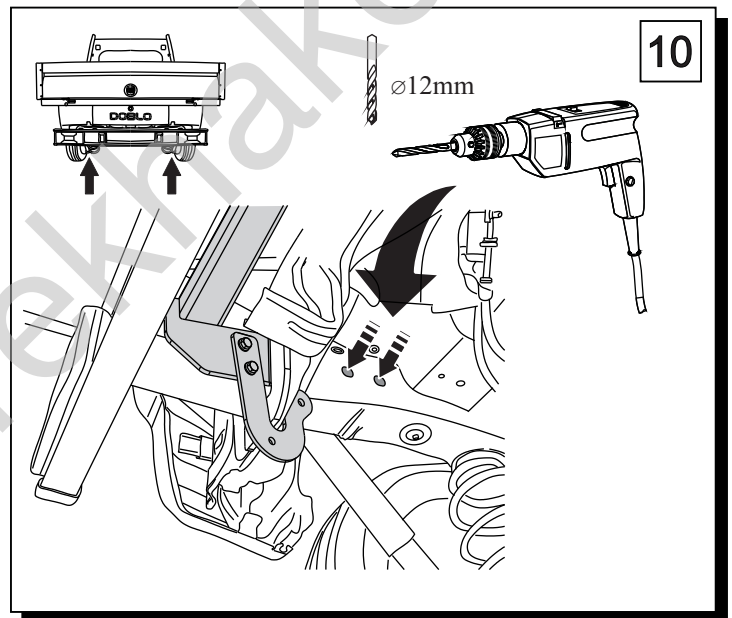
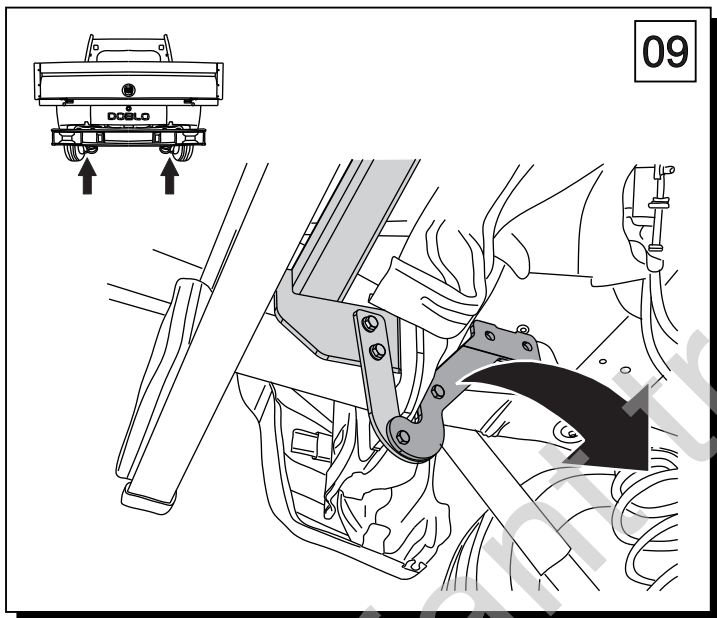
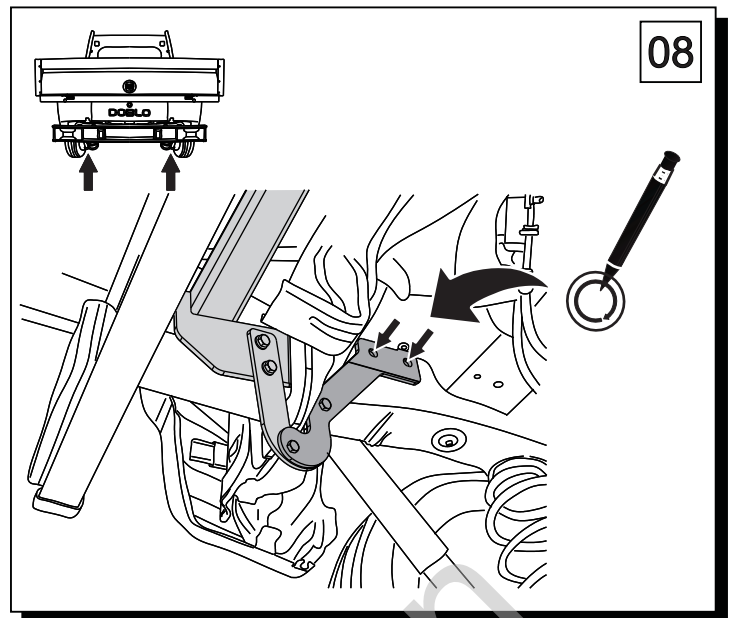
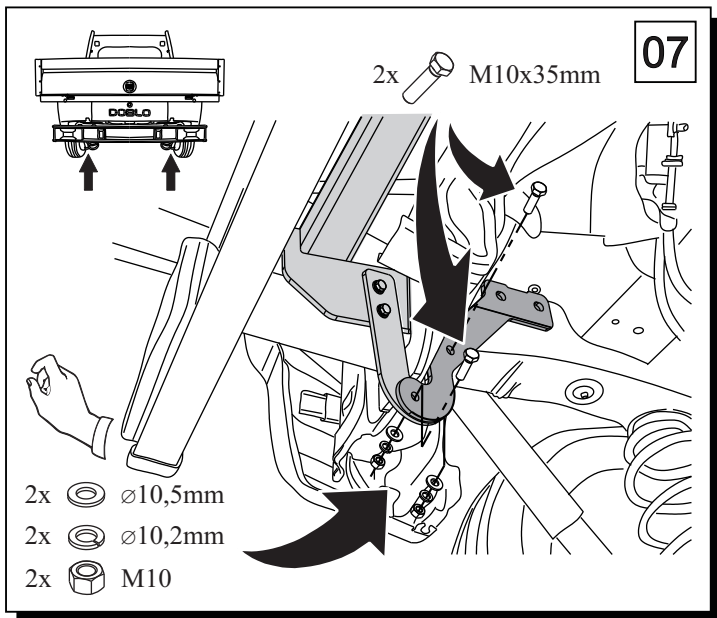

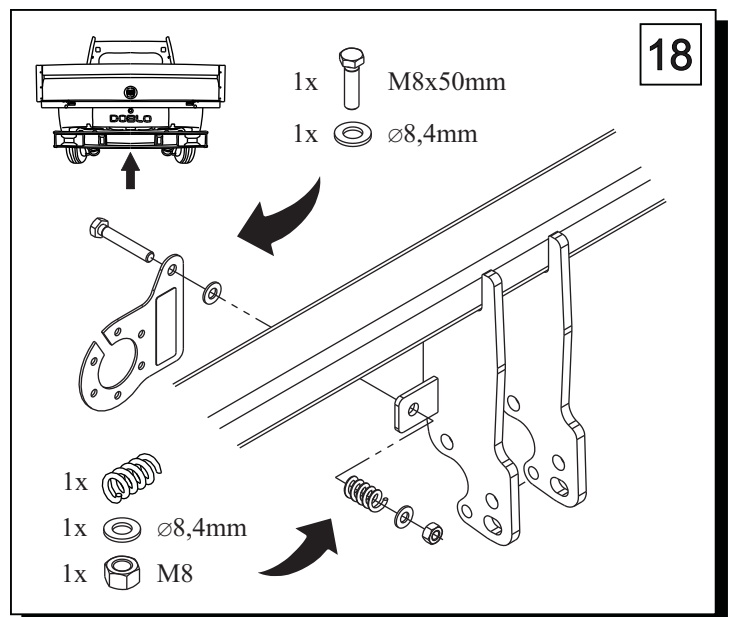
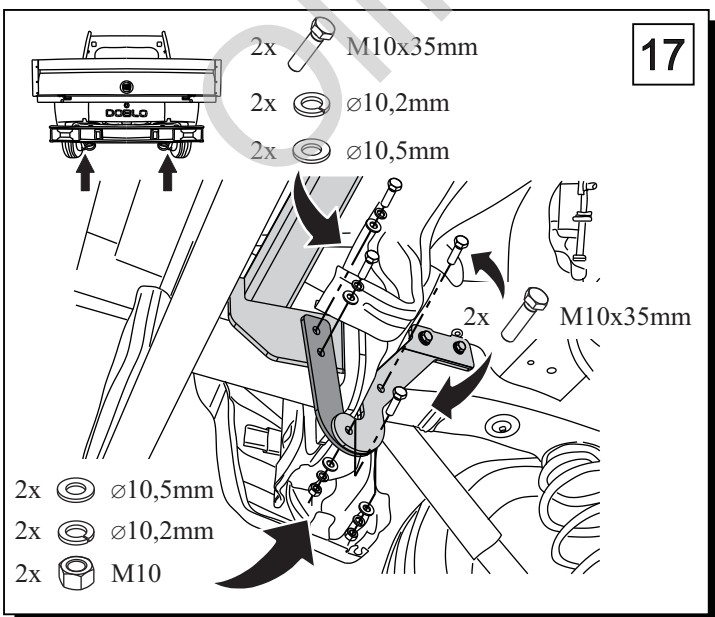
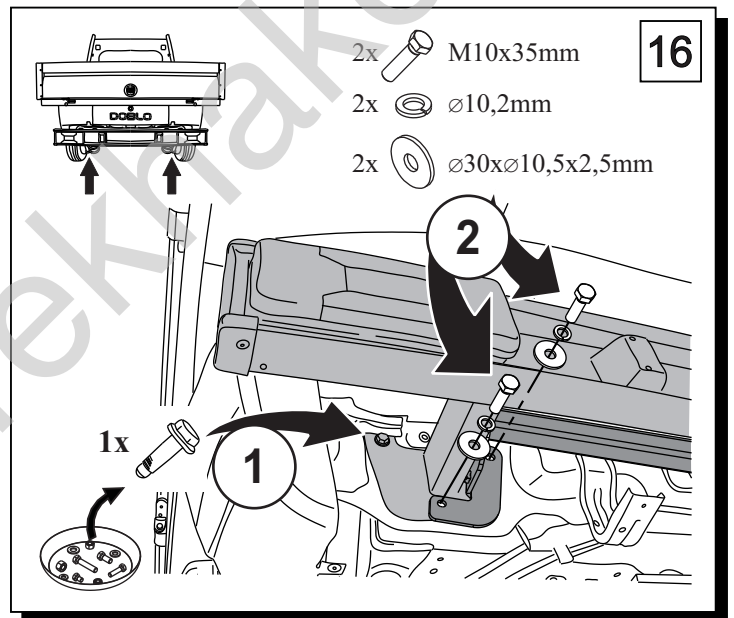
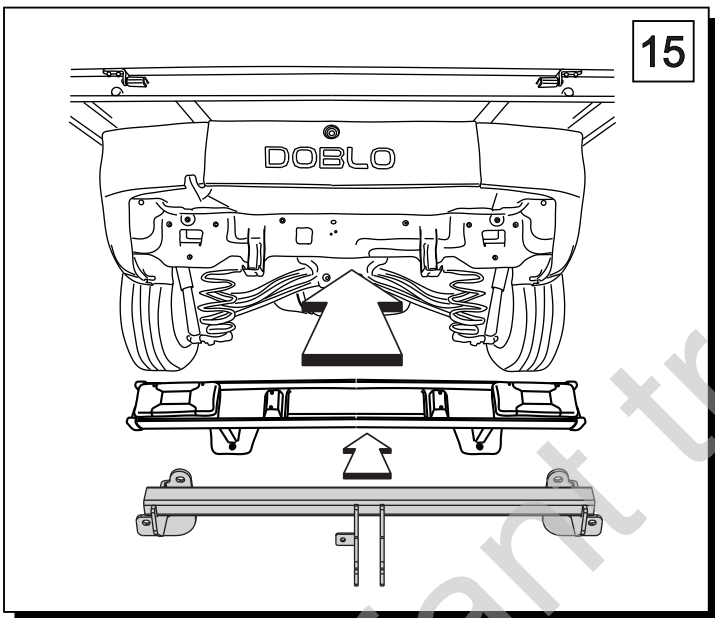
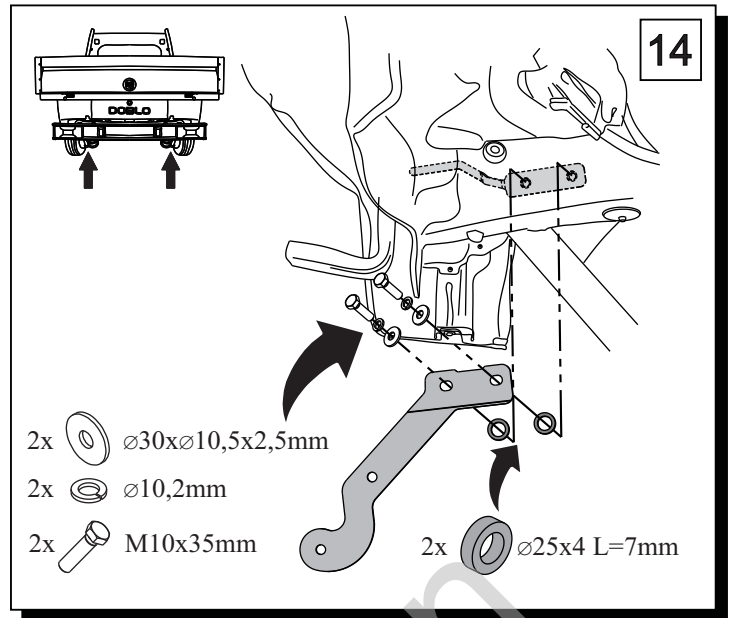
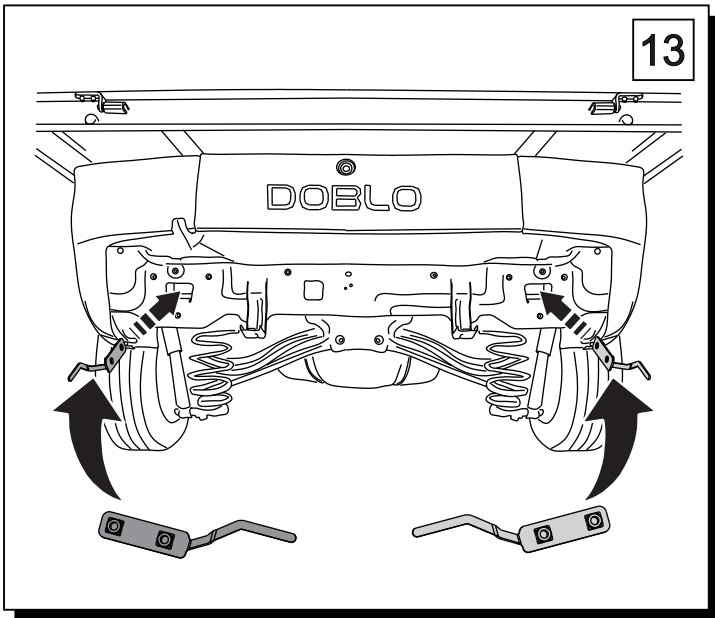

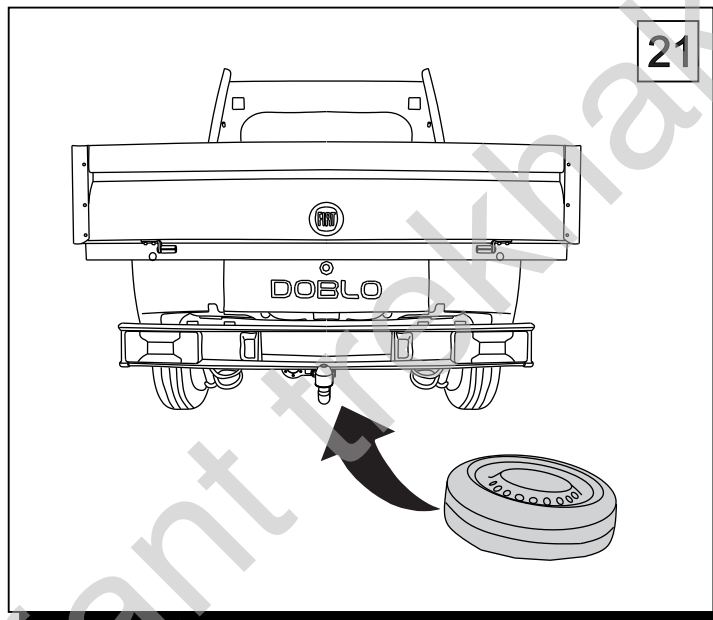
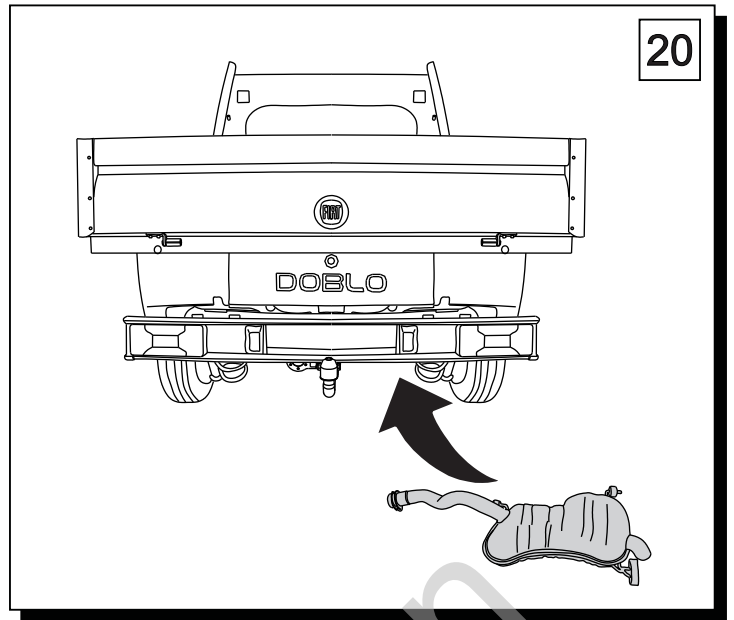
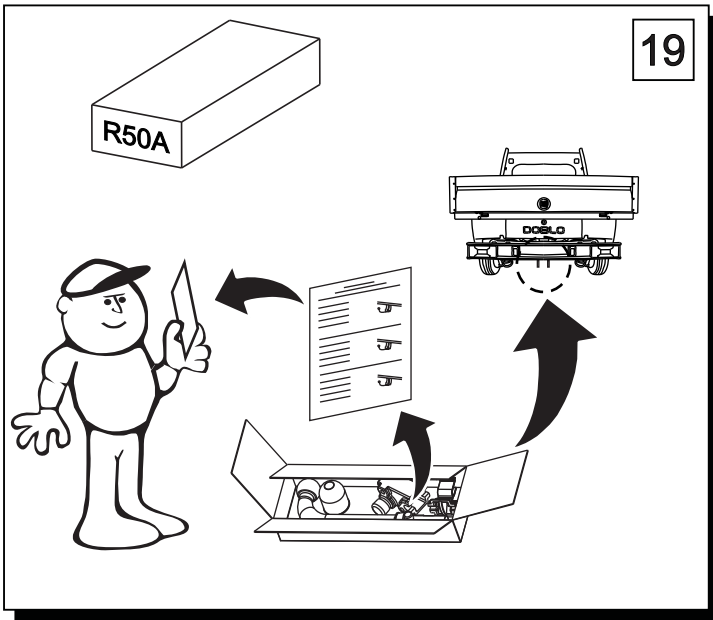





	<b>M6</b> - 11 Nm	<b>M8</b> - 25 Nm
	<b>M10</b> - 50 Nm	<b>M12</b> - 87 Nm
	<b>M14</b> - 138 Nm	<b>M16</b> - 210 Nm

 **0 km** →  **1000 km**