

## FITTING INSTRUCTION

Clamp mark in acc. with		Cables joining
ISO	PN	
1	L	Left directional lights
2	+	Rear fog lights
3	31	Ground
4	R	Right directional lights
5	58R	Right side parking lights
6	54	Stoplights
7	58L	Left side parking lights

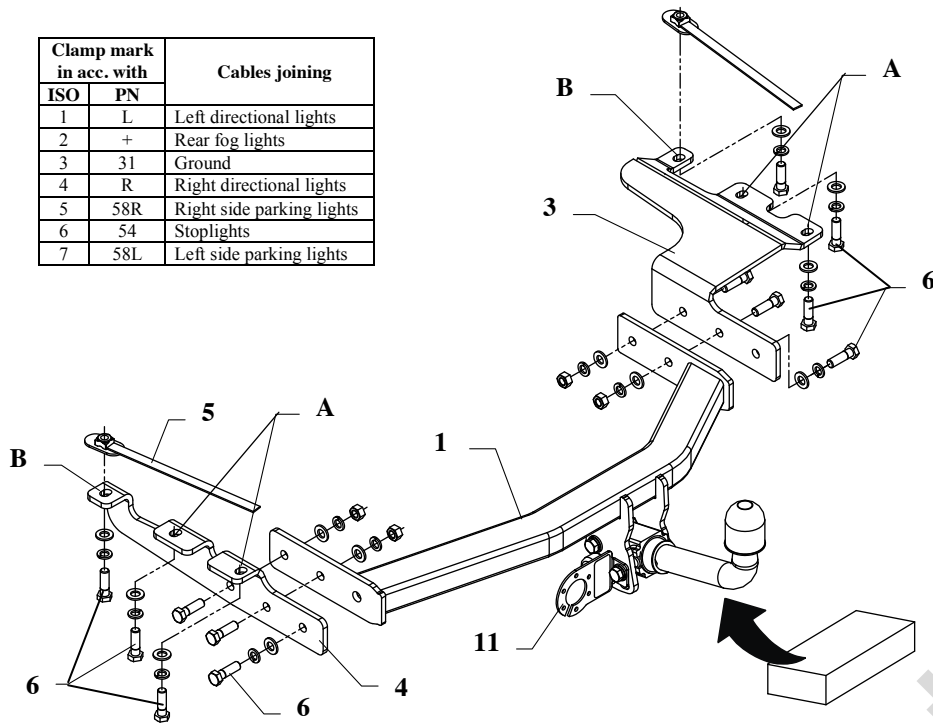

This towbar is designed to assembly in following cars:

**CHRYSLER VOYAGER, GRAND VOYAGER VAN (RG), 4WD** produced since 04.2001 till 02.2008, **DODGE CARAVAN, GRAND CARAVAN VAN, 4WD** produced since 04.2001 till 03.2008, catalogue no. **CH45**, and is prepared to tow trailers max total weight **1600 kg** and max vertical load **80 kg**.

### The instruction of the assembly

- 1) Disassemble original tow eye from left chassis member (not used any more).
- 2) Cut out fragment of the bumper in his bottom part, in axis – see fig. 2).
- 3) To left chassis member fix loosely element pos. 4 through holes A using bolts M12x40mm (pos. 6), next through technological hole put

nut with handle in that way so nut tally with hole B and next fix using bolt M12x40mm (pos. 6).

- 4) To right chassis member fixw element pos. 3 (fix as element pos. 4).
- 5) Between installed elements put main bar of the towbar pos. 1 and fix all using bolts M12x40mm (pos. 6).

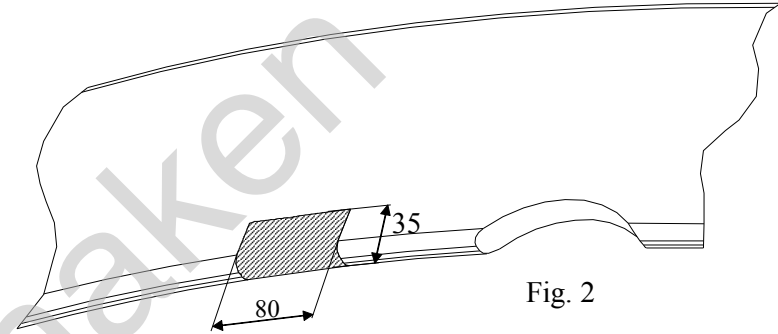

- 6) Fix body of the automat and the socket plate (pos. 3) using bolts M12 from accessories. Place tow-ball according to supplied instruction.
- 7) Tighten all bolts according to the torque shown in the table.
- 8) Connect electric wires of 7-poles socket according to the instruction of the car. (Recommend to make at authorized service station)
- 9) Complete paint layer damaged during installation.

Torque settings for nuts and bolts (8,8):

<b>M 8</b>	25 Nm	<b>M 10</b>	55 Nm
<b>M 12</b>	85 Nm	<b>M 14</b>	135 Nm







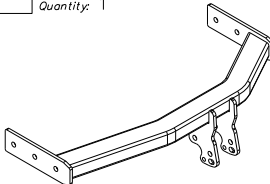
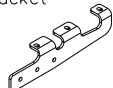

### NOTE

After install the towbar you should get adequate note in registration book (at authorised service station).The car should be equipped with:

- Indicators
- Tow mirrors

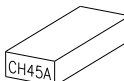
After 1000km of exploitation check all bolts and nuts. The ball of towbar must be always kept clear and conserve with a grease.

## Towbar accessories:

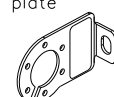
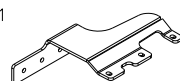
Pos. 1	Name: Main bar Quantity: 1	Pos. 4	Name: Left bracket Quantity: 1	Pos. 8	Name: Plain washer Quantity: 12 Dim. : $\varnothing$ 13 mm
					
		Pos. 5	Name: Nut on the jib Quantity: 2	Pos. 9	Name: Spring washer Quantity: 12 Dim. : $\varnothing$ 12,2 mm
					
Pos. 2	Name: Tow ball Quantity: 1	Pos. 6	Name: Bolt 8,8 B Quantity: 12 Dim. : M12x40mm	Pos. 10	Name: Ball cover Quantity: 1
					
		Pos. 7	Name: Nut 8 B Quantity: 4 Dim. : M12	Pos. 11	Name: Socket plate Quantity: 1
					
Pos. 3	Name: Right bracket Quantity: 1				
					



**PPUH AUTO-HAK Sp.J.**

Produkcja Zaczepów Kulowych  
Henryk i Zbigniew Nejman  
76-200 SŁUPSK ul. Słoneczna 16K  
tel/fax (059) 8-414-414; 8-414-413  
E-mail: [office@autohak.com.pl](mailto:office@autohak.com.pl)  
[www.autohak.com.pl](http://www.autohak.com.pl)

## Towing hitch (without electrical set)

Class: **A50-X** Cat. no. **CH45A**

Designed for:

Manufacturer: **CHRYSLER**

Model: **VOYAGER** and  
**GRAND VOYAGER VAN (RG), 4WD**

produced since 04.2001 till 02.2008

Manufacturer: **DODGE**

Model: **CARAVAN, GRAND CARAVAN VAN, 4WD**

produced since 04.2001 till 03.2008

Technical data:

**D-value: 9,75 kN**

maximum trailer weight: **1600 kg**

maximum vertical cup load: **80 kg**

Approval number according to Directive 94/20/EC: **e20\*94/20\*0794\*00**

## Foreword

This towbar is designed according to rules of safety traffic regulations. The towing hitch is a safety component and can be install only by qualified personnel. Any alteration or conversion of the towing hitch is prohibited and would lead to cancellation of design certification. Remove insulating compound and underseal from vehicle (if present) in the area of the matting surfaces of the towing hitch.

The vehicle manufacturer's specifications regarding trailer load and max. vertical cup load are decisive for driving whereat values for the towing hitch cannot be exceeded.

*D-value formula:*

$$\frac{\text{Max trailer weight [kg]} \times \text{Max vehicle weight [kg]}}{\text{Max trailer weight [kg]} + \text{Max vehicle weight [kg]}} \times \frac{9,81}{1000} = D \text{ [kN]}$$